



INSTALLATION INSTRUCTIONS FOR PART 99-7515

APPLICATIONS

Mazda RX-8

2009-2010

99-7515B/ 99-7515HG

KIT FEATURES

- DIN Head Unit Provision with Pocket
- ISO DIN Head Unit Provision with Pocket
- DDIN Head Unit Provision
- ISO Stacked Head Unit Provision
- Painted to Match Factory Finishes
- TWO FINISHES AVAILABLE:
99-7515B=BLACK, 99-7515HG=GLOSS BLACK



KIT COMPONENTS

- A) Radio Housing • B) ISO Brackets • C) ISO Trim Plate • D) DDIN Brackets
- E) DDIN Trim Plate • F) Pocket • G) (5) Plastic Snaps

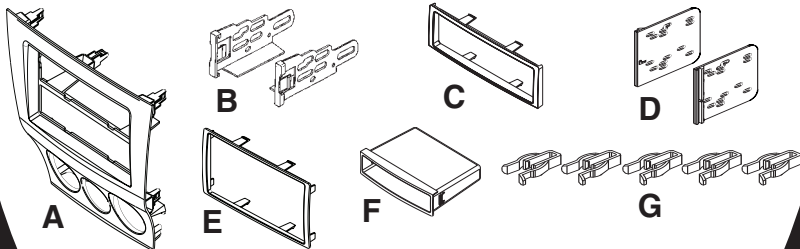

WIRING AND ANTENNA CONNECTIONS (Sold Separately)

- 70-7903 - 2001-up Mazda harness

TOOLS REQUIRED:

- Small Flat Blade Screwdriver • Panel Removal Tool
- Phillips Screwdriver • Socket Set • Cutting Tool

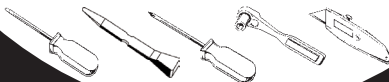

1-800-221-0932



www.metraonline.com

© COPYRIGHT 2004-2008 METRA ELECTRONICS CORPORATION

TABLE OF CONTENTS

Dash Disassembly

- Mazda RX-8 2009-20101,2

Kit Preparation3

Kit Assembly

- DIN Head Unit Provision with Pocket 4

- ISO DIN Head Unit Provision with Pocket 5

- Double DIN / Stacked ISO DIN Head Unit Provision 6

***Note:**

Refer also to the instructions included with the aftermarket radio.



KNOWLEDGE IS POWER

Enhance your installation and fabrication skills by enrolling in the most recognized and respected mobile electronics school in our industry. Log onto www.installerinstitute.com or call 800-354-6782 for more information and take steps toward a better tomorrow.



Metra recommends MECP certified technicians.

MAZDA RX-8 2009-2010

- 1** Disconnect the negative battery terminal to prevent an accidental short circuit.
- 2** Unscrew the shift knob counter clockwise to remove. (Figure A)
- 3** Unclip and remove the shifter trim panel. (Figure B)
- 4** Remove (2) Phillips screws from the bottom of the ashtray assembly then unclip and remove the assembly. (Figure C)
- 5** Remove (2) Phillips screws from the bottom of the radio/climate control panel. (Figure D)
- 6** Unclip and remove the knee panel on the driver's side under the steering column (Figure E) then remove (1) 10 MM bolt from the side of the radio bracket. (Figure F)

Continued on page 2.

A

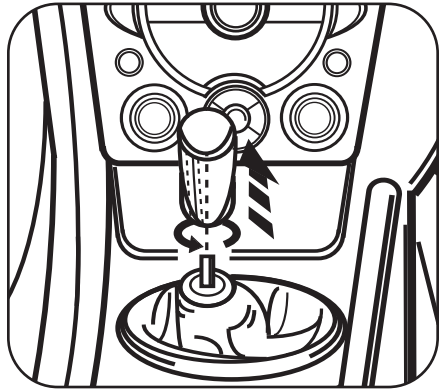

B

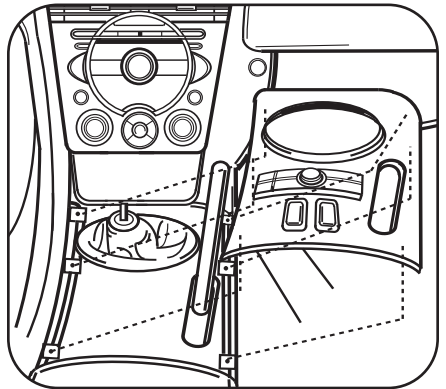

D

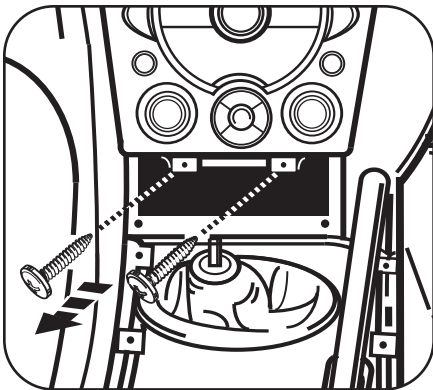

C

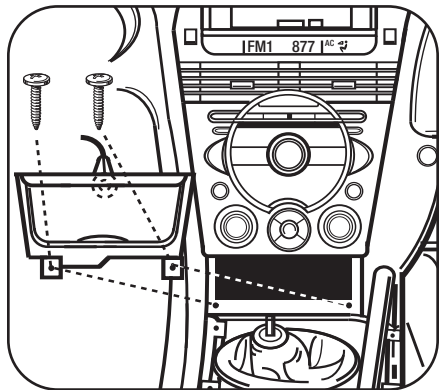

MAZDA RX-8 2009-2010

- 7** Unsnap and remove the radio/climate control panel including radio chassis.
- 8** Remove climate controls from radio/climate control panel.

Continue to kit preparation.

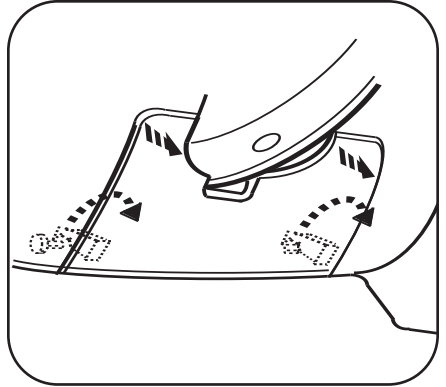
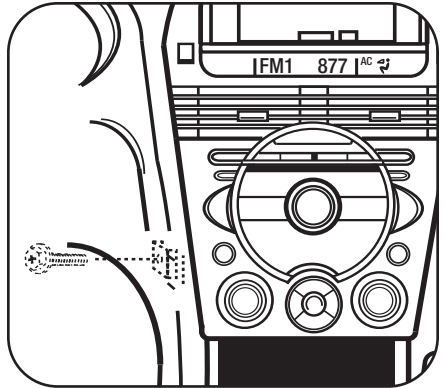
E

F

MAZDA RX-8 2009-2010

****Note: Refer also to the instructions included with the aftermarket radio.***

1 Mount the climate controls to the Radio Housing using the factory hardware.
(Figure A)

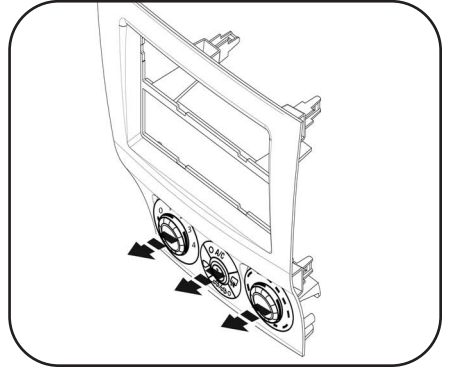
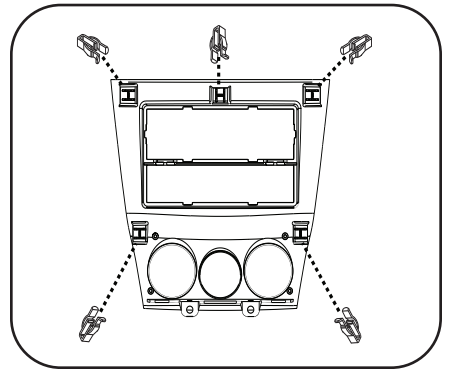
2 Slide the five plastic clips provided in this kit to the legs located on the back of the radio housing.. (Figure B)

A

B

DIN HEAD UNIT PROVISION WITH POCKET

**Note: Refer also to the instructions included with the aftermarket radio.*

- 1** Locate the factory wiring harness in the dash. Metra recommends using the proper mating adapter from Metra or AXCESS. Re-Connect the negative battery terminal and test the unit for proper operation.
- 2** Slide the DIN cage into the Radio Housing and secure by bending the metal locking tabs outward. (Figure A)
- 3** Snap the pocket into the bottom opening of the radio housing. (Figure B)
- 4** Slide the aftermarket head unit into the cage and secure. (Figure C)
- 5** Reassemble the dash in reverse order of disassembly.

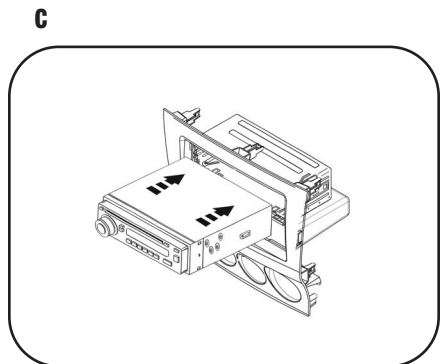
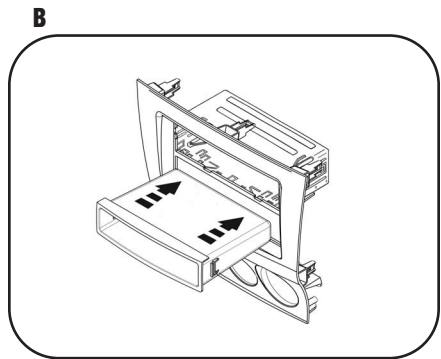
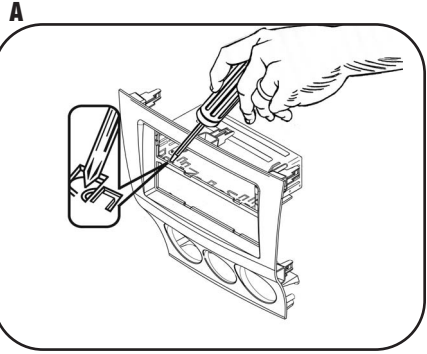
Continue to final assembly.



ISO DIN HEAD UNIT PROVISION WITH POCKET

1 Locate the factory wiring harness in the dash. Metra recommends using the proper mating adapter from Metra or AXXESS. Re-Connect the negative battery terminal and test the unit for proper operation.

2 Mount the ISO Brackets to the radio using the screws supplied with the radio. (Figure A)

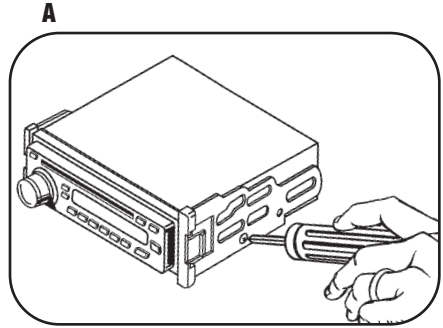

3 Snap the pocket into the bottom opening of the radio housing. (Figure B)

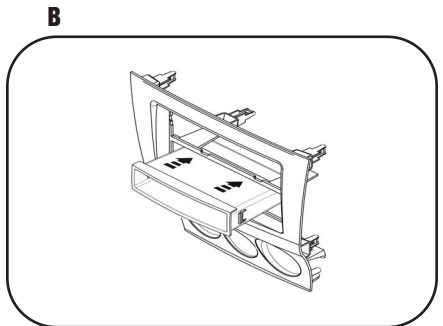

4 Slide the head unit into the radio opening until the side clips engage. (Figure C)

5 Snap the Trim plate into the Radio Housing. (Figure C)

6 Reassemble dash in reverse order of disassembly.

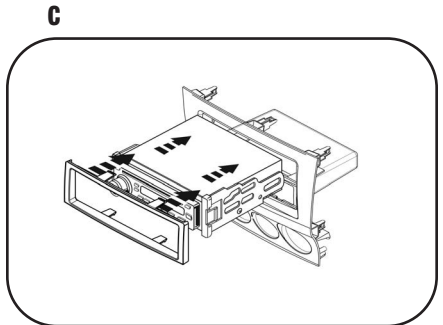

DOUBLE DIN / STACKED ISO DIN HEAD UNIT PROVISION

- 1** Locate the factory wiring harness in the dash. Metra recommends using the proper mating adapter from Metra or AXCESS. Re-Connect the negative battery terminal and test the unit for proper operation.
- 2** Cut and remove the center bar from the radio housing. (Figure A)
- 3** Snap the Double DIN brackets to the inside edge of the Radio Housing. (Figure B)
- 4** Slide the Double DIN head unit or stacked ISO head units into the bracket/radio housing assembly and secure the Double DIN head unit or stacked ISO head units to the assembly using the screws supplied with the radio.
- 5** Snap the double DIN trim plate into the radio housing. (Figure C)
- 6** Reassemble dash in reverse order of disassembly. (Figure C)

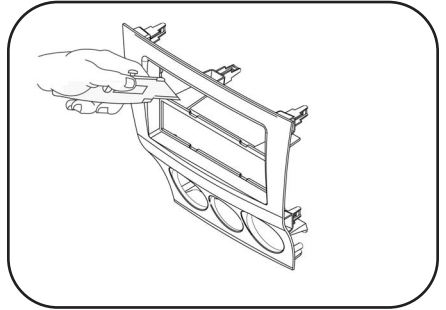
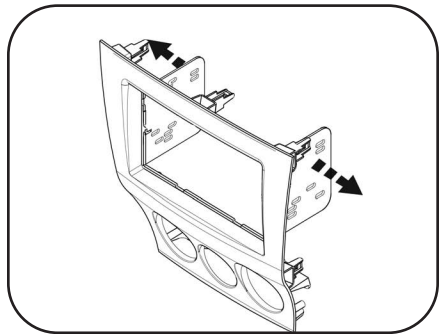
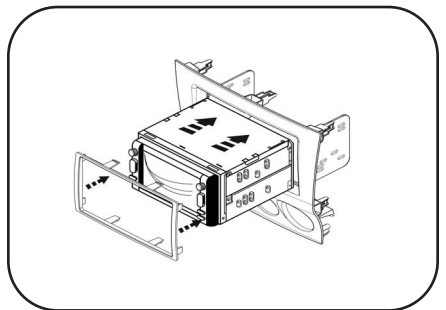
A

B

C

99-7515 INSTRUCTIONS



1-800-221-0932



www.metraonline.com

REV. 11/10/09 © COPYRIGHT 2004-2008 METRA ELECTRONICS CORPORATION INST99-7515