

Procédure de montage d'un système de navigation dans une **Ford Transit Connect 2014 avec afficheur.**



Pièces Pioneer

Kit 2 Din : Noir

réf : CA-HM-FOR.010B

CA-HM-FOR.10S

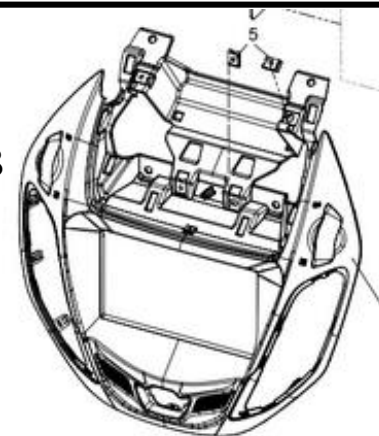

Adaptateur antenne

réf : CA-AE-FOR.001



Interface électrique :

réf : CA-R-FOR .005



Pièce détachée Ford

Réf : 1799698

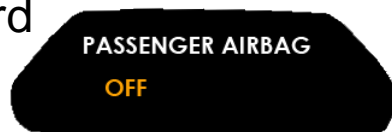

Pioneer
CIP

Mesures de sécurité



Avant toutes intervention sur le véhicule!!!

- Contrôler la tension de courant du véhicule **+/- 12 V**.
- Le pôle **négatif** de la batterie à la **carrosserie**.
- Afin d'éviter tout risque de court-circuit et de réinitialisation du système électrique du véhicule, **débrancher le câble** de la borne négative de la batterie avant de commencer la pose.

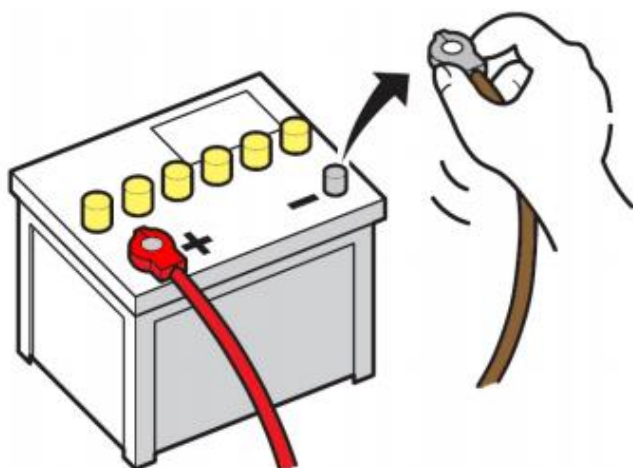

Dépose du système radio d'origine



Dépose du système radio d'origine

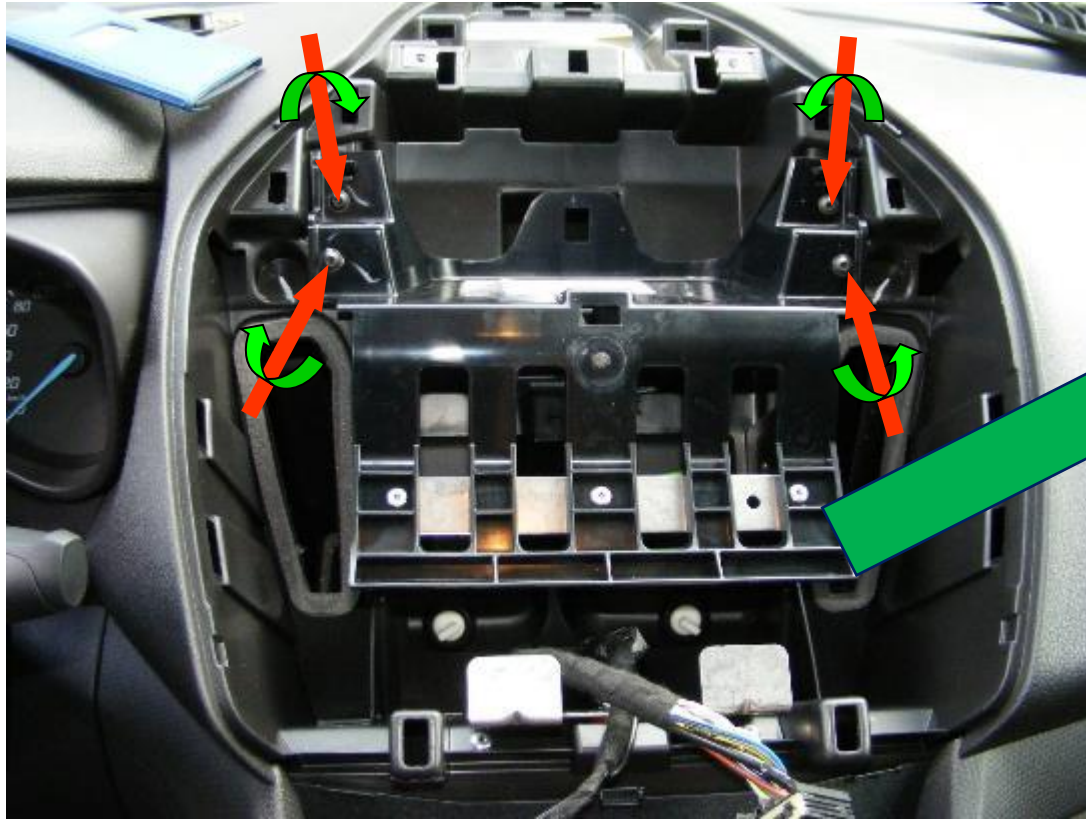

Dépose du système radio d'origine



Pièce détachée
Ford
Réf : 1799698

PASSENGER AIRBAG
OFF

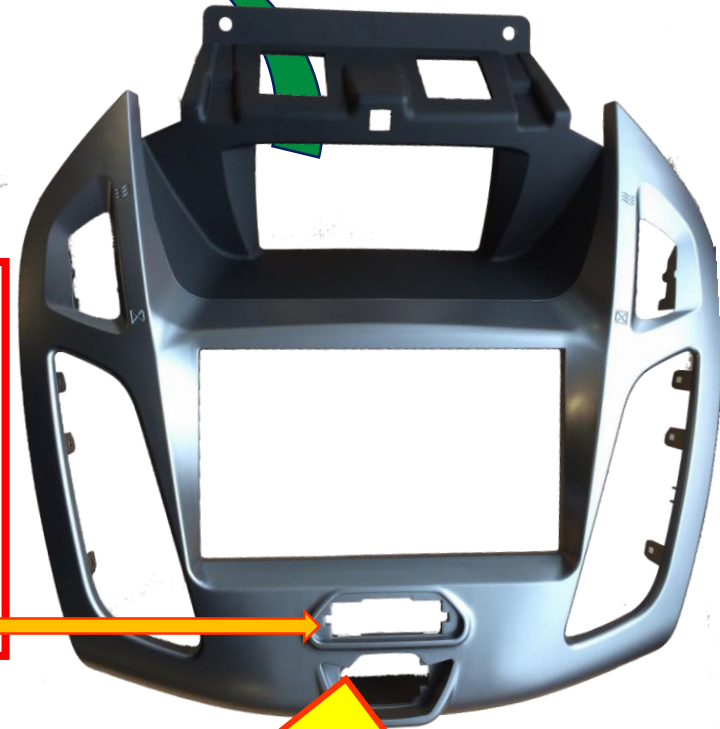

Pioneer
CIP

Préparation de la platine autoradio

Démontage des deux bouches d'air de la platine Ford

Remontage des deux bouches d'air de la platine Ford Pioneer



Installation de l'antenne GPS

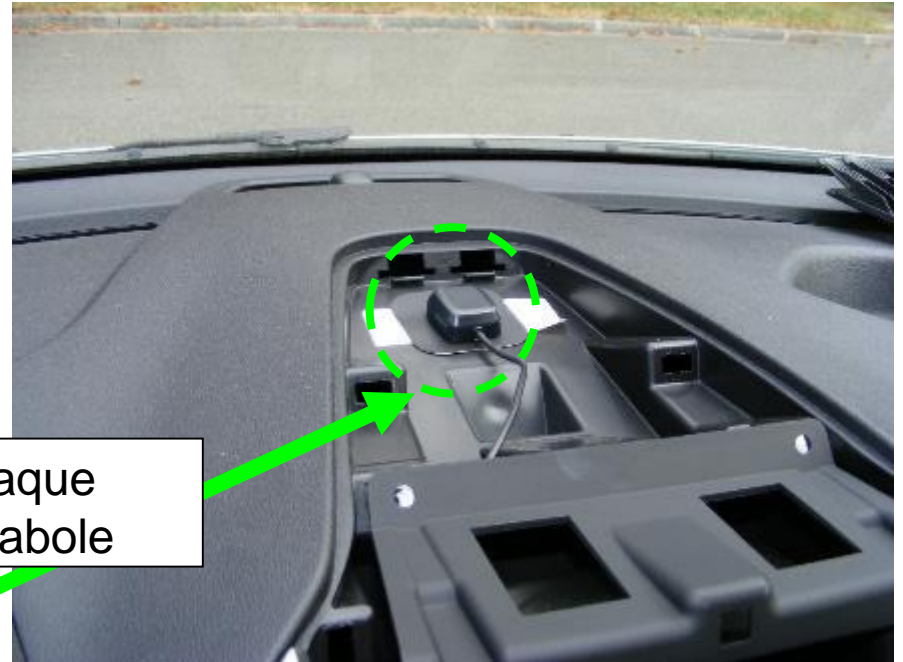

Antenne
Satellite

Plaque
parabole

Haut

BAS

Attention:

Placer toujours l'antenne GPS
vers le haut et la plaque
métallique vers le sol.

Passage et installation du micro



Passage du câble micro



Branchements électriques



Signal de vitesse
Fil Rose de l'adaptateur avec le fil
Rose Pioneer CAR SPEED
SIGNAL INPUT

Signal sécurité
Fil Vert de
l'adaptateur avec le fil
Vert Pioneer
PARKING BRAKE

Signal marche arrière
Fil Violet/blanc de
l'adaptateur avec le fil
Violet/blanc Pioneer
REVERSE-GEAR SIGNAL
INPUT



1. Déconnecter l'afficheur Ford, connecter cette prise sur l'interface.
2. Connecter la prise interface sur l'afficheur Ford.

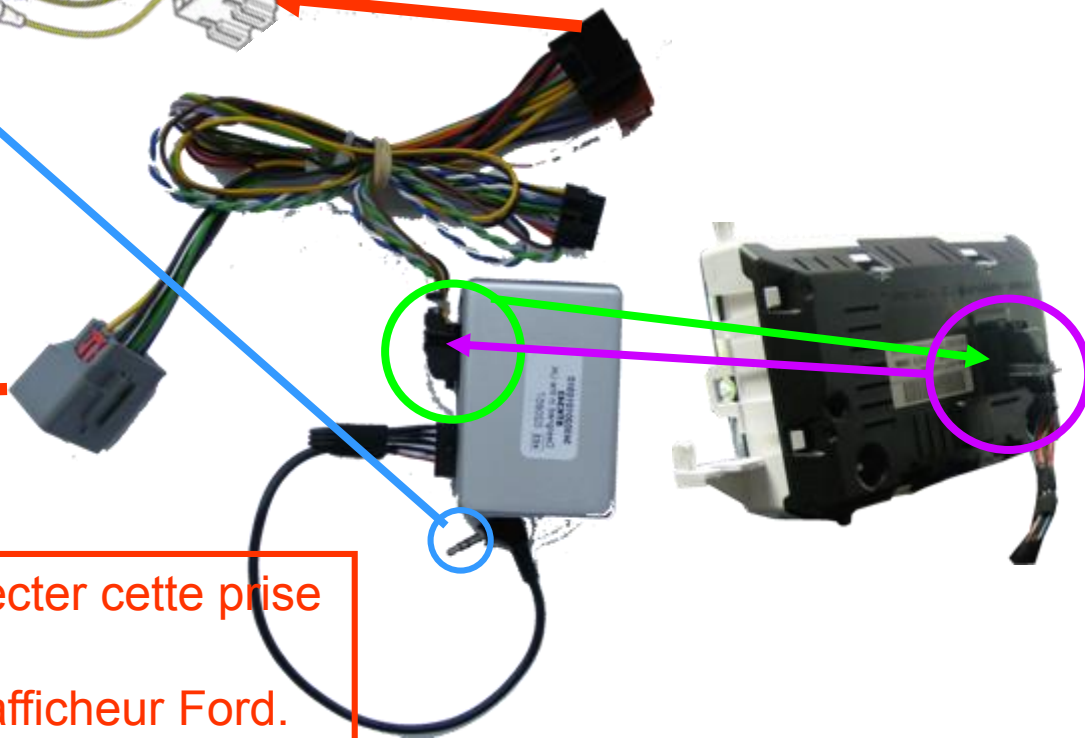

Préparation de la navigation Pioneer

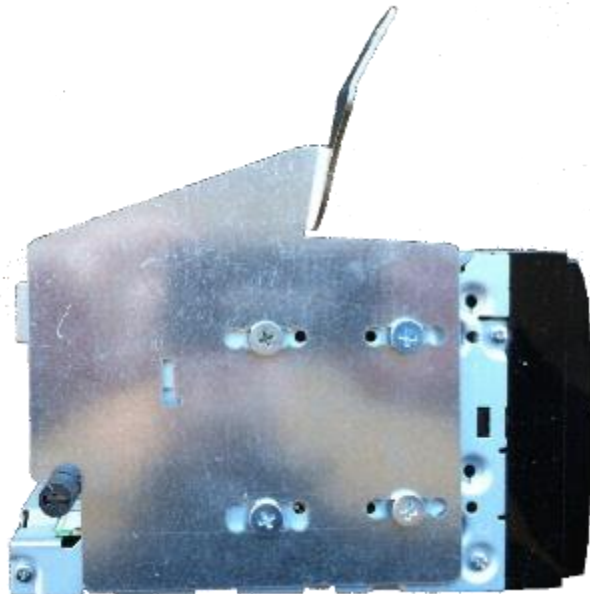

Préparation de la navigation Pioneer

