



## INSTALLATION INSTRUCTIONS FOR PART 95-5812 or 99-5812

### APPLICATIONS

See application list inside

## Ford multi-kit 2004-up 95-5812 or 99-5812

### KIT FEATURES

95-5812:

- Double DIN radio provision

99-5812:

- DIN radio provision with pocket
- ISO radio provision with pocket



### KIT COMPONENTS

- 95-5812: • A1) Radio housing (double DIN & stacked ISO DIN) • B1) Double DIN brackets  
• C1) Spacers • D1) (4) Screws
- 99-5812: • A2) Radio housing • B2) ISO brackets • C2) Trim plate • D2) Side brackets  
• E2) Spacers • F2) (4) Screws

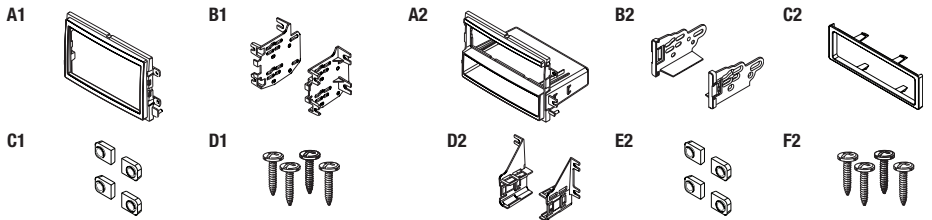

### WIRING & ANTENNA CONNECTIONS (sold separately)

Wiring Harness:

- 70-5520 - Ford harness 2003-up
- 70-5521 - Ford amplified harness 2003-up
- 70-5522 - Ford sub harness 2003-up
- XSVI-5520 - NAV Ford interface 2006-up

Antenna Adapter:

- 40-CR10 - Chrysler/GM antenna adapter 2002-up

### TOOLS REQUIRED

- Panel removal tool • Phillips screwdriver
- Socket wrench

**CAUTION:** Metra recommends disconnecting the negative battery terminal before beginning any installation. All accessories, switches, and especially air bag indicator lights must be plugged in before reconnecting the battery or cycling the ignition.

**NOTE:** Refer to the instructions included with the aftermarket radio.

REV. 2/10/2014 INST-5812

## Applications

### Ford

|                           |           |
|---------------------------|-----------|
| Edge.....                 | 2007-2010 |
| Expedition .....          | 2007-up   |
| Explorer.....             | 2006-2010 |
| Explorer Sport Trac ..... | 2007-2010 |
| F-150 .....               | 2004-2008 |
| F-250/F-350/F-450/        |           |
| F-550 .....               | 2005-up   |
| F-650/F-750 .....         | 2011-up   |
| E-Series .....            | 2009-up   |
| F-Series Super Duty ..... | 2005-up   |
| Five-Hundred .....        | 2005-2007 |
| Focus .....               | 2005-2007 |
| FreeStar .....            | 2004-2007 |
| Freestyle .....           | 2005-2007 |
| Fusion .....              | 2006-2009 |
| Mustang.....              | 2005-2009 |
| Taurus .....              | 2008-2009 |
| Taurus X.....             | 2008-2009 |
| Transit.....              | 2012-up   |

### Lincoln

|  |           |
|--|-----------|
| Mark LT .....                          | 2006-2008 |
| <i>Factory navigation models only:</i> |           |
| MKX .....                              | 2007-2010 |
| Navigator.....                         | 2007-up   |

### Mercury

|                  |           |
|------------------|-----------|
| Monterey.....    | 2004-2007 |
| Milan .....      | 2006-2009 |
| Montego.....     | 2005-2007 |
| Mountaineer..... | 2006-2010 |
| Sable.....       | 2008-2009 |

## Table of Contents

### Dash Disassembly

|   |     |
|---|-----|
| – Ford E-Series 2009-up.....              | 7   |
| – Ford Edge 2007-2010.....                | 3   |
| – Ford Expedition 2007-up.....            | 3   |
| – Ford Explorer 2006-2010.....            | 7   |
| – Ford Explorer Sport Trac 2007-2010..... | 7   |
| – Ford F-150 2004-2008.....               | 3   |
| – Ford F-250/F-350/F-450/F-550.....       | 8   |
| – Ford F-650/F-750 2011-up.....           | 8   |
| – Ford F-Series Super Duty 2005-up.....   | 7   |
| – Ford Five Hundred 2005-2007.....        | 4   |
| – Ford Freestar 2004-2007.....            | 6   |
| – Ford Freestyle 2005-2007.....           | 5   |
| – Ford Focus 2005-2007.....               | 6   |
| – Ford Fusion 2006-2009.....              | 5   |
| – Ford Mustang 2005-2009.....             | 3-4 |
| – Ford Taurus 2008-2009.....              | 4   |
| – Ford Taurus X 2008 -2009.....           | 5   |
| – Ford Transit 2012-up.....               | 9   |
| – Lincoln Mark LT 2006-2008.....          | 3   |
| – Lincoln MKX* 2007-2010.....             | 8   |
| – Lincoln Navigator* 2007-up.....         | 9   |
| – Mercury Milan 2006-2009.....            | 5   |
| – Mercury Montego 2005-2007.....          | 4   |
| – Mercury Monterey 2004-2007.....         | 6   |
| – Mercury Mountaineer 2006-2010.....      | 7   |
| – Mercury Sable 2008-2009.....            | 4   |

### Kit Assembly

|  |    |
|--|----|
| – Double DIN radio provision.....      | 10 |
| – DIN radio provision with pocket..... | 11 |
| – ISO radio provision with pocket..... | 12 |

*\*Factory navigation models only*

### Ford Edge 2007-2010/F-150 2004-2008/Expedition 2007-up, Lincoln Mark LT 2006-2008

1. Unsnap and remove entire panel surrounding the radio and climate controls. (Figure A)

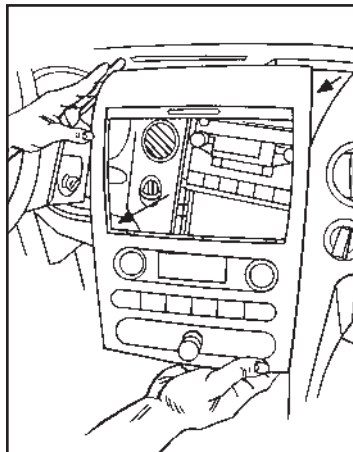

(Figure A)

2. Remove (4) 9/32" screws to remove the factory radio. (Figure B)

*Continue to kit assembly*

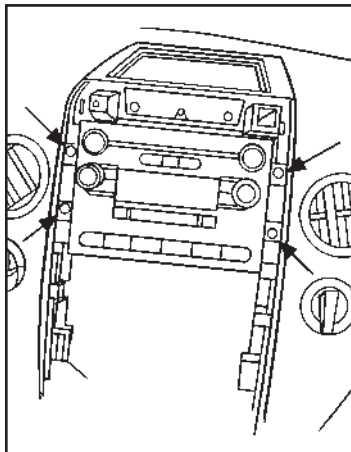

(Figure B)

### Ford Mustang 2005-2009

1. Remove the small rectangular shifter lever trim panel if equipped. (Figure A)
  2. Remove (2) Phillips screws from under the center armrest at the back of the shifter trim panel (including cup holders). (Figure B)
  3. Unclip and remove panel. (Figure B)
  4. Unclip and remove the (2) center stack trim panels from the left and right side of the radio and climate controls. (Figure C)
  5. Remove (6) 9/32" screws from center trim panel surrounding the radio and climate controls then unclip and remove panel. (Figure D, see next page)
  6. Remove (4) 9/32" screws from the radio to remove. (Figure E, see next page)
- Continue to kit assembly*

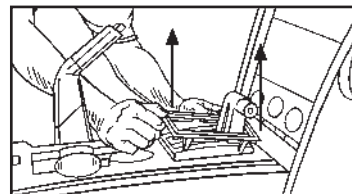

(Figure A)

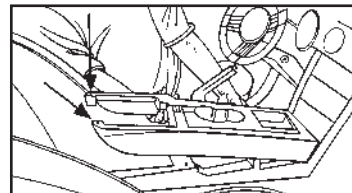

(Figure B)

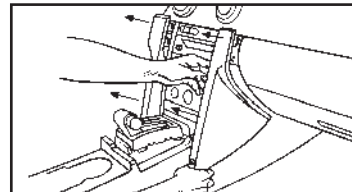

(Figure C)

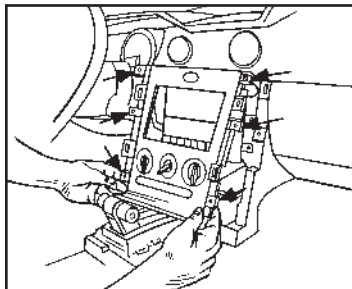
**Ford Mustang  
2005-2009****Ford Five-Hundred 2005-2007/Taurus 2008-2009,  
Mercury Montego 2005-2007/Sable 2008-2009***(Figure D)*

1. Unclip and remove the small rectangular trim around shift lever. (Figure A)
2. Unclip and remove the entire panel (including cup holders) surrounding the shift lever. (Figure B)
3. Remove (2) 9/32" screws at the bottom of the center radio/climate control panel. (Figure C)
4. Unclip and remove the center panel. (Figure D)
5. Remove (4) 9/32" screws from the radio to remove. (Figure E)

*Continue to kit assembly*

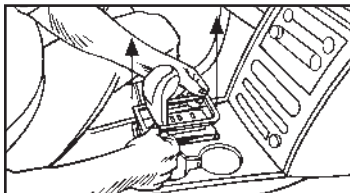
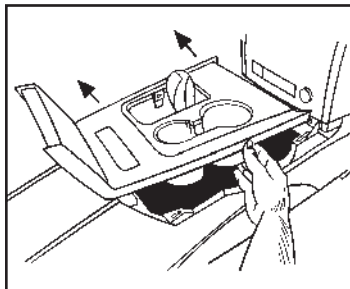
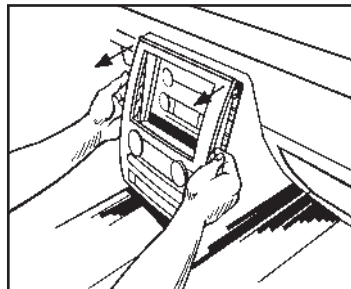
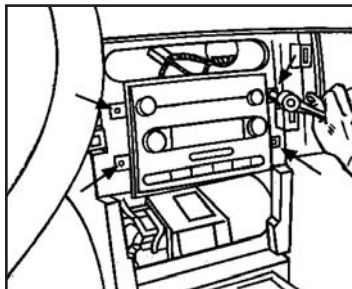
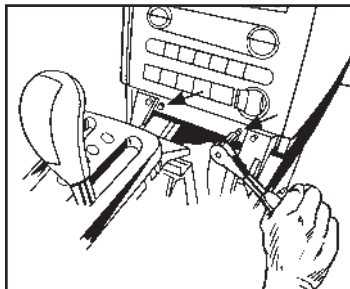
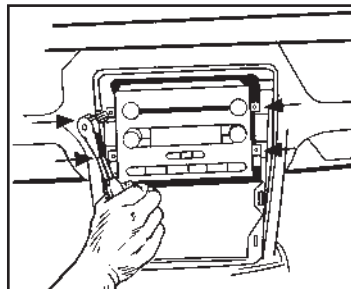
*(Figure A)**(Figure B)**(Figure D)**(Figure E)**(Figure C)**(Figure E)*

## Ford Fusion 2006-2009 Mercury Milan 2006-2009

1. Unsnap and remove entire panel surrounding the radio and climate controls. (Figure A)
2. Remove (4) 9/32" screws to remove the factory radio. (Figure B)  
*Continue to kit assembly*

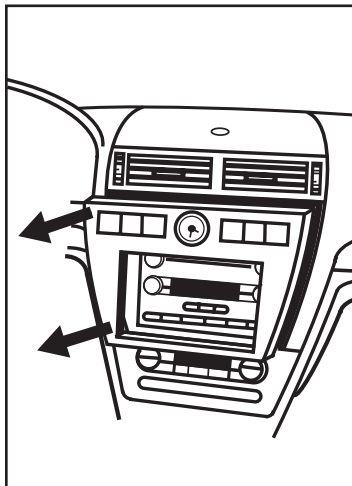

(Figure A)

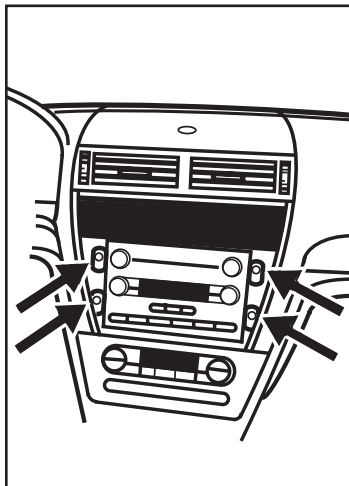

(Figure B)

## Ford Freestyle 2005-2007 Ford Taurus X 2008-2009

1. Unclip and remove entire panel surrounding the radio and A/C controls. (Figure A)
2. Remove (4) 9/32" screws from radio to remove. (Figure B)  
*Continue to kit assembly*

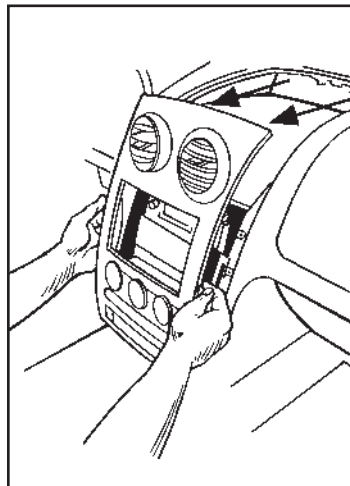

(Figure A)

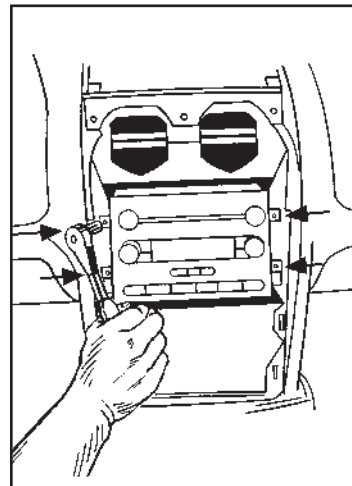

(Figure B)

**Ford Freestar 2004-2007  
Mercury Monterey 2004-2007**

1. Unsnap and remove entire panel surrounding the radio and climate controls. (Figure A)
2. Remove (4) 9/32" screws to remove the factory radio. (Figure B)  
*Continue to kit assembly*

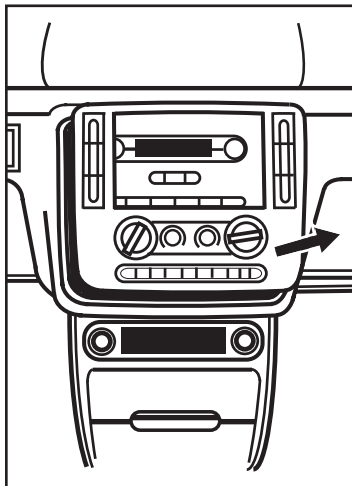

(Figure A)

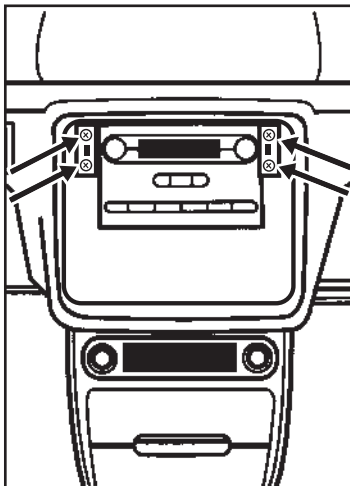

(Figure B)

**Ford Focus  
2005-2007**

1. Unsnap and remove entire panel surrounding the radio and climate controls. (Figure A)
2. Remove (4) 9/32" screws to remove the factory radio. (Figure B)  
*Continue to kit assembly*

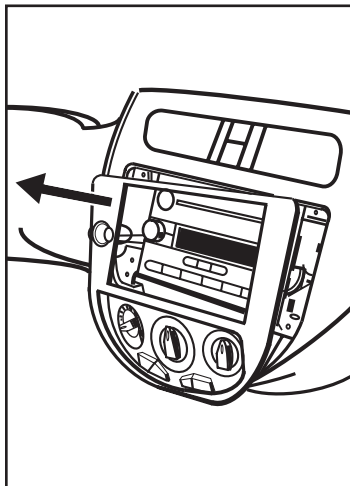

(Figure A)

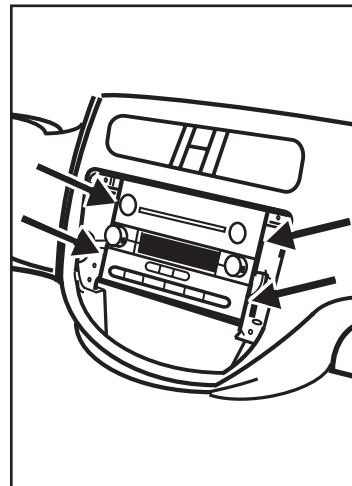

(Figure B)

### Ford Explorer 2006-2010 Ford Sport Trac 2007-2010 Mercury Mountaineer 2006-2010

1. Open center console and remove (2) Phillips screws then unclip and remove entire panel surrounding shifter. (Figure A)
2. Remove dash panel surrounding radio to access the factory radio screws. (Figure B)
3. Remove (4) 9/32" screws to remove the factory radio. (Figure C)

*Continue to kit assembly*

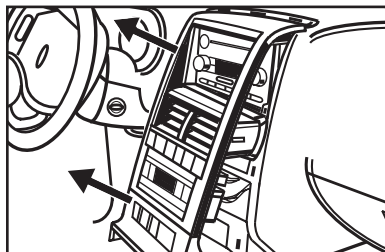

(Figure B)

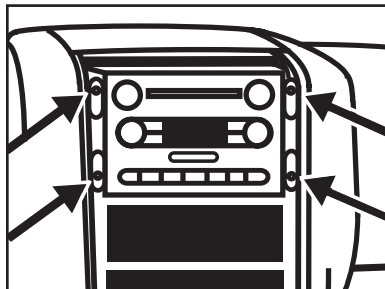

(Figure C)

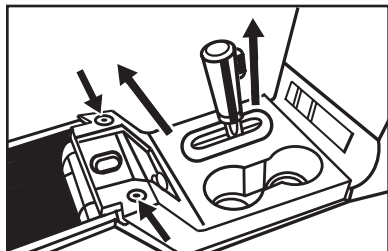

(Figure A)

### Ford E-Series 2009-up, Ford F-Series Super Duty 2005-up

1. Unsnap and remove entire panel surrounding the radio and climate controls. (Figure A)
2. Remove (4) 9/32" screws to remove the factory radio. (Figure B)

*Continue to kit assembly*

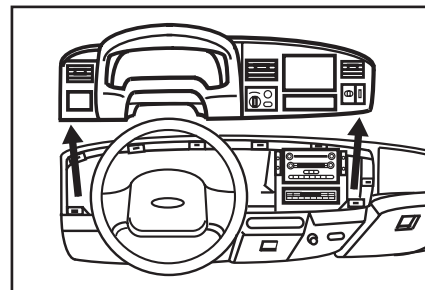

(Figure A)

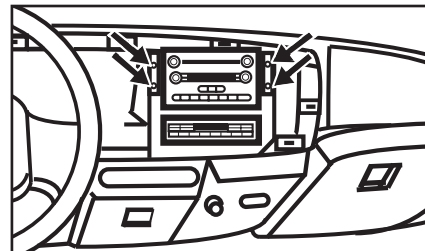

(Figure B)

### Ford Super Duty F-250/F-350/ F-450/F-550 2005-up, Ford Super Duty F-650/F-750 2011-up

1. Unclip and remove the power outlet panel and the blank panel on the left and right side of the radio trim panel. (Figure A)
2. Remove the (2) 9/32" screws exposed behind the two panels previously removed.
3. Unclip and remove the entire radio trim panel including the A/C control and vents.
4. Remove (4) 9/32" screws securing the radio.
 

*Continue to kit assembly*

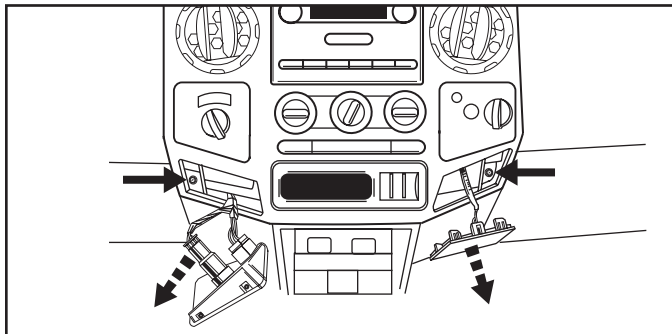

(Figure A)

### Lincoln MKX 2007-2010

*(Factory navigation models only)*

1. Open center console lid and unclip and remove the center console trim panel surrounding the shifter. (Figure A)
2. Remove (2) Phillips screws from the storage bin then unclip and remove the bin. (Figure B)
3. Unclip and remove the upper and lower center trim panel as one assembly. (Figure C)
4. Remove (4) 9/32" screws securing the radio. Unplug and remove the radio.
 

*Continue to kit assembly*

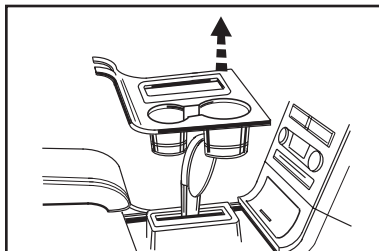

(Figure A)

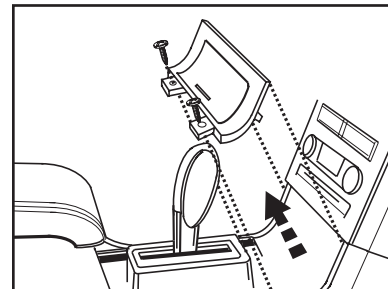

(Figure B)

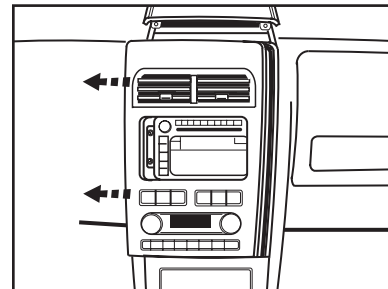

(Figure C)



### Lincoln Navigator 2007-up

*(Factory navigation models only)*

1. Unclip and remove the panel surrounding the shifter. (Figure A)
2. Remove (2) 9/32" screws from the bottom of the radio/climate control trim panel. (Figure B)
3. Unclip and remove the entire panel

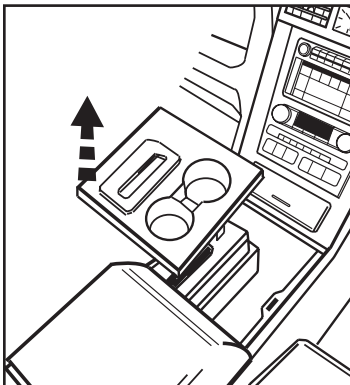

(Figure A)

4. Remove (4) 9/32" screws securing the radio. Unplug and remove the radio.

*Continue to kit assembly*

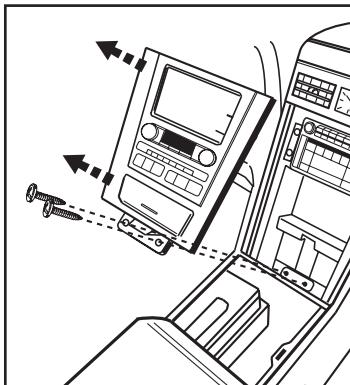

(Figure B)

### Ford Transit

### 2012-up

1. Unclip the dash panel and remove. (Figure A)
2. Remove four screws securing the radio to the dash and remove. (Figure B)

*Continue to kit assembly*

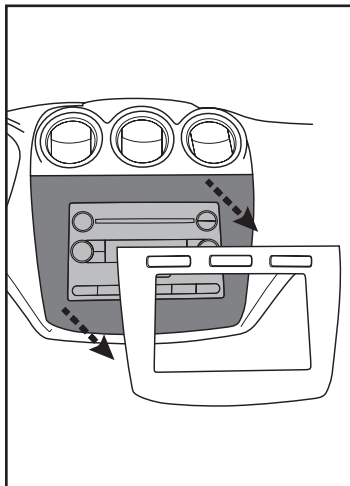

(Figure A)

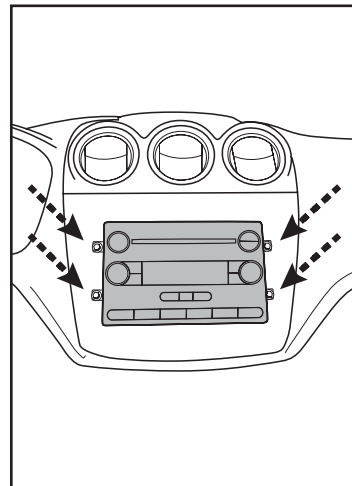

(Figure B)

## Double DIN radio provision

1. For the Ford Freestar 2004-2007, Mercury Monterey 2004-2007, Ford Focus 2005-2007 and the Ford F Series Super Duty 2005-up: **Do not cut the rear mounting tabs from the double DIN brackets.** If your vehicle is not listed above move to step 2.
2. If your vehicle was not listed above, attach the included spacers to the back of the radio housing mounting tabs. (Figure A)

**Note:** Use the screws supplied with this kit to mount the radio housing in the vehicles that require the spacers. Not all vehicles will require spacers.

3. Cut and remove the rear mounting tabs on the double DIN bracket. (Figure B)
4. Attach the double DIN brackets to the radio housing. (Figure C)

**Note:** The notch in the housing should be on top.

5. Slide the double DIN radio into the radio housing/bracket assembly and secure the radio to the assembly using the screws supplied with the radio. (Figure D)
6. Locate the factory wiring harness in the dash. Metra recommends using the proper mating adapter from Metra or AXXESS. Re-connect the negative battery terminal and test the unit for proper operation.
7. Reassemble dash in reverse order of disassembly.

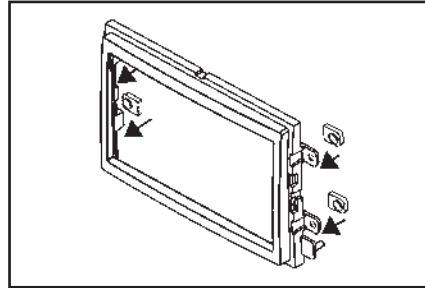

(Figure A)

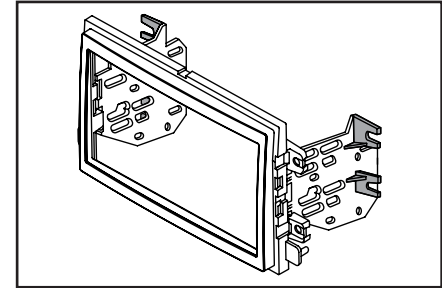

(Figure B)

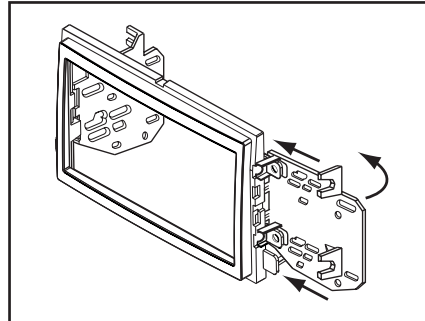

(Figure C)

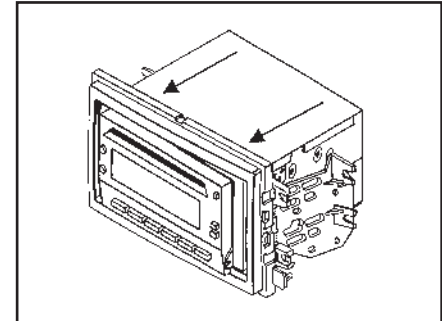

(Figure D)

## DIN radio provision with pocket

1. For the Ford Freestar 2004-2007, Mercury Monterey 2004-2007, Ford Focus 2005-2007 and the Ford F Series Super Duty 2005-up, slide the included brackets onto the sides of the radio housings pocket from the back of the housing forward. (Figure A)

If your vehicle is not listed above do not use brackets and move to step 2.

2. Attach the included spacers to the back of the radio housing mounting tabs. (Figure B)

**Note:** Use the screws supplied with this kit to mount the radio housing in the vehicles that require the spacers. Not all vehicles will require spacers.

3. Locate the factory wiring harness in the dash. Metra recommends using the proper mating adapter from Metra or AXCESS. Re-connect the negative battery terminal and test the unit for proper operation.
4. Slide the DIN cage into the radio housing and secure by bending the metal locking tabs outward. (Figure C)
5. Slide the aftermarket radio into the cage until it snaps in place. (Figure D)
6. Reassemble dash in reverse order of disassembly.

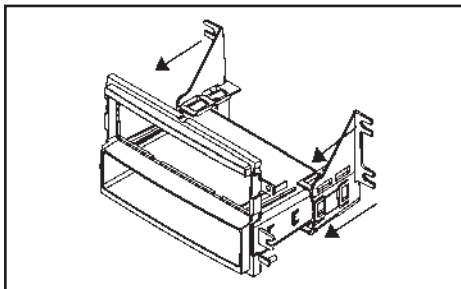

(Figure A)

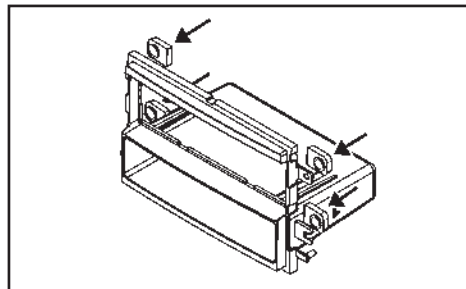

(Figure B)

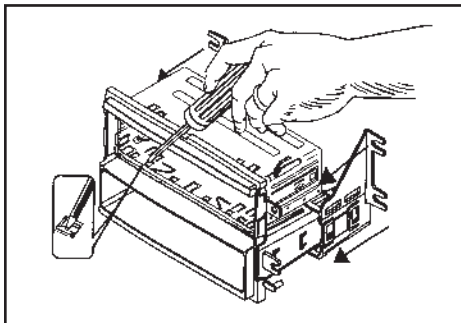

(Figure C)

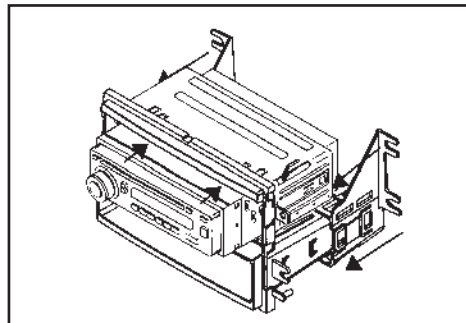

(Figure D)



## Kit Assembly 99-5812

### ISO radio provision with pocket

1. For the Ford Freestar 2004-2007, Mercury Monterey 2004-2007, Ford Focus 2005-2007 and the Ford F Series Super Duty 2005-up, slide the included brackets onto the sides of the radio housings pocket from the back of the housing forward. (Figure A)

If your vehicle is not listed above do not use brackets and move to step 2.

2. Attach the included spacers to the back of the radio housing mounting tabs. (Figure B)

**Note:** Use the screws supplied with this kit to mount the radio housing in the vehicles that require the spacers. Not all vehicles will require spacers.

3. Locate the factory wiring harness in the dash. Metra recommends using the proper mating adapter from Metra or AXCESS. Re-connect the negative battery terminal and test the unit for proper operation.
4. Mount the ISO brackets to the head unit with the screws supplied with the unit. (Figure C)
5. Slide the head unit into the radio opening until the side clips engage. (Figure D)
6. Snap the Trim plate into the radio housing. (Figure D)
7. Reassemble dash in reverse order of disassembly.

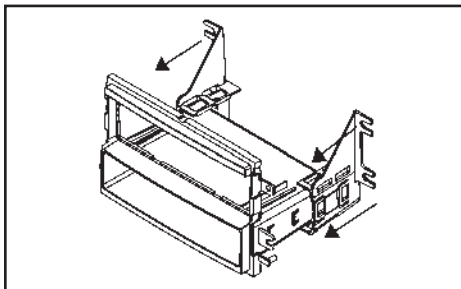

(Figure A)

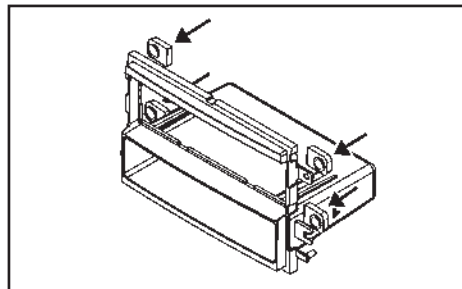

(Figure B)

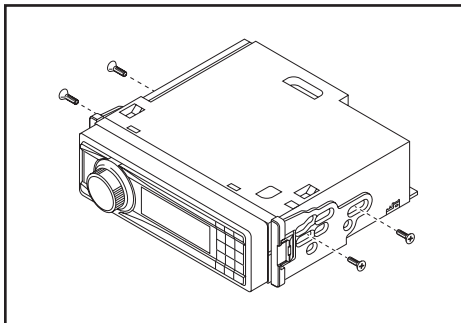

(Figure C)

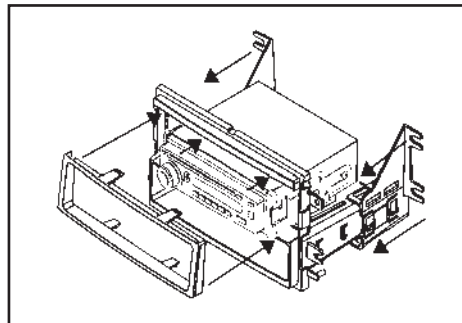

(Figure D)









INSTALLATION INSTRUCTIONS FOR PART 95-5812 or 99-5812



REV. 2/10/2014 INST-5812



### KNOWLEDGE IS POWER

Enhance your installation and fabrication skills by enrolling in the most recognized and respected mobile electronics school in our industry. Log onto [www.installerinstitute.com](http://www.installerinstitute.com) or call 800-354-6782 for more information and take steps toward a better tomorrow.



**Metra recommends MECP certified technicians**





## INSTRUCCIONES DE INSTALACIÓN PARA LA PIEZA 95-5812 o 99-5812

### APLICACIONES

See application list inside

## Ford multi-kit 2004 y mas 95-5812 o 99-5812

### CARACTERÍSTICAS DEL KIT

95-5812:

- Provisión de radio doble DIN

99-5812:

- Provisión de radio DIN con bolsillo
- Provisión de radio ISO con bolsillo



### COMPONENTES DEL KIT

95-5812: • A1 Alojamiento del radio (DIN dobles y DIN ISO)

- B1 Soportes DIN dobles • C1 Espaciadores • D1 (4) Tornillos

99-5812: • A2 Alojamiento del radio • B2 Soportes ISO • C2 Placa de terminación

- D2 Soportes laterales • E2 Espaciadores • F2 (4) Tornillos

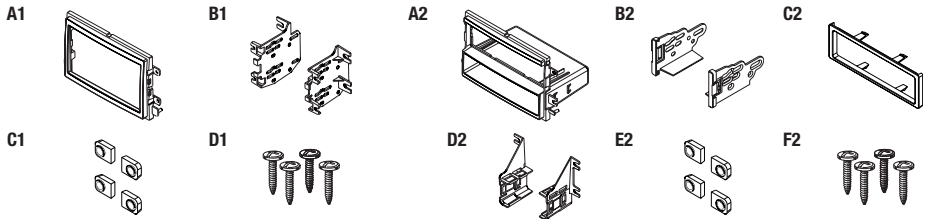

### CABLEADO Y CONEXIONES DE ANTENA

Arnés de cableado: (se venden por separado)

- 70-5520 - Ford harness 2003 y mas
- 70-5521 - Ford amplified harness 2003 y mas
- 70-5522 - Ford sub harness 2003 y mas
- XSVI-5520 - NAV Ford interface 2006 y mas

Adaptador de antena:

- 40-CR10 - Chrysler/GM antenna adapter 2002 y mas

### HERRAMIENTAS REQUERIDAS

- Herramienta de remoción de panel
- Destornillador Phillips • Llave de tubo

**PRECAUCIÓN:** Metra recomienda desconectar el terminal negativo de la batería antes de comenzar cualquier instalación. Todos los accesorios, interruptores y, especialmente, las luces indicadoras de airbag deben estar enchufados antes de volver a conectar la batería o comenzar el ciclo de ignición.

**NOTA:** Remítase a las instrucciones incluidas con el radio de postventa.

REV. 2/10/2014 INST-5812

## Aplicaciones

### Ford

|                                   |            |
|-----------------------------------|------------|
| Edge.....                         | 2007-2010  |
| Expedition .....                  | 2007 y mas |
| Explorer.....                     | 2006-2010  |
| Explorer Sport Trac .....         | 2007-2010  |
| F-150 .....                       | 2004-2008  |
| F-250/F-350/F-450/<br>F-550 ..... | 2005 y mas |
| F-650/F-750 .....                 | 2011 y mas |
| E-Series .....                    | 2009 y mas |
| F-Series Super Duty .....         | 2005 y mas |
| Five-Hundred .....                | 2005-2007  |
| Focus .....                       | 2005-2007  |
| FreeStar .....                    | 2004-2007  |
| Freestyle .....                   | 2005-2007  |
| Fusion .....                      | 2006-2009  |
| Mustang.....                      | 2005-2009  |
| Taurus .....                      | 2008-2009  |
| Taurus X.....                     | 2008-2009  |
| Transit.....                      | 2012 y mas |

### Lincoln

|   |            |
|---|------------|
| Mark LT .....                                 | 2006-2008  |
| <i>Modelos de fábrica de navegación sólo:</i> |            |
| MKX .....                                     | 2007-2010  |
| Navigator.....                                | 2007 y mas |

### Mercury

|                  |           |
|------------------|-----------|
| Monterey.....    | 2004-2007 |
| Milan .....      | 2006-2009 |
| Montego.....     | 2005-2007 |
| Mountaineer..... | 2006-2010 |
| Sable.....       | 2008-2009 |

## Indice

### Desmontaje del tablero

|  |     |
|--|-----|
| – Ford E-Series 2009 y mas.....            | 7   |
| – Ford Edge 2007-2010.....                 | 3   |
| – Ford Expedition 2007 y mas.....          | 3   |
| – Ford Explorer 2006-2010.....             | 7   |
| – Ford Explorer Sport Trac 2007-2010.....  | 7   |
| – Ford F-150 2004-2008.....                | 3   |
| – Ford F-250/F-350/F-450/F-550.....        | 8   |
| – Ford F-650/F-750 2011 y mas.....         | 8   |
| – Ford F-Series Super Duty 2005 y mas..... | 7   |
| – Ford Five Hundred 2005-2007.....         | 4   |
| – Ford Freestar 2004-2007.....             | 6   |
| – Ford Freestyle 2005-2007.....            | 5   |
| – Ford Focus 2005-2007.....                | 6   |
| – Ford Fusion 2006-2009.....               | 5   |
| – Ford Mustang 2005-2009.....              | 3-4 |
| – Ford Taurus 2008-2009.....               | 4   |
| – Ford Taurus X 2008 -2009.....            | 5   |
| – Ford Transit 2012 y mas.....             | 9   |
| – Lincoln Mark LT 2006-2008.....           | 3   |

|                                      |   |
|--------------------------------------|---|
| – Lincoln MKX* 2007-2010.....        | 8 |
| – Lincoln Navigator* 2007 y mas..... | 9 |
| – Mercury Milan 2006-2009.....       | 5 |
| – Mercury Montego 2005-2007.....     | 4 |
| – Mercury Monterey 2004-2007.....    | 6 |
| – Mercury Mountaineer 2006-2010..... | 7 |
| – Mercury Sable 2008-2009.....       | 4 |

### Ensamble del kit

|  |    |
|--|----|
| – Provisión de radio doble DIN.....        | 10 |
| – Provisión de radio DIN con bolsillo..... | 11 |
| – Provisión de radio ISO con bolsillo..... | 12 |

\*Modelos de fábrica de navegación sólo

### **Ford Edge 2007-2010/F-150 2004-2008/Expedition 2007 y mas, Lincoln Mark LT 2006-2008**

1. Quite a presión y retire todo el panel que rodea el radio y los controles de clima. (Figura A)
2. Retire (4) tornillos de 9/32 in para retirar el radio de fábrica. (Figura B)

*Continuará al ensamble del kit*

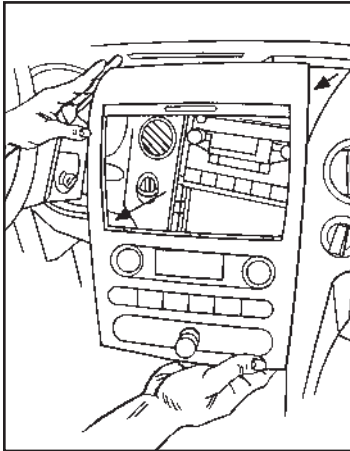

(Figura A)

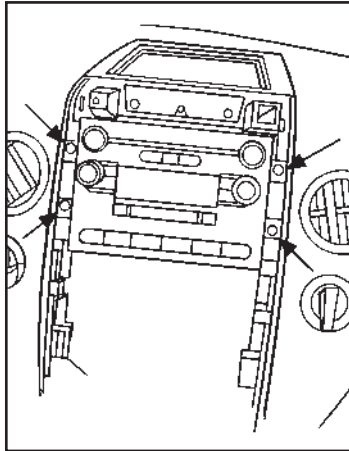

(Figura B)

### **Ford Mustang 2005-2009**

1. Retire el panel de terminación pequeño rectangular de la palanca de velocidades, si corresponde. (Figura A)
2. Retire (2) tornillos Phillips que se encuentran debajo del apoyabrazos central en la parte posterior del panel de terminación de la palanca de velocidades (incluidos los portavasos). (Figura B)
3. Desenganche y retire el panel. (Figura B)
4. Desenganche y retire los (2) paneles de terminación apilados centrales de los lados izquierdo y derecho del radio y de los controles de clima. (Figura C)
5. Retire (6) tornillos de 9/32 in del panel de terminación central que rodea el radio y los controles de clima y, luego, desenganche y retire el panel. (Figura D, página siguiente)
6. Retire (4) tornillos de 9/32 in del radio para retirarlo. (Figura E, página siguiente)

*Continuará al ensamble del kit*

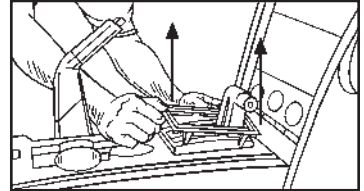

(Figura A)

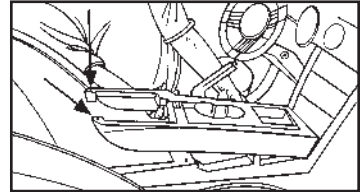

(Figura B)

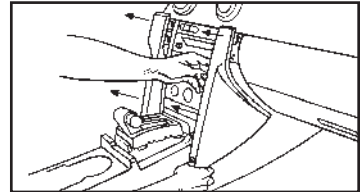

(Figura C)

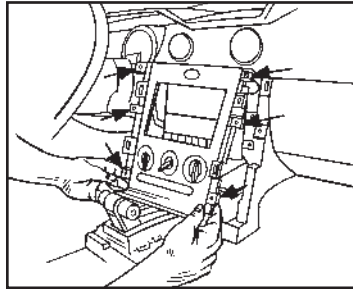
**Ford Mustang  
2005-2009****Ford Five-Hundred 2005-2007/Taurus 2008-2009,  
Mercury Montego 2005-2007/Sable 2008-2009**

(Figura D)

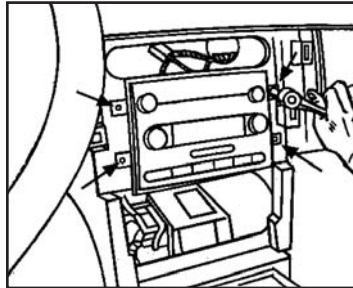

(Figura E)

1. Desenganche y retire la terminación pequeña rectangular que rodea la palanca de velocidades. (Figura A)
2. Desenganche y retire todo el panel (incluidos los portavasos) que rodean la palanca de velocidades. (Figura B)
3. Retire (2) 9/32 tornillos en la parte inferior del panel central de control de radio/clima. (Figura C)
4. Desenganche y retire el panel central. (Figura D)
5. Retire (4) tornillos de 9/32 in para retirar el radio de fábrica. (Figura E)  
*Continuará al ensamble del kit*

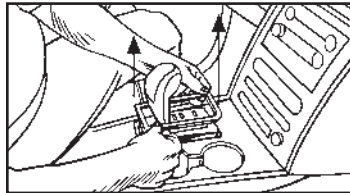

(Figura A)

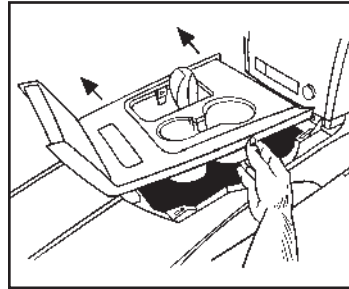

(Figura B)

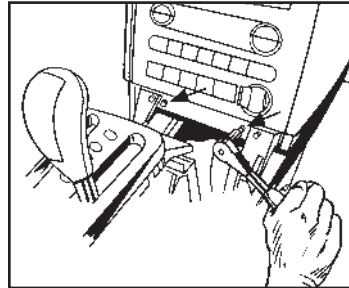

(Figura C)

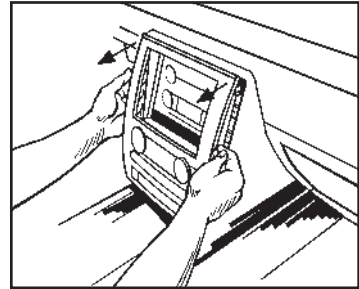

(Figura D)

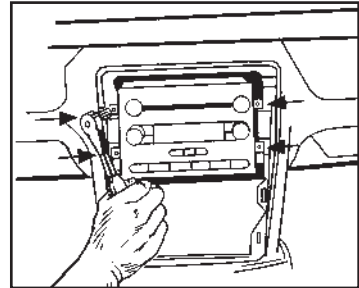

(Figura E)

**Ford Fusion 2006-2009  
Mercury Milan 2006-2009**

1. Quite a presión y retire todo el panel que rodea el radio y los controles de clima. (Figura A)
2. Retire (4) tornillos de 9/32 in para retirar el radio de fábrica. (Figura B)  
*Continuará al ensamble del kit*

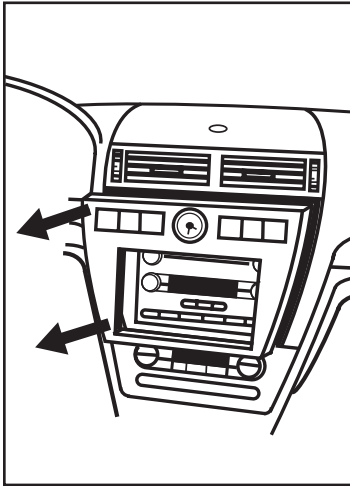

(Figura A)

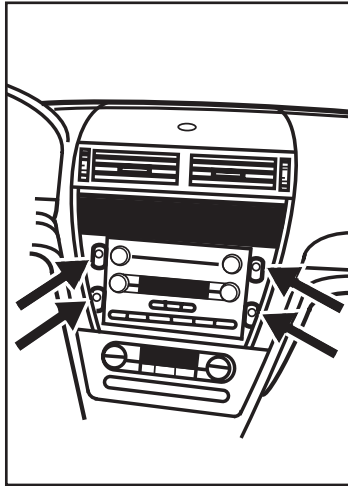

(Figura B)

**Ford Freestyle 2005-2007  
Ford Taurus X 2008-2009**

1. Unclip and remove entire panel surrounding the radio and A/C controls. (Figura A)
2. Remove (4) 9/32" screws from radio to remove. (Figura B)  
*Continuará al ensamble del kit*

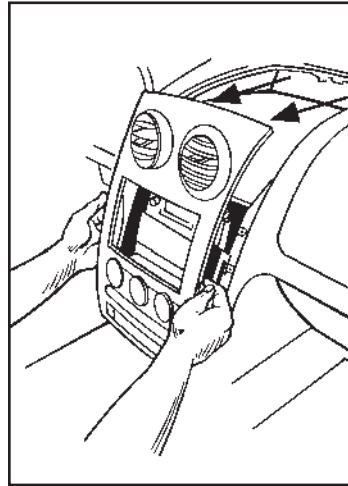

(Figura A)

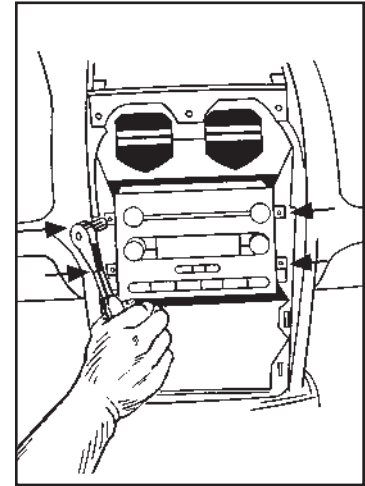

(Figura B)

**Ford Freestar 2004-2007  
Mercury Monterey 2004-2007**

1. Quite a presión y retire todo el panel que rodea el radio y los controles de clima. (Figura A)
2. Retire (4) tornillos de 9/32 in para retirar el radio de fábrica. (Figura B)  
*Continuará al ensamble del kit*

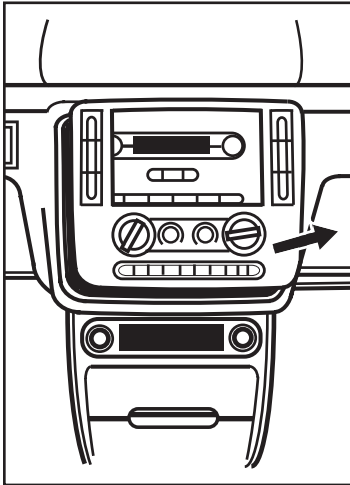

(Figura A)

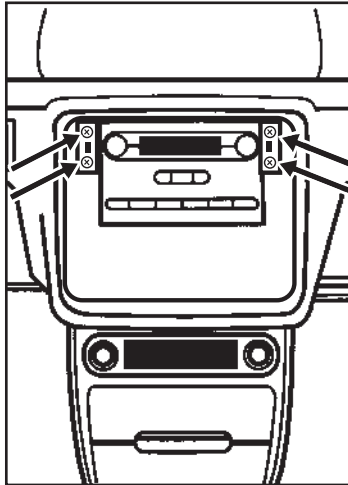

(Figura B)

**Ford Focus  
2005-2007**

1. Quite a presión y retire todo el panel que rodea el radio y los controles de clima. (Figura A)
2. Retire (4) tornillos de 9/32 in para retirar el radio de fábrica. (Figura B)  
*Continuará al ensamble del kit*

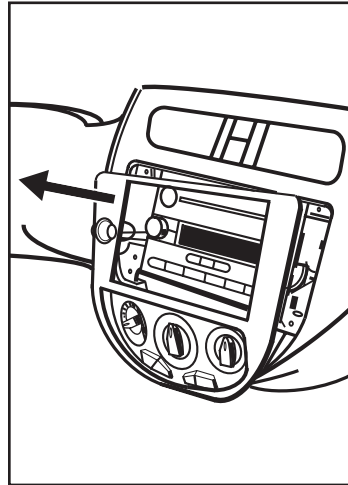

(Figura A)

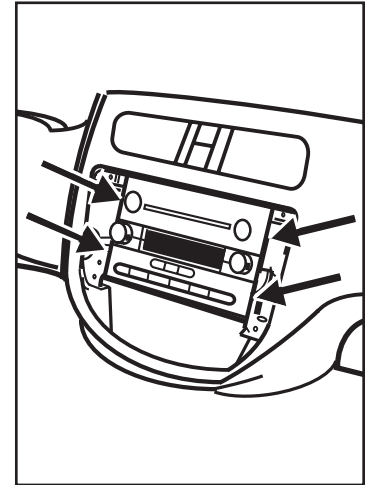

(Figura B)

**Ford Explorer 2006-2010  
Ford Sport Trac 2007-2010  
Mercury Mountaineer 2006-2010**

1. Abra la consola central y retire (2) tornillos Phillips y, luego, desenganche y retire todo el panel que rodea la palanca de velocidades. (Figura A)
2. Retire el panel del tablero que rodea el radio para tener acceso a los tornillos del radio de fábrica. (Figura B)
3. Retire (4) tornillos de 9/32 in para retirar el radio de fábrica. (Figura C)

*Continuará al ensamble del kit*

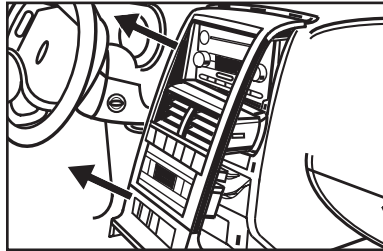

(Figura B)

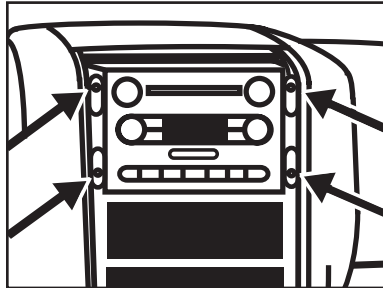

(Figura C)

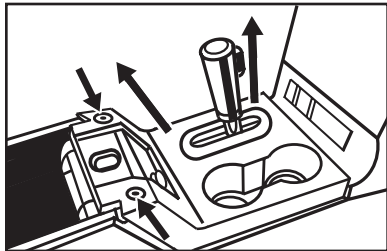

(Figura A)

**Ford E-Series 2009 y mas,  
Ford F-Series Super Duty  
2005 y mas**

1. Quite a presión y retire todo el panel que rodea el radio y los controles de clima. (Figura A)
2. Retire (4) tornillos de 9/32 in para retirar el radio de fábrica. (Figura B)

*Continuará al  
ensamble del kit*

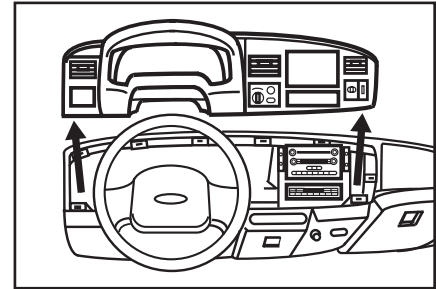

(Figura A)

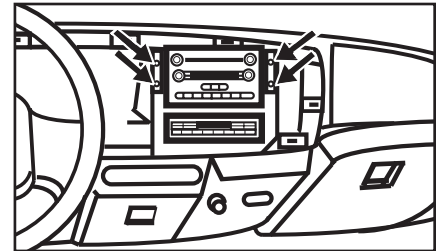

(Figura B)

### Ford Super Duty F-250/F-350/ F-450/F-550 2005 y mas, Ford Super Duty F-650/F-750 2011 y mas

1. Desenganche y retire el panel de salida de alimentación eléctrica y el panel en blanco en los lados izquierdo y derecho del panel de terminación del radio. (Figura A)
2. Retire los (2) tornillos de 9/32 in expuestos detrás de los dos paneles que se retiraron.
3. Desenganche y retire todo el panel de terminación del radio, incluidos el control del aire acondicionado y las rejillas de ventilación.
4. Retire (4) tornillos de 9/32 in que sujetan el radio. *Continuará al ensamble del kit*

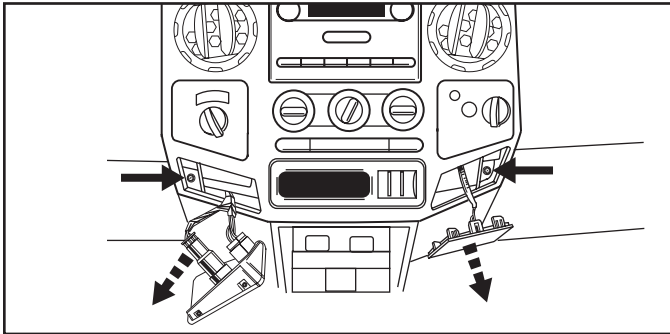

(Figura A)

### Lincoln MKX 2007-2010 (Modelos de fábrica de navegación sólo)

1. Abra la tapa de la consola central, y desenganche y retire el panel de terminación de la consola central que rodea la palanca de velocidades. (Figura A)
2. Retire (2) tornillos Phillips del recipiente de almacenamiento y, luego, desenganche y retire el recipiente. (Figura B)
3. Desenganche y retire el panel de terminación central superior e inferior como un conjunto. (Figura C)
4. Retire (4) tornillos de 9/32 in que sujetan el radio. Desenchufe y retire el radio. *Continuará al ensamble del kit*

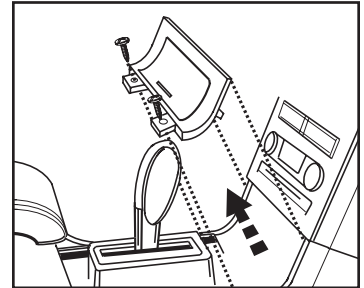

(Figura B)

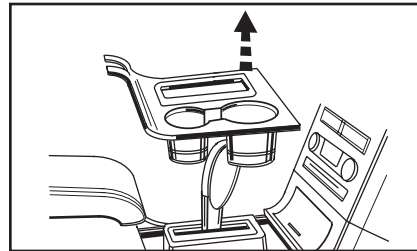

(Figura A)

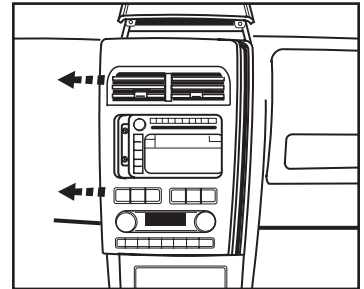

(Figura C)



### Lincoln Navigator 2007 y mas

(Modelos de fábrica de navegación sólo)

1. Desenganche y retire el panel que rodea la palanca de velocidades. (Figura A)
2. Retire (2) tornillos de 9/32 in de la parte inferior del panel de terminación del radio/control de clima. (Figura B)
3. Desenganche y retire todo el panel que rodea el radio y que incluye los controles de clima. (Figura B)
4. Retire (4) tornillos de 9/32 in que sujetan el radio. Desenchufe y retire el radio.

*Continuará al ensamble del kit*

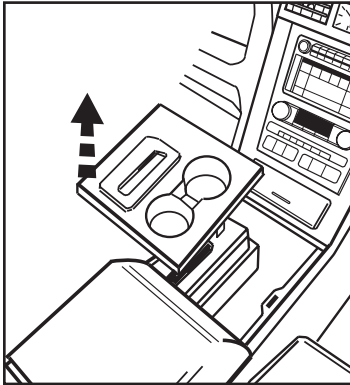

(Figura A)

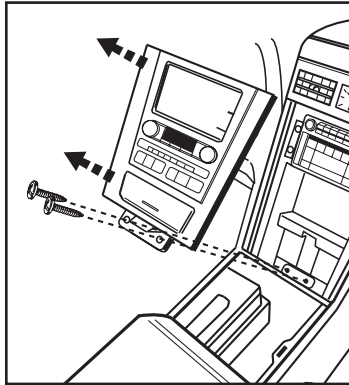

(Figura B)

### Ford Transit 2012 y mas

**2012 y mas**

1. Suelte el panel de instrumentos y quitar. (Figura A)
2. Retire los cuatro tornillos que sujetan el radio en el tablero y quitar. (Figura B)

*Continuará al ensamble del kit*

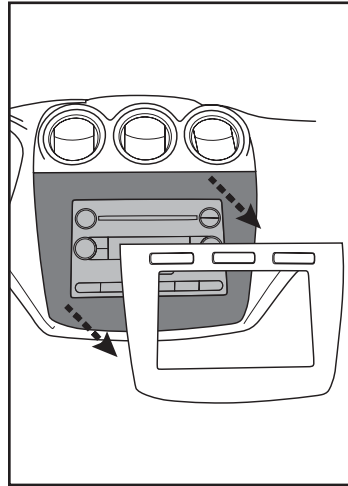

(Figura A)

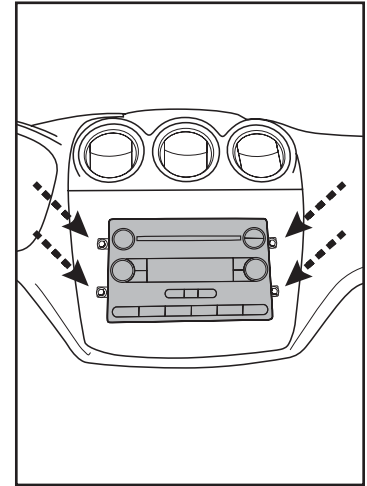

(Figura B)

## Provisión de radio doble DIN

1. Para los modelos Ford Freestar 2004-2007, Mercury Monterey 2004-2007, Ford Focus 2005-2007, and the Ford F Series Super Duty 2005 y más recientes: **No corte las lengüetas de montaje traseros de los soportes de doble DIN.** Si su vehículo no está en la lista vaya al paso 2.
2. Si su vehículo no fue mencionado anteriormente, coloque los espaciadores que se incluyen en la parte posterior de las lengüetas de montaje de radio de vivienda. (Figura A)

**Nota:** Use los tornillos suministrados con este kit para montar la carcasa de la radio en los vehículos que requieren los espaciadores. No todos los vehículos requieren espaciadores.

3. Corte y retire las lengüetas de montaje posterior del soporte de doble DIN. (Figura B)
4. Fije los soportes de doble DIN a la carcasa de la radio. (Figura C)

**Nota:** La muesca de la vivienda debe estar en la cima.

5. Deslice el radio DIN doble en el conjunto del alojamiento del radio/soporte y sujete el radio en el montaje usando los tornillos suministrados con el radio. (Figura D)
6. Ubique el arnés del cableado de fábrica en el tablero. Metra recomienda usar el adaptador de acoplamiento adecuado de Metra o AXCESS. Vuelva a conectar el terminal negativo de la batería y pruebe la unidad para verificar que funcione correctamente.
7. Vuelva a montar el tablero en forma inversa al desmontaje.

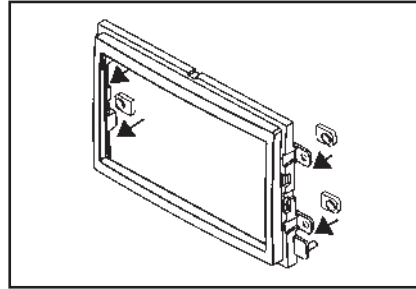

(Figura A)

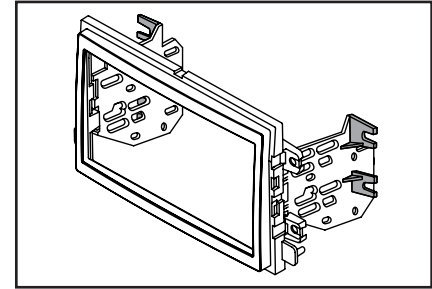

(Figura B)

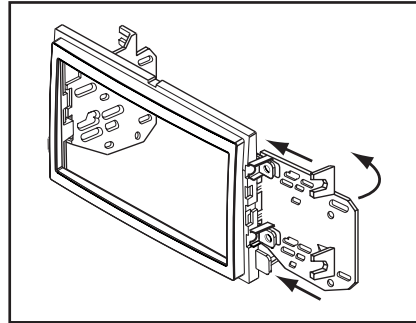

(Figura C)

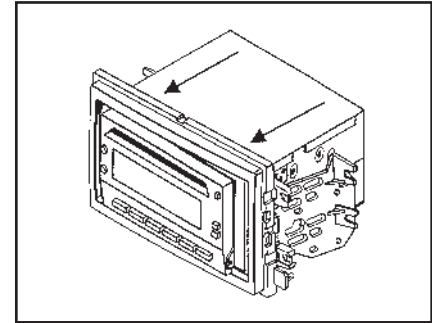

(Figura D)

## Provisión de radio DIN con bolsillo

1. Para los modelos Ford Freestar 2004-2007, Mercury Monterey 2004-2007, Ford Focus 2005-2007, and the Ford F Series Super Duty 2005 y más recientes, deslice los soportes en los lados de alojamiento del radio bolliso de la parte posterior de la alojamiento, hacia delante. (Figura A)

Si su vehículo no se incluyó antes, continúe con el paso 2.

2. Fije los espaciadores que se incluyen en la parte posterior de las lengüetas de montaje de cubierta de radio. (Figura B)

**Nota: Use los tornillos suministrados con este kit para montar la carcasa de la radio en los vehículos que requieren los espaciadores. No todos los vehículos se requieren espaciadores.**

3. Ubique el arnés del cableado de fábrica en el tablero. Metra recomienda usar el adaptador de acoplamiento adecuado de Metra o AXXESS. Vuelva a conectar el terminal negativo de la batería y pruebe la unidad para verificar que funcione correctamente.
4. Deslice la caja DIN en el alojamiento del radio y sujétela doblando las lengüetas de cierre de metal hacia afuera. (Figura C)
5. Deslice el radio de posventa en la caja hasta que calce a presión en su lugar. (Figura D)
6. Vuelva a montar el tablero en forma inversa al desmontaje.

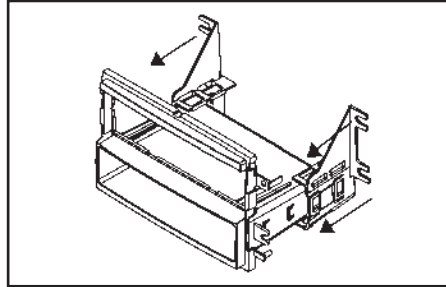

(Figura A)

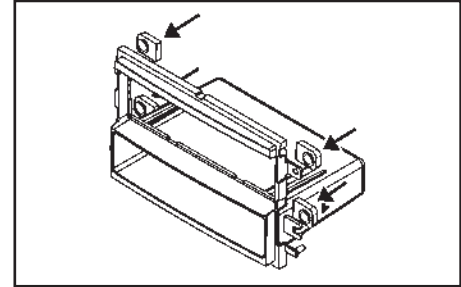

(Figura B)

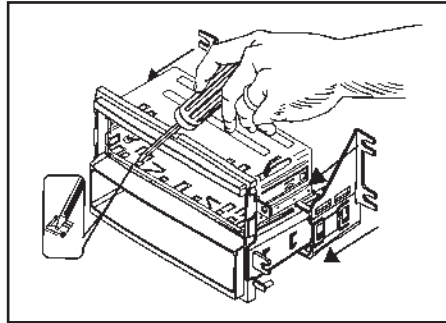

(Figura C)

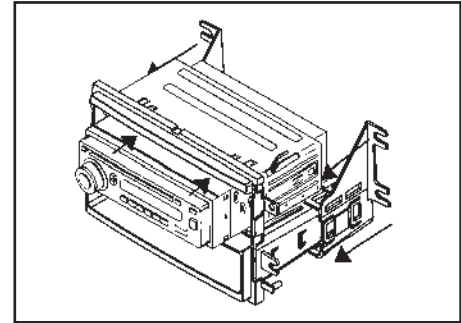

(Figura D)

## Provisión de radio ISO con bolsillo

1. Para los modelos Ford Freestar 2004-2007, Mercury Monterey 2004-2007, Ford Focus 2005-2007, and the Ford F Series Super Duty 2005 y más recientes, deslice los soportes en los lados de alojamiento del radio bolliso de la parte posterior de la alojamiento, hacia delante. (Figura A)

Si su vehículo no se incluyó antes, continúe con el paso 2.

2. Fije los espaciadores que se incluyen en la parte posterior de las lengüetas de montaje de cubierta de radio. (Figura B)

**Nota: Use los tornillos suministrados con este kit para montar la carcasa de la radio en los vehículos que requieren los espaciadores. No todos los vehículos se requieren espaciadores.**

3. Ubique el arnés del cableado de fábrica en el tablero. Metra recomienda usar el adaptador de acoplamiento adecuado de Metra o AXCESS. Vuelva a conectar el terminal negativo de la batería y pruebe la unidad para verificar que funcione correctamente.
4. Monte los soportes ISO en la unidad central con los tornillos suministrados con la unidad. (Figura C)
5. Deslice la unidad central dentro de la abertura del radio hasta que se enganchen los ganchos. (Figura D)
6. Coloque a presión la placa de terminación en el alojamiento del radio. (Figura D)
7. Vuelva a montar el tablero en forma inversa al desmontaje.

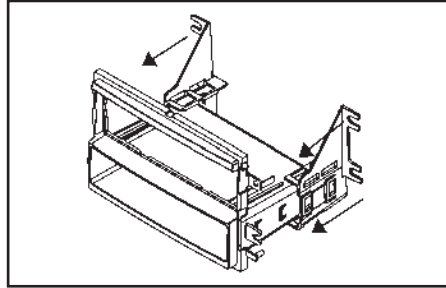

(Figura A)

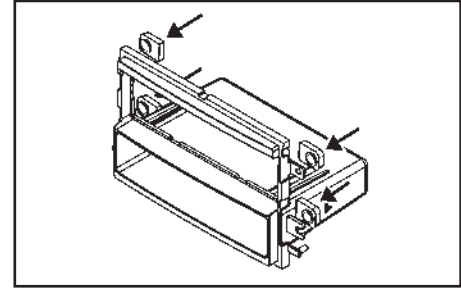

(Figura B)

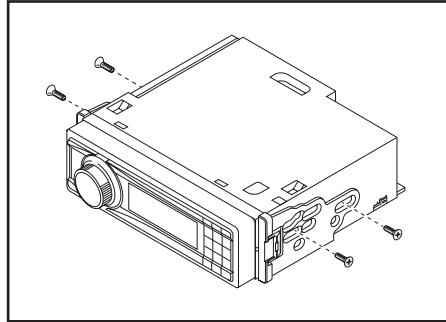

(Figura C)

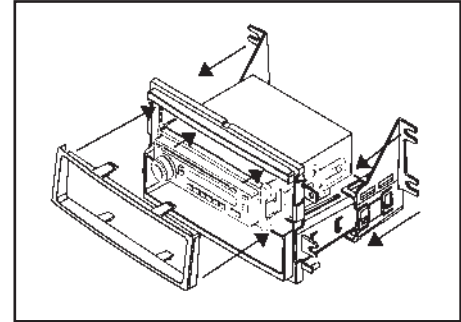

(Figura D)









INSTRUCCIONES DE INSTALACIÓN PARA LA PIEZA 95-5812 o 99-5812



REV. 2/10/2014 INST-5812



**EL CONOCIMIENTO ES PODER**  
Mejore sus habilidades de instalación y fabricación inscribiéndose en la escuela de dispositivos electrónicos móviles más reconocida y respetada de nuestra industria. Regístrese en [www.installerinstitute.com](http://www.installerinstitute.com) o llame al 800-354-6782 para obtener más información y avance hacia un futuro mejor.



**Metra recomienda técnicos con certificación del Programa de Certificación en Electrónica Móvil (Mobile Electronics Certification Program, MECP).**