

# *Guide de montage d'un système de navigation et caméra dans une MITSUBISHI L200 CR MY10.*

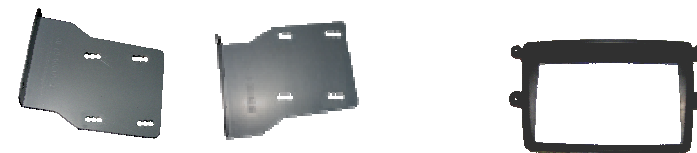

## **Pièces Pioneer**

**Kit 2 Din réf : CA-HM-MIT002**



**Interface électrique :**  
**réf : CA-R-MIT.002 chez PIONEER**

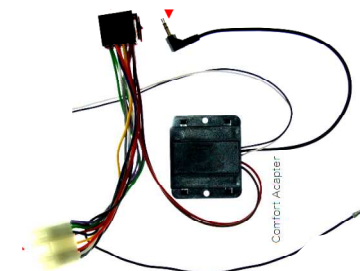

**Casquette chez Mitsubishi**  
**réf : MN179267XA**

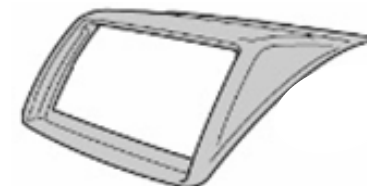

# *Dépose de l'autoradio d'origine*

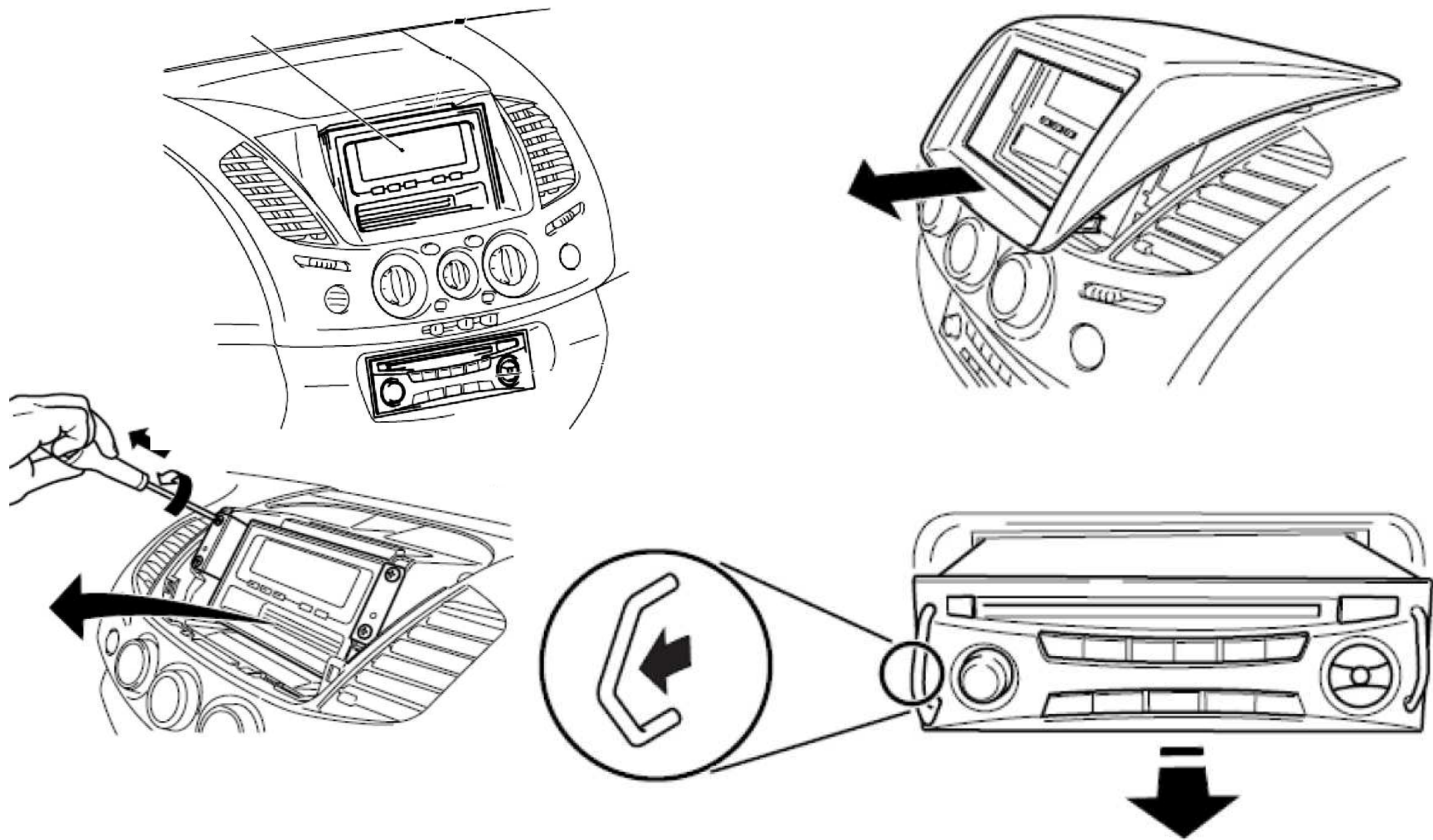



# *Installation du micro.*



*Passage du câble  
du micro*



# Connexion du fil marche arrière

**Signal marche arrière**  
*fil Rouge/Vert du faisceau avec le fil Violet/Blanc Pioneer*  
**REVERSE-GEAR SIGNAL INPUT**

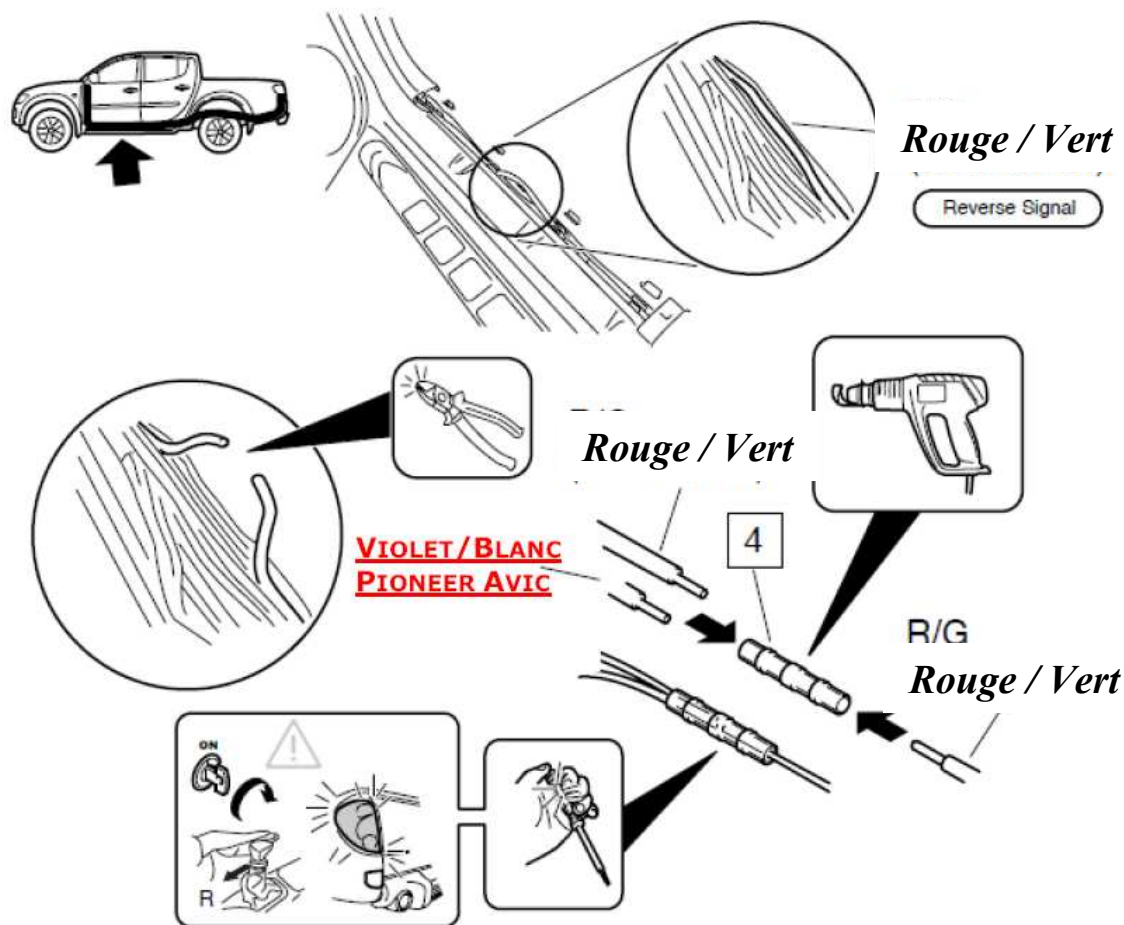
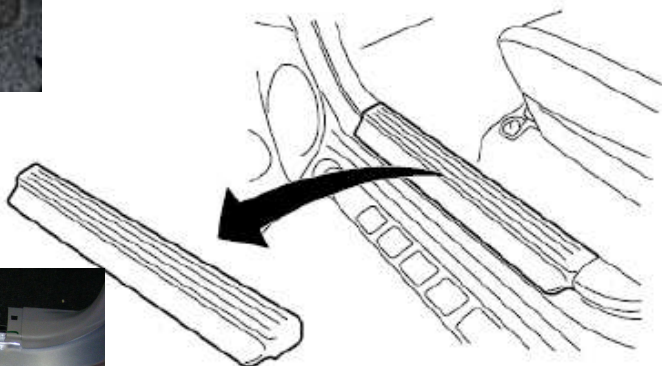
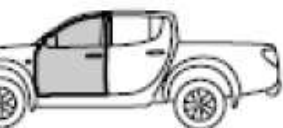



# Connexion du fil sécurité

## Signal sécurité

le fil Vert Pioneer **PARKING BRAKE**  
sur le fil **Jaune** du contacteur de frein à main

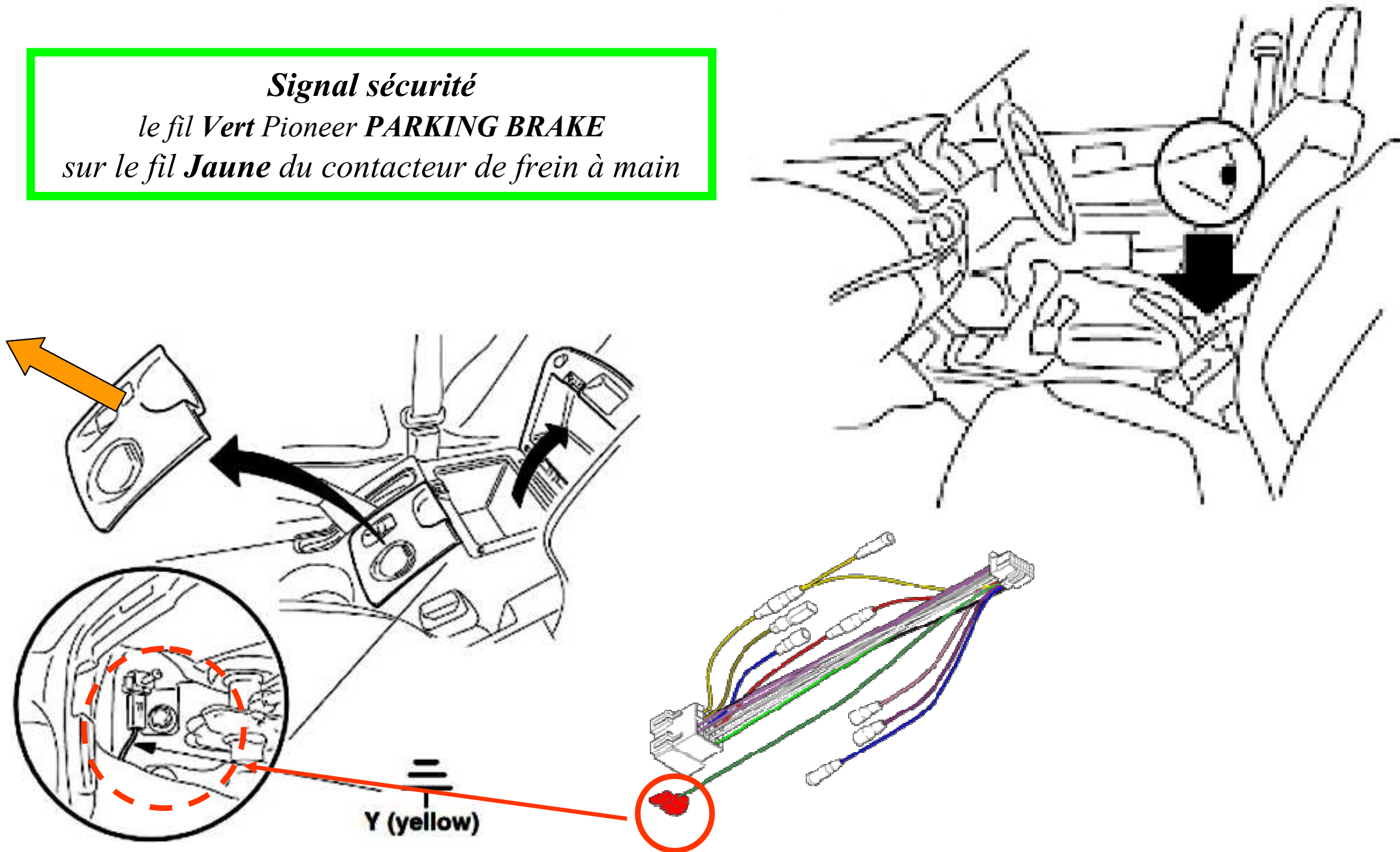

# Connexions des fils

Connecter le fil Rose Pioneer Signal de vitesse CAR SPEED SIGNAL INPUT en position 13 du connecteur C-127 couleur Blanc/ligne Bleu.

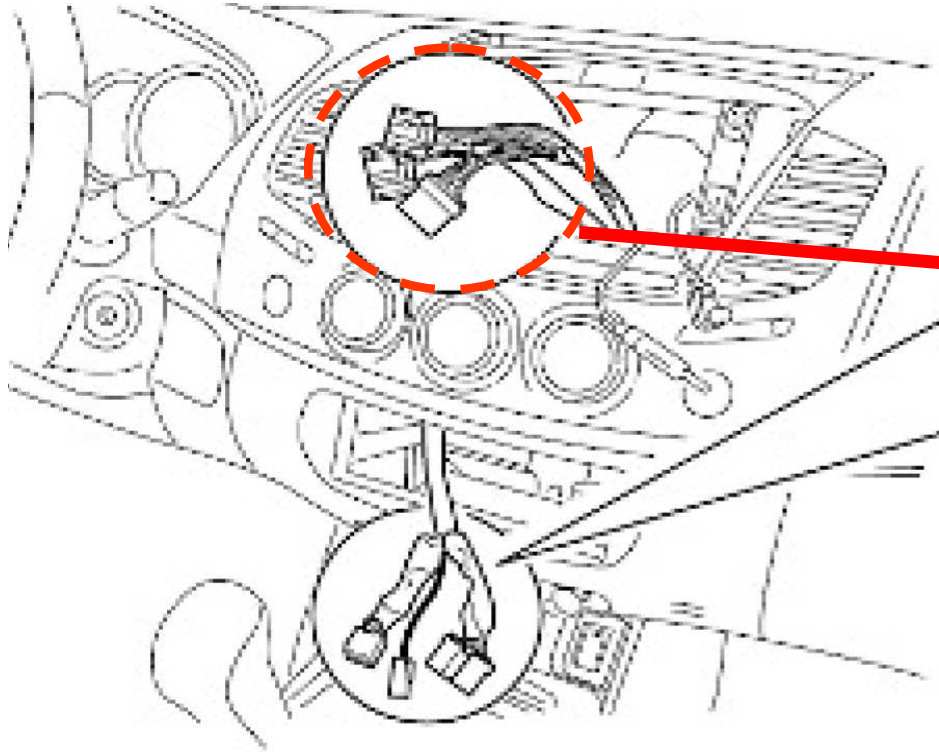

C-127

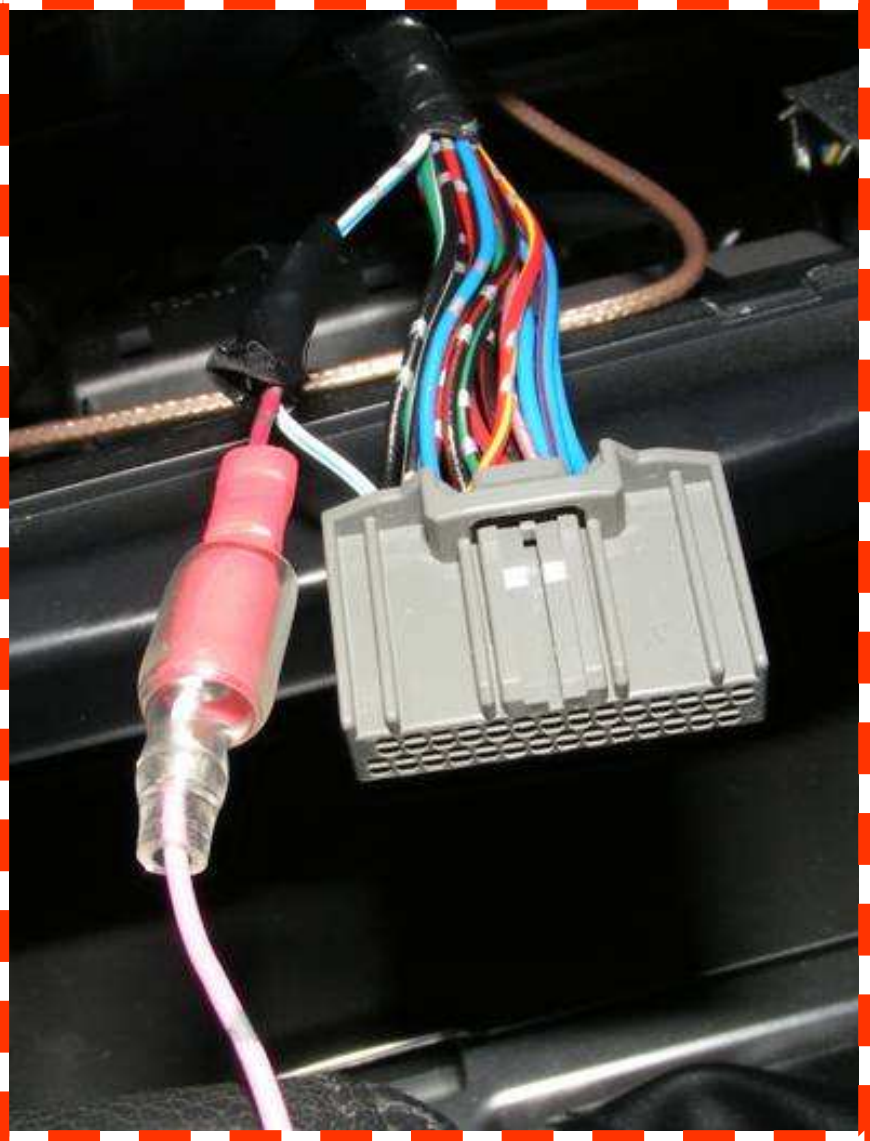
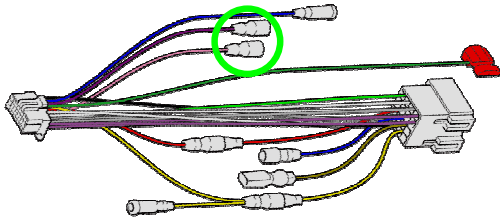
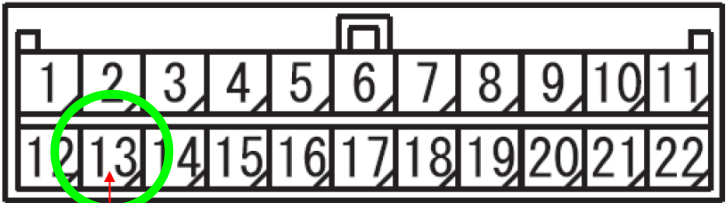

Signal de vitesse sur la position 13  
Couleur de câble: câble Blanc avec ligne bleue



# *Préparation des faisceaux*

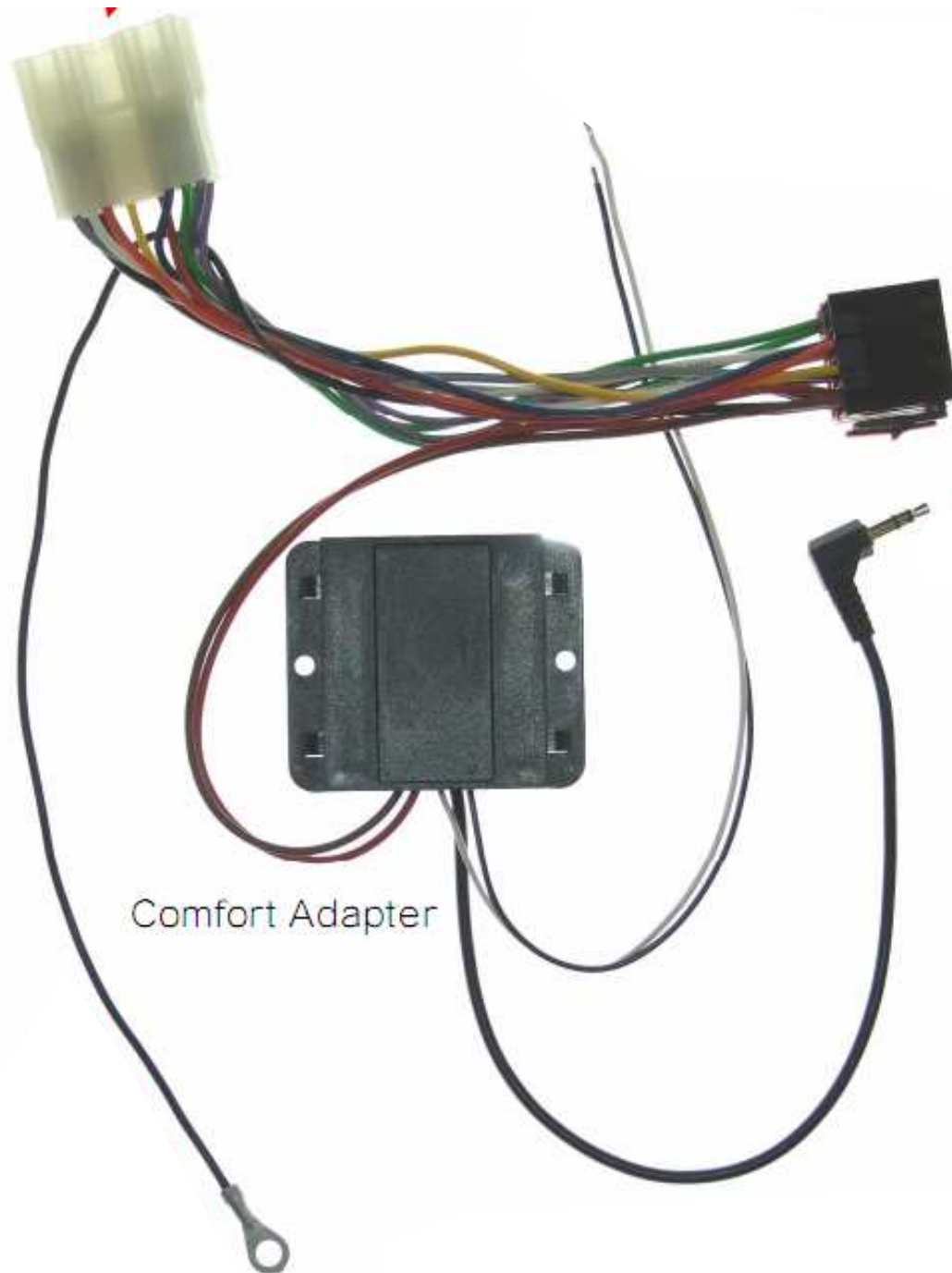

Comfort Adapter

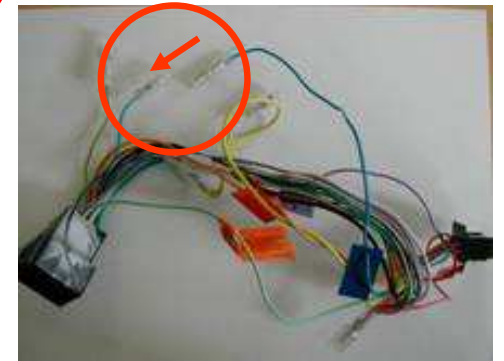

*Connecter les deux  
fils bleu ANTENNA  
CONTROL Pioneer  
ensemble.*

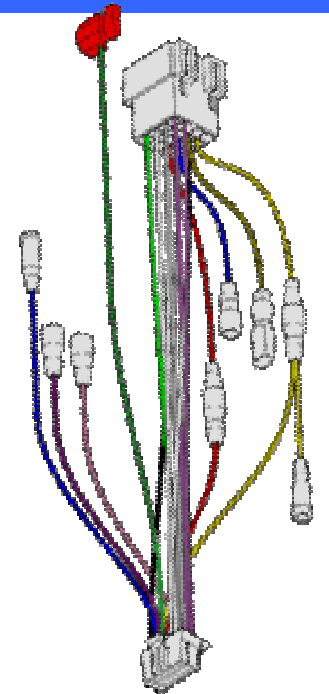



# Connexions des fils alimentations et multiplexage

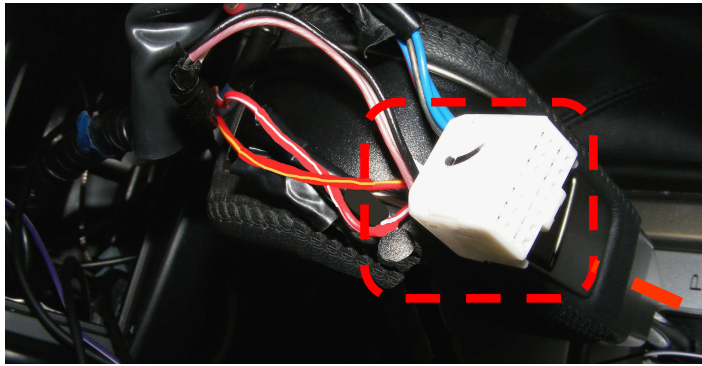
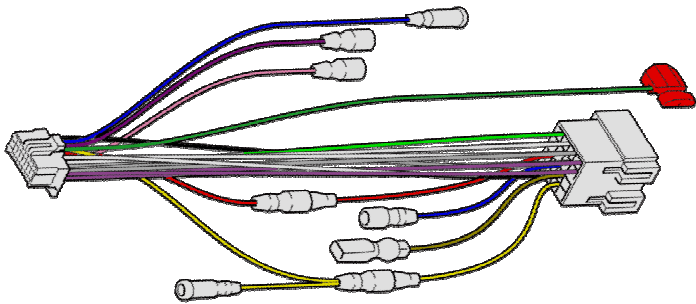

Couleur du câble sur la position 25 C-126: Rouge  
jaune



Couleur du câble sur la position 32 C-126: Rouge - ligne  
blanche

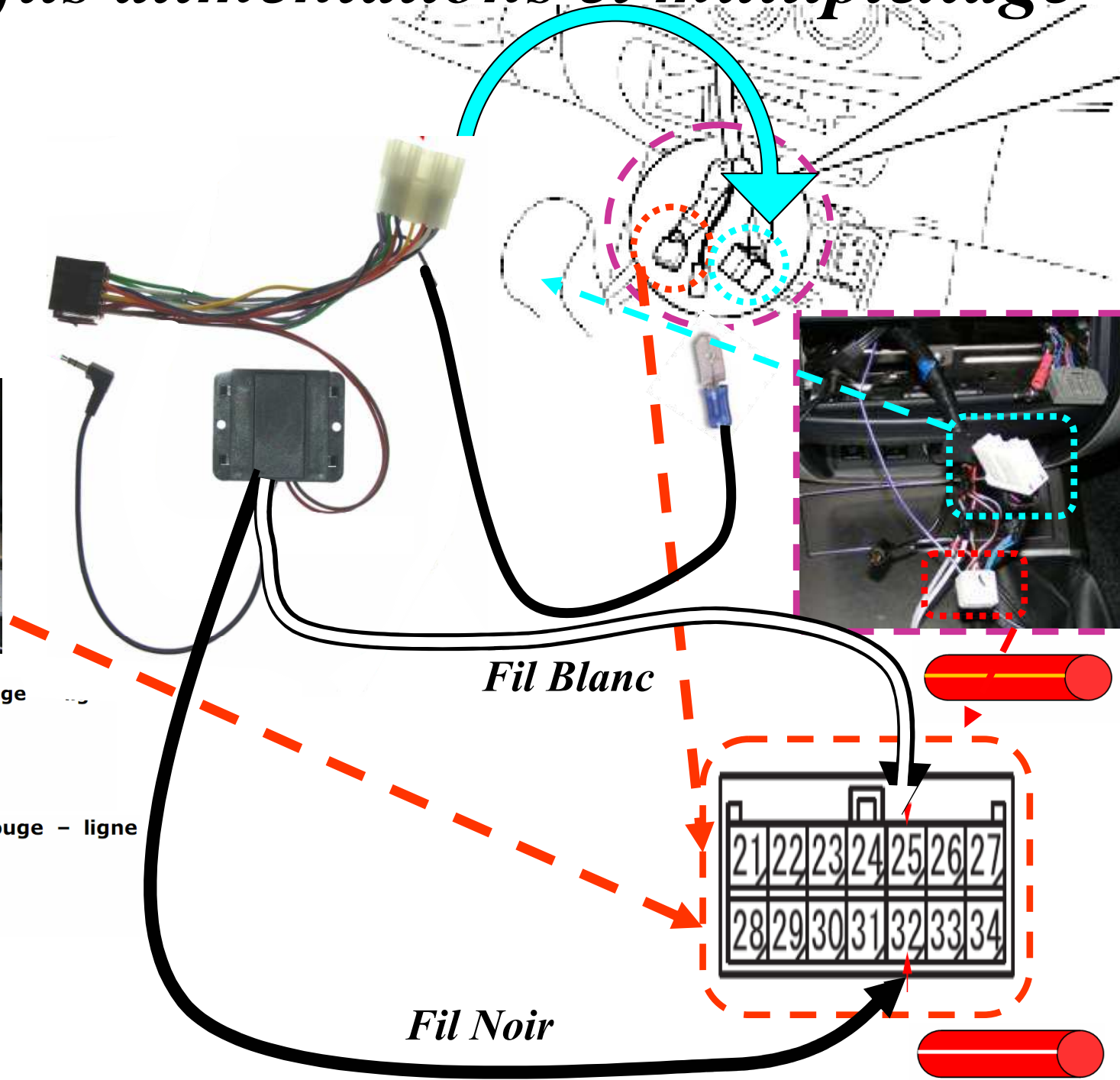



# Connexions des fils et de l'interface

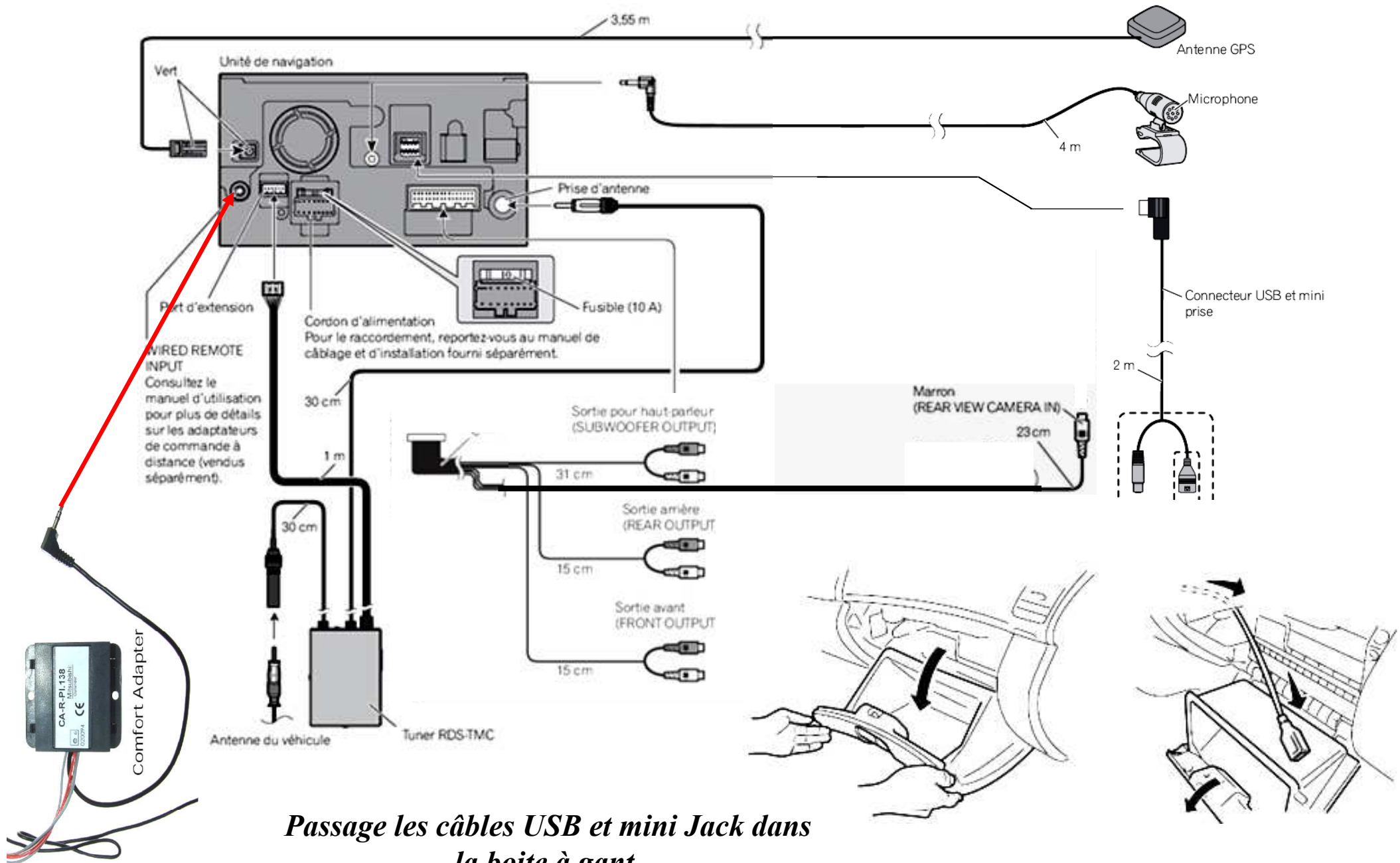

*Passage les câbles USB et mini Jack dans la boîte à gant.*

# *Préparation de l'autoradio.*



*Couper la zone rouge*

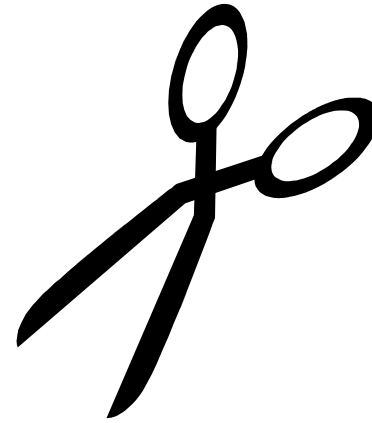

# *Préparation de l'autoradio.*





# *Fixation de l'autoradio.*

*Positionner la navigation fixer la avec les quatre vis.*

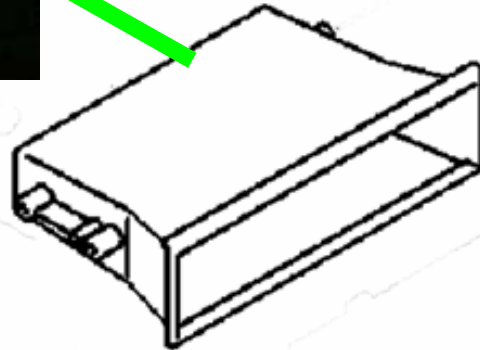

# *Installation de l'antenne GPS.*

*Poser l'antenne GPS sur la  
plaque métallique.*



# Remontage des caches

*Clipser la casquette plus le cadre sur l'ensemble navigation.*

