



INSTALLATION INSTRUCTIONS FOR PART 95-8202

APPLICATIONS

See application list inside

Toyota/Scion multi-kit 2000-up 95-8202

KIT FEATURES

- Double DIN radio provision



KIT COMPONENTS

- A) Double DIN trim plate

A

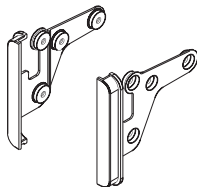

WIRING & ANTENNA CONNECTIONS (sold separately)

Wiring Harness:

- 70-1761 Toyota harness 1987-up
- 70-8113 Toyota harness 2000-2007
- TYT0-01 Toyota amp harness 2003-up

Antenna Adapter:

- Not required

TOOLS REQUIRED

- Cutting tool • Phillips screwdriver • Socket set
- Dremel/grinder tool

CAUTION: Metra recommends disconnecting the negative battery terminal before beginning any installation. All accessories, switches, and especially air bag indicator lights must be plugged in before reconnecting the battery or cycling the ignition.

Note: Refer to the instructions included with the aftermarket radio.

Applications

Toyota

Rav4.....	2001-2005
MR2 Spyder.....	2000-2005
Celica.....	2000-2005
Echo.....	2000-2005
Highlander <i>(without factory navigation)</i>	2001-2007
Matrix.....	2005-2008
Matrix <i>(with factory navigation)</i>	2009-2010
4 Runner <i>(excluding limited)</i>	2003-2009
Tundra.....	2003-2006
Sequoia.....	2003-2007
FJ Cruiser.....	2007-up
Yaris <i>(without power package)</i>	2007-2011
Yaris.....	2012-up

Scion

FR-S.....	2013-up
IQ.....	2012-up
TC.....	2005-up
XA.....	2004-2006
XB.....	2004-up
XD.....	2008-up

Subaru

BRZ.....	2013-up
Forester <i>(with SD based navigation)</i>	2009-up

Table of Contents

Dash Disassembly

– Scion XA 2004-2006.....	13
– Scion XB 2004-2006.....	14
– Scion XB 2008-up.....	14
– Scion TC 2005-2010.....	15
– Scion TC 2011-up.....	15
– Scion XD 2008-up.....	16
– Subaru BRZ 2013-up.....	17
– Subaru Forester 2009-up <i>(with SD based navigation)</i>	17
– Toyota Rav4 2001-2005.....	3
– Toyota MR2 Spyder 2000-2005.....	3
– Toyota Celica 2000-2005.....	4
– Toyota Echo 2000-2005.....	4
– Toyota Highlander 2001-2007 <i>(without factory navigation)</i> ...	5
– Toyota Matrix 2005-2008.....	5
– Toyota Matrix 2009-2010 <i>(with factory navigation)</i>	6
– Toyota 4 Runner 2003-2009 <i>(excluding limited)</i>	6-7
– Toyota Tundra 2003-2006.....	7-8
– Toyota Sequoia 2003-2007.....	8
– Toyota FJ Cruiser 2007-up.....	9
– Toyota Yaris 2007-2011 <i>(without power package)</i>	10
– Toyota Yaris 2012-up.....	11
– Scion FR-S 2013-up.....	11
– Scion IQ 2012-up.....	12

Kit Assembly

– Kit Preparation.....	18
– Double DIN radio provision.....	19

Toyota Rav4 2001-2005

1. Unclip and remove side panel from both sides of radio and climate controls. (Figure A)
2. Remove (4) Phillips screws securing the radio/climate control trim panel. (Figure B)
3. Remove (4) 10 mm bolts securing the radio. (Figure C)
4. Unplug and remove radio.
5. Remove factory brackets from radio. Retain brackets for use during kit assembly.

Continue to kit assembly

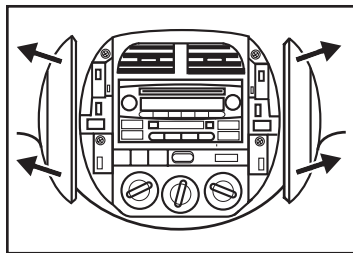

(Figure A)

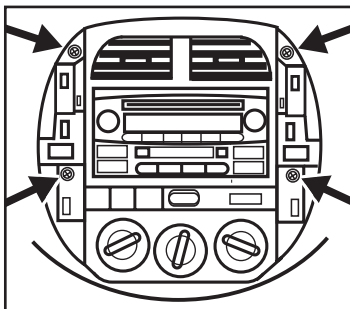

(Figure B)

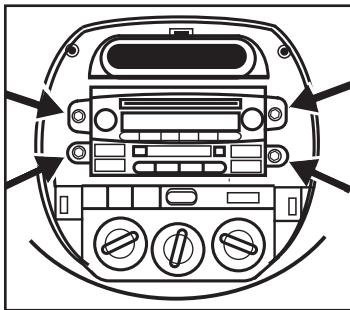

(Figure C)

Toyota MR2 Spyder 2000-2005

1. Unsnap the lower trim piece from each side of the dash console and remove (2) Phillips screws exposed in each cavity. Remove the upper trim piece from each side of the console. (Figure A)
2. Remove the climate control knobs and (2) Phillips screws exposed. Remove the climate control trim bezel. (Figure A)
3. Remove the ashtray and (1) 10mm bolt exposed. Unclip the ashtray trim bezel and remove. (Figure A)
4. Unclip the radio trim bezel, remove (4) Phillips screws securing the radio and disconnect the wiring.
5. Remove factory brackets from radio. Retain brackets for use during kit assembly.

Continue to kit assembly

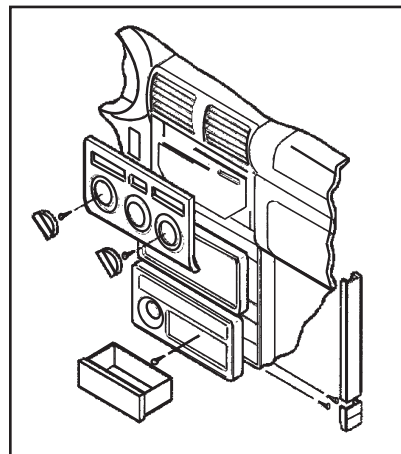

(Figure A)

Toyota Celica 2000-2005

1. Unclip and remove the gear shifter trim bezel and remove (2) Phillips screws exposed below the climate controls. (Figure A)
2. Pull off climate control knobs and remove (2) Phillips screws exposed. (Figure A)
3. Unclip the climate control/factory radio trim bezel and remove. (Figure A)
4. Remove (4) 10mm screws securing the factory radio and disconnect the wiring.
5. Remove factory brackets from radio. Retain brackets for use during kit assembly.

Continue to kit assembly

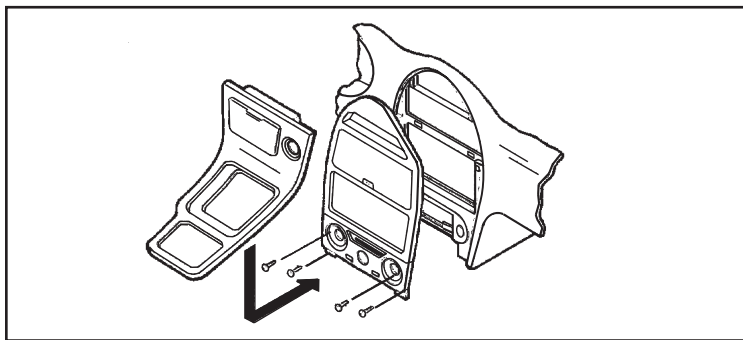

(Figure A)

Toyota Echo 2000-2005

1. Remove the climate control knobs and (2) Phillips screws exposed. Unclip and remove the climate control trim bezel. Depress the side clips securing the climate control panel and move the panel to access (2) Phillips screws from the top of the factory radio brackets. (Figure A)
2. Remove the ashtray. Unclip and remove the radio trim bezel. Remove (2) Phillips screws from the bottom of the radio brackets and disconnect the wiring.
3. Remove factory brackets from radio. Retain brackets for use during kit assembly.

Continue to kit assembly

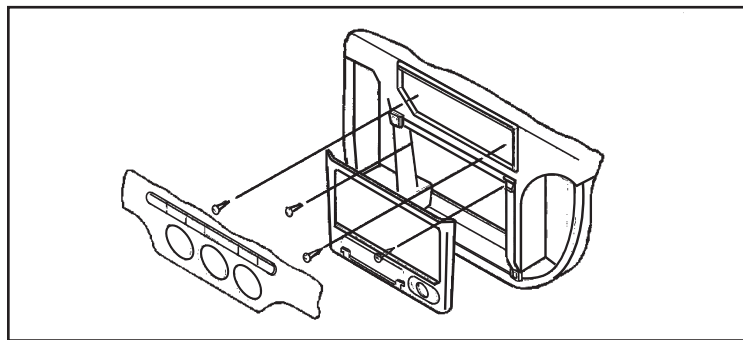

(Figure A)

Toyota Highlander 2001-2007

(without factory navigation)

1. Pull and remove dash panel from radio and climate controls. Tip: There are 8 clips. (Figure A)
2. Remove (6) 10mm bolts from radio and climate controls assembly. (Figure B)
3. Remove assembly and disconnect the wiring.
4. Remove (8) Phillips bolts and (4) Phillips screws to separate brackets from assembly. Retain brackets for use during kit assembly. (Figure C)

Continue to kit assembly

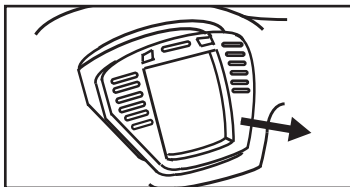

(Figure A)

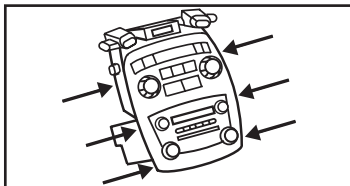

(Figure B)

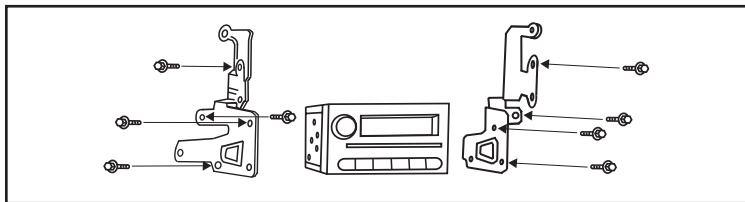

(Figure C)

Toyota Matrix 2005-2008

1. Unclip the bottom edge of the radio trim panel then lift up and out to remove. (Figure A)
2. Remove (4) 10mm bolts securing the factory radio. (Figure B)

Continue to kit assembly

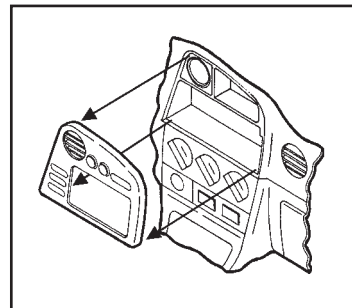

(Figure A)

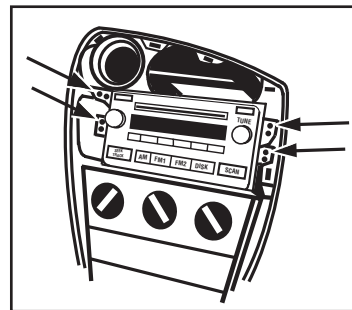

(Figure B)

Toyota Matrix 2009-2010 *(with factory navigation)*

1. Unclip and remove the radio trim panel including the A/C vent. (Figure A)
2. Remove (4) 10mm bolts securing the factory radio. Unplug and remove the radio. (Figure B)

Continue to kit assembly

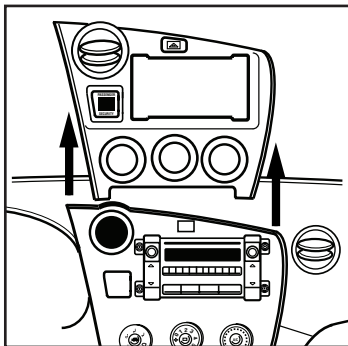

(Figure A)

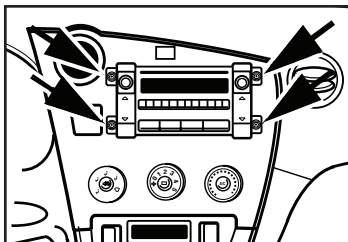

(Figure B)

Toyota 4 Runner 2003-2009 *(excluding limited)*

1. Unsnap and remove trim from around shifter.
2. Unsnap and remove trim covers from around center console pocket edge at front and rear of console.
3. Unsnap and remove center console cover. (Figure A)
4. Unsnap trim ring from around ignition key cylinder.
5. Remove (1) 10mm bolt from bottom right of panel below steering column. Unsnap panel and pull away to gain access behind panel. (Figure B)
6. Remove (1) 10mm bolt on bottom left of center panel behind panel below steering column. (Figure B)

Continued on next page

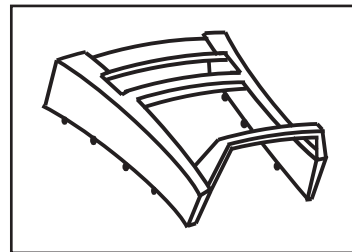

(Figure A)

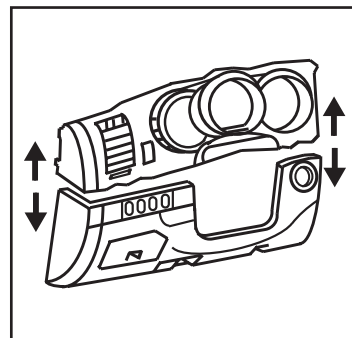

(Figure B)

Toyota 4 Runner 2003-2009 (excluding limited)

7. Remove (1) 10mm bolt beneath climate control behind pocket door. Unsnap and remove climate control. (Figure C)
8. Remove (2) 10mm bolts beneath radio behind climate controls.
9. Unsnap and remove entire center panel around radio. (Figure D)
10. Remove (2) 10mm bolts securing radio.
11. Unplug and remove radio.
12. Remove factory brackets from radio. Retain brackets for use during kit assembly.

Continue to kit assembly

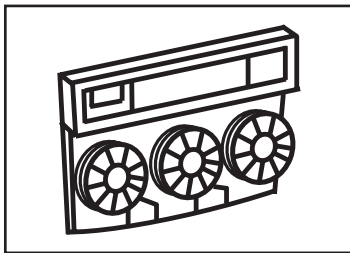

(Figure B)

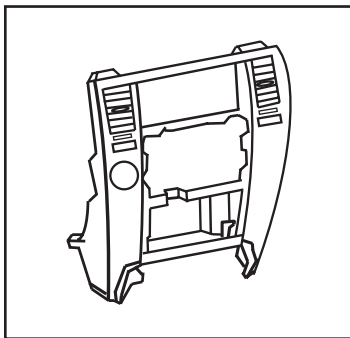

(Figure C)

Toyota Tundra 2003-2006

1. Remove the (3) climate control knobs by pulling straight outward. (Figure A)
2. Remove (3) Phillips screws from behind knobs. (Figure A)
3. Position vents facing upward and remove (1) Phillips screw from each A/C vent. (Figure B)

Continued on next page

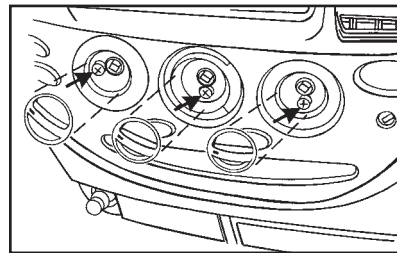

(Figure A)

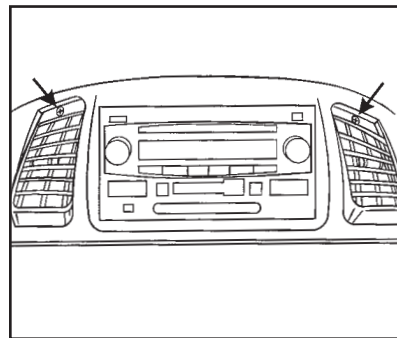

(Figure B)

Toyota Tundra 2003-2006

4. Unclip and remove entire trim panel. (Figure C)
5. Remove (4) 10mm bolts to remove radio. (Figure D)
6. Unplug and remove radio.
7. Remove factory brackets from radio. Retain brackets for use during kit assembly.

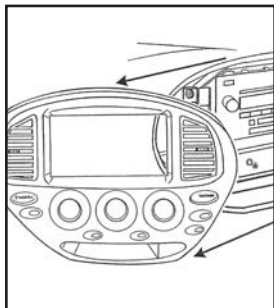
*(Figure C)*

Continue to kit assembly

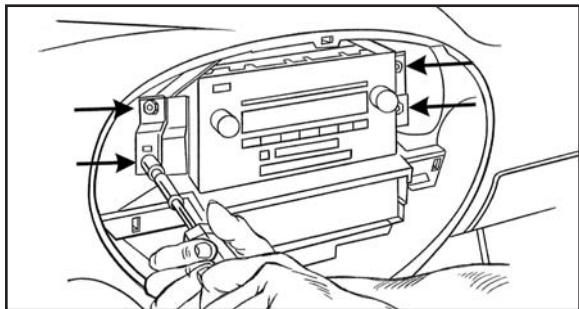
*(Figure D)***Toyota Sequoia 2003-2007**

1. Position vents facing upward and remove (1) Phillips screw from each A/C vent. (Figure A)
2. Unclip and remove entire radio trim panel including climate controls. (Figure B)
3. Remove (4) 10mm bolts to remove radio. (Figure C)
4. Unplug and remove radio.
5. Remove factory brackets from radio. Retain brackets for use during kit assembly.

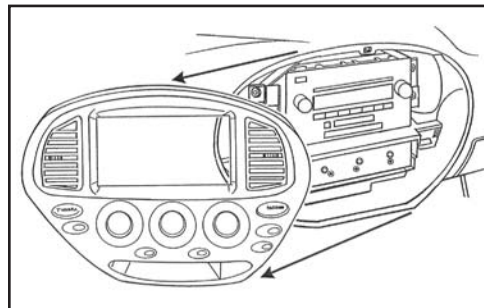
*(Figure B)*

Continue to kit assembly

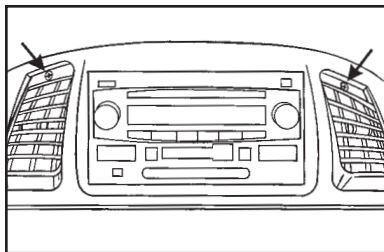
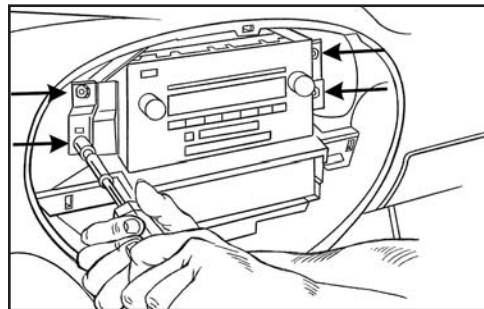
*(Figure A)**(Figure C)*

Toyota FJ Cruiser 2007-up

1. Remove two Phillips screws from bottom part of side trim panels. (Figure A)
2. Using a panel removal tool, carefully remove the side trim panels. (Figure B)
3. Remove (2) Phillips screws from radio trim panel. (Figure C)
4. Using panel removal tool, carefully remove radio trim panel. (Figure D)
5. Remove (4) 10mm bolts securing the radio.
6. Unplug and remove radio.
7. Remove factory brackets from radio. Retain brackets for use during kit assembly.

Continue to kit assembly

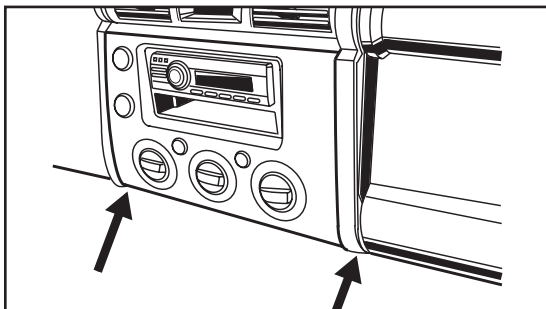

(Figure A)

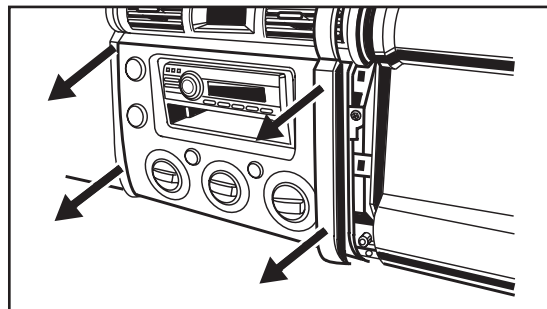

(Figure B)

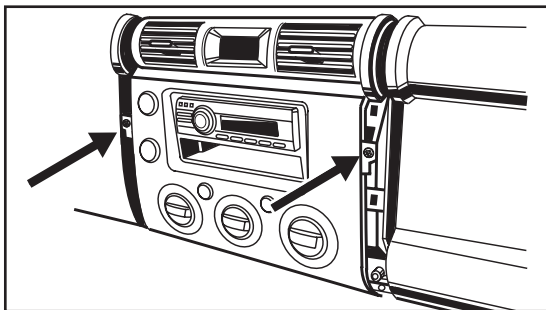

(Figure C)

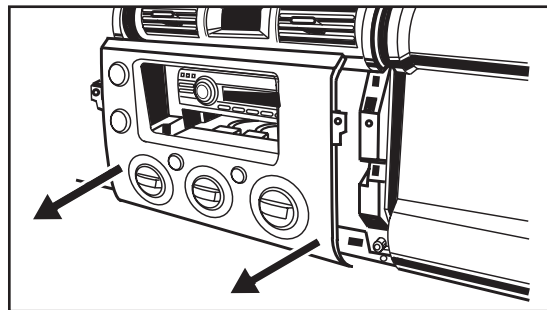

(Figure D)

Yaris 2007-2011 (without power package)

1. Unclip the bottom trim panel located underneath the A/C controls. (Figure A)
2. Unclip the two side trim panels that surround the A/C controls and radio. (Figure A)
3. Unclip the Instrument trim Panel surrounding the speedometer and gauges. (Figure B)
4. Unclip the radio/AC vents trim panel. (Figure B)
5. Remove (4) Phillips screws securing radio. (Figure C)
6. Unplug and remove radio.
7. Remove (4) Phillips screws securing factory brackets on each side of the radio and remove brackets. Retain brackets for use during kit assembly. (Figure D)

Continue to kit assembly

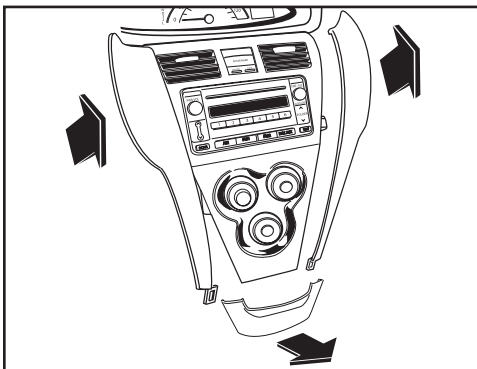

(Figure A)

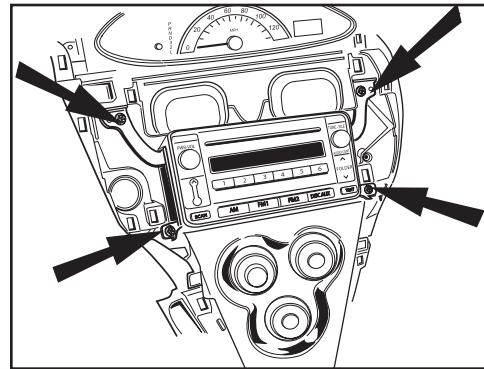

(Figure C)

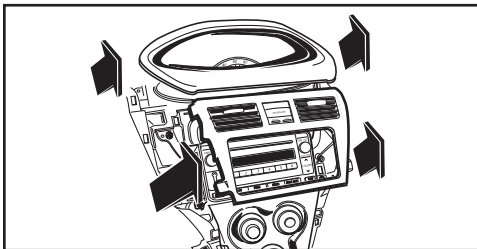

(Figure B)

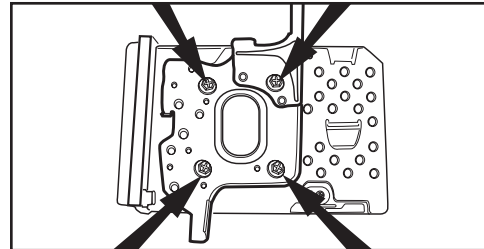

(Figure D)

Yaris 2012-up

1. Unclip and remove entire panel including A/C vent on passenger side of dash. (Figure A)
2. Unclip and remove the panel from around the radio. (Figure B)
3. Remove four 10 mm bolts and remove factory radio. (Figure C)

Continue to kit assembly

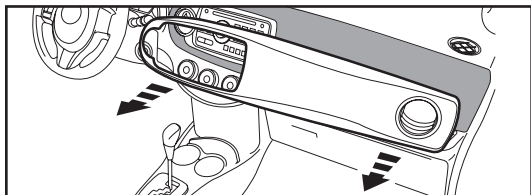

(Figure A)

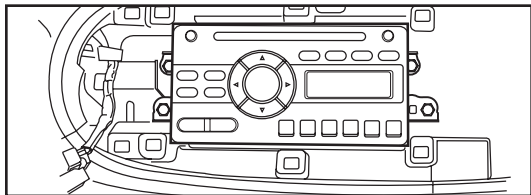

(Figure B)

Scion FR-S 2013-up

1. Unclip and remove the panel from around the radio. (Figure A)
2. Remove four 10 mm bolts and remove factory radio. (Figure B)

Continue to kit assembly

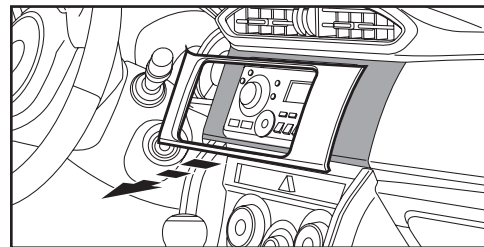

(Figure A)

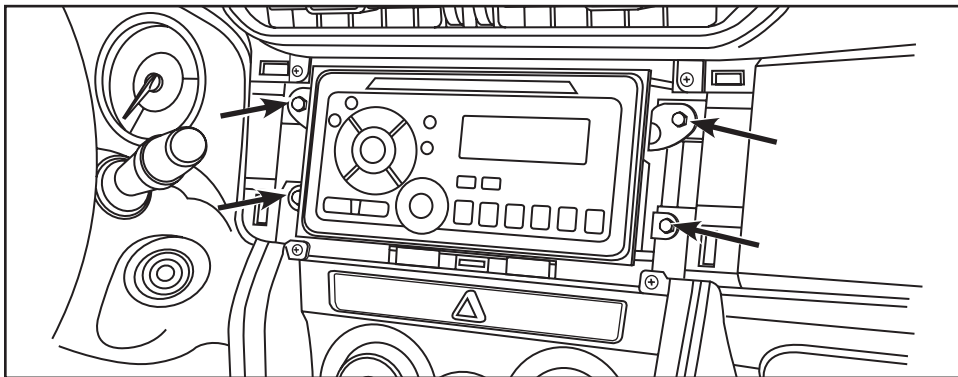

(Figure B)

Scion IQ 2012-up

1. Unclip and remove the climate control panel. (Figure A)
2. Unclip and remove the panel from around the radio. (Figure B)
3. Remove four 10 mm bolts and remove factory radio. (Figure C)

Continue to kit assembly

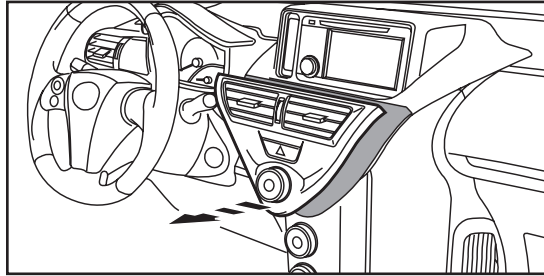

(Figure A)

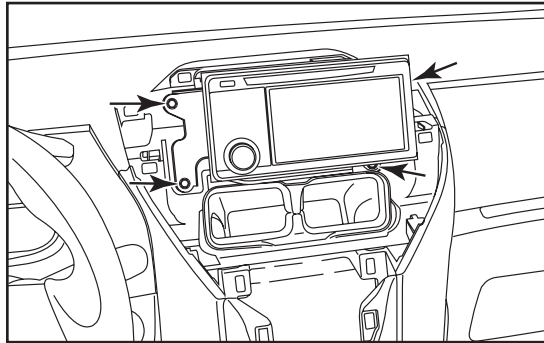

(Figure C)

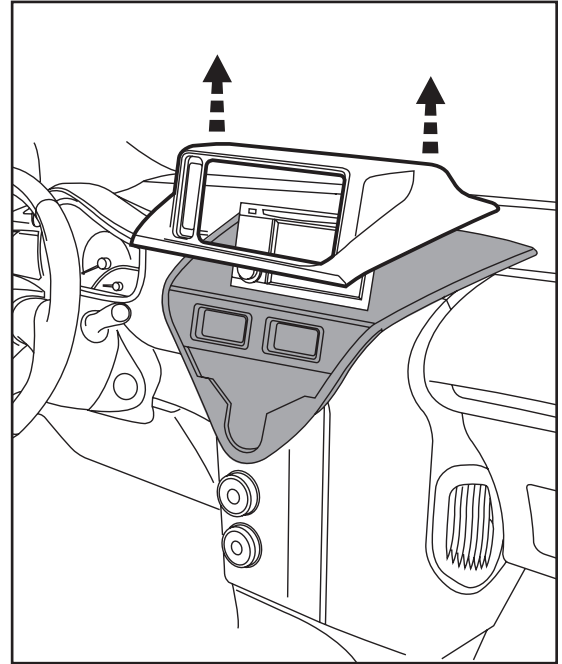

(Figure B)

Scion XA 2004-2006

1. Pull outward on the (3) climate control knobs and remove. (Figure A)
2. Remove (2) Phillips screws from behind the outer two climate knobs. (Figure B)
3. Unsnap and remove the trim pieces on each side of the climate control/ashtray/pocket assembly. (Figure C)
4. Remove (2) Phillips screws from the bottom of the climate control/radio trim panel and unsnap and remove the entire panel. (Figure D)
5. Remove (4) Phillips screws to remove the factory radio.
6. Remove factory brackets from radio. Retain brackets for use during kit assembly.

Continue to kit assembly

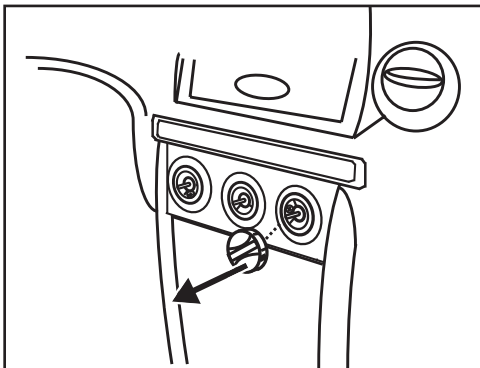

(Figure A)

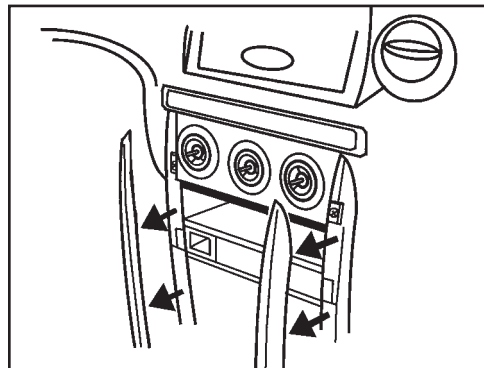

(Figure C)

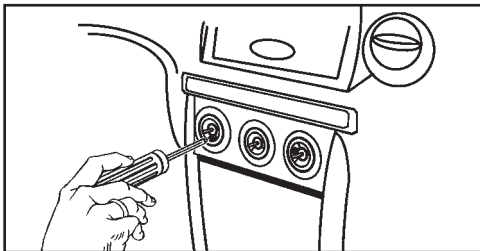

(Figure B)

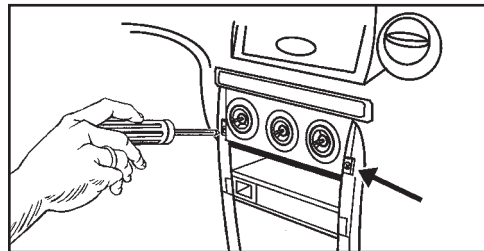

(Figure D)

Scion XB 2004-2006

1. Pull outward on the (3) climate control knobs and remove. (Figure A)
2. Remove (2) Phillips screws from behind the outer (2) knobs. (Figure B)
3. Unsnap and remove the entire panel surrounding the climate controls and the radio. (Figure C)
4. Remove (4) Phillips screws to remove the factory radio.
5. Remove factory brackets from radio. Retain brackets for use during kit assembly.

Continue to kit assembly

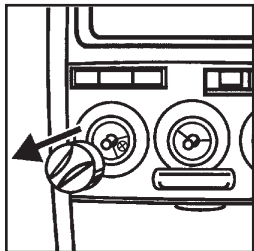

(Figure A)

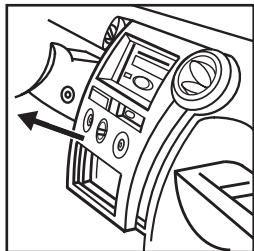

(Figure B)

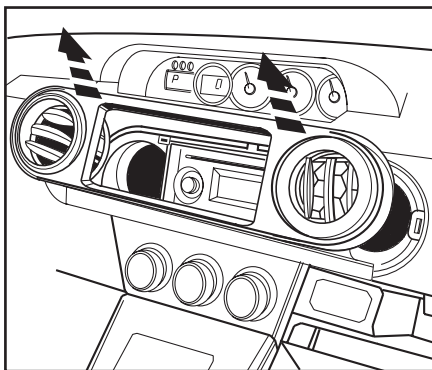

(Figure A)

Scion XB 2008-up

1. Unclip and remove the trim panel around the radio including the A/C vents. (Figure A)
2. Unclip and remove the trim panel at the bottom edge of the dash cavity. (Figure B)
3. Remove (4) 10mm bolts securing the radio. (Figure C)

Continue to kit assembly

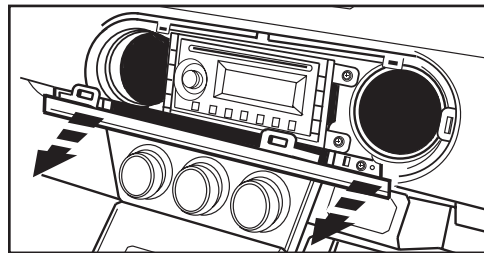

(Figure B)

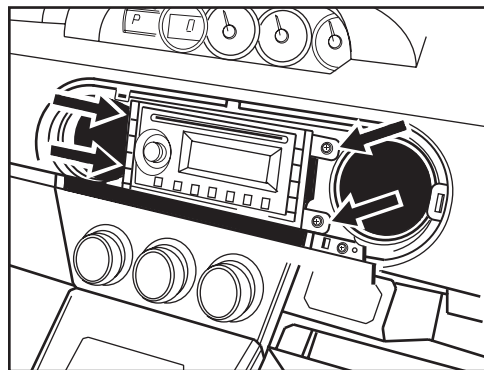

(Figure C)

Scion TC 2005-2010

1. Unsnap trim from around shifter (not necessary to be removed). (Figure A)
2. Unclip and remove panel from around radio (including climate controls and radio door). (Figure B)
3. Remove (2) 10mm nuts from the top mounting locations and (2) 10mm bolts from the bottom mounting locations to remove the radio. (Figure C)
4. Remove factory brackets from radio. Retain brackets for use during kit assembly.

Continue to kit assembly

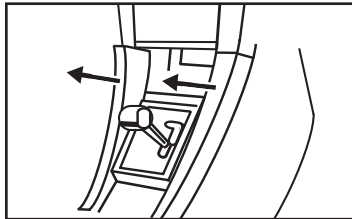

(Figure A)

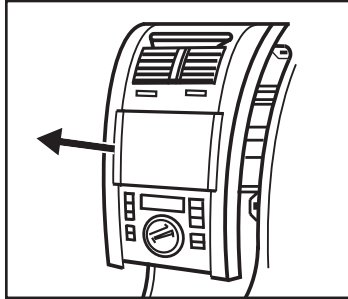

(Figure B)

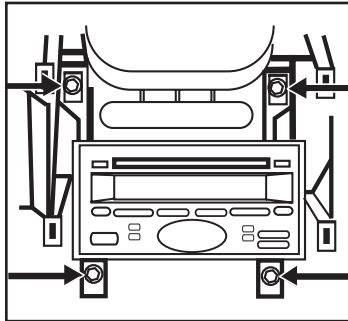

(Figure C)

Scion TC 2011-up

1. Unclip and remove the radio trim panel. (Figure A)
2. Remove (4) 10mm bolts securing the radio. (Figure B)
3. Remove factory brackets from radio. Retain brackets for use during kit assembly.

Continue to kit assembly

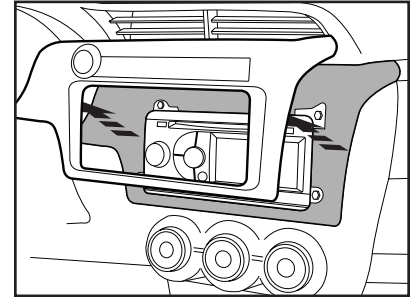

(Figure A)

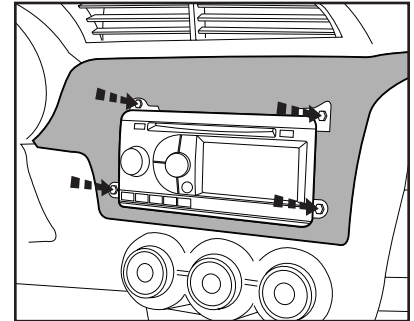

(Figure B)

Scion XD 2008-up

1. Unclip radio trim panel. Unplug and remove panel. (Figure A)
2. Remove (4) Phillips screws securing the radio. Unplug and remove radio. (Figure B)
3. Remove factory brackets from radio. Retain brackets for use during kit assembly. (Figure C)

Continue to kit assembly

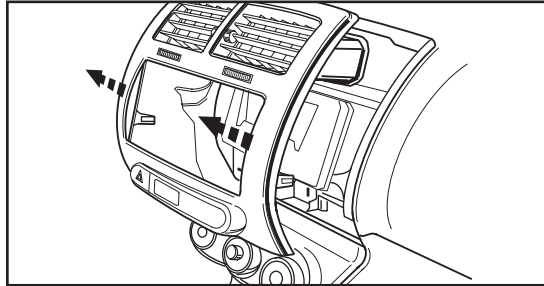

(Figure A)

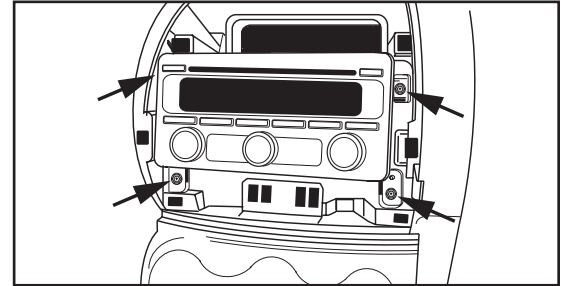

(Figure B)

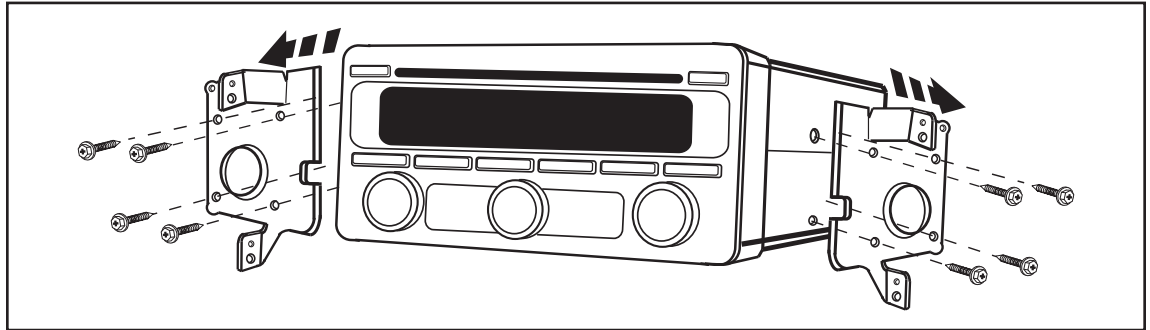

(Figure C)

Subaru BRZ 2013-up

1. Unclip and remove the panel from around the radio. (Figure A)
2. Remove four 10 mm bolts and remove factory radio. (Figure B)

Continue to kit assembly

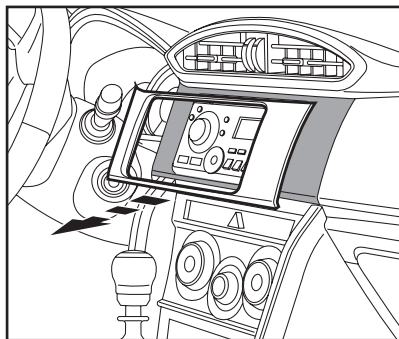

(Figure A)

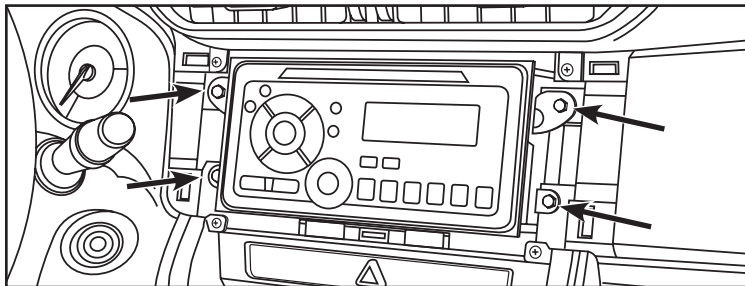

(Figure B)

**Subaru Forester (with SD based navigation)
2009-up**

1. Unclip and remove the trim panel surrounding the factory radio including the A/C vents. (Figure A)
2. Remove (4) Phillips screws securing the radio. Unplug and remove the radio. (Figure B)

Continue to kit assembly

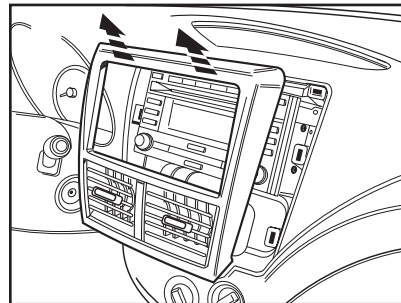

(Figure A)

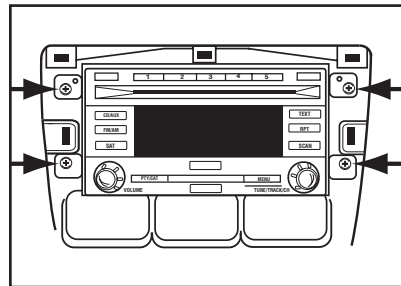

(Figure B)



Kit Assembly 95-8202

Kit Preparation

For the Scion TC (both generations) and XA:

Cut off the front upper section of the double DIN trim plates, as shown by the dotted lines labeled "A" in. (Figure A)

For the 2001-2005 Toyota Rav4, 2001-2007 Toyota Highlander (without factory navigation), 2003-2006 Toyota Tundra and 2003-2007 Toyota Sequoia:

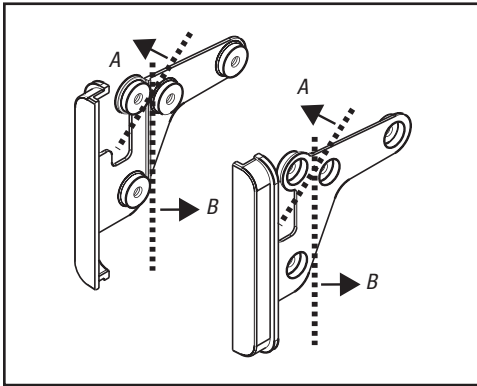

(Figure A)

Cut off the rear section of the double DIN trim plates, as shown by the dotted lines labeled "B" in. (Figure A)

For the 2013-up Scion FR-S and Subaru BRZ:

Cut the double DIN trim plate as shown in. (Figure B)

Note: Care must be taken to cut this. A Dremel tool and a steady hand must be used. If the bracket is

damaged you can still use it by using the single screw hole leftover. If you do go this route, you will have to brace up the rear of the radio to prevent it from dropping down. (Figure B)

For all other vehicles skip to Step 1.

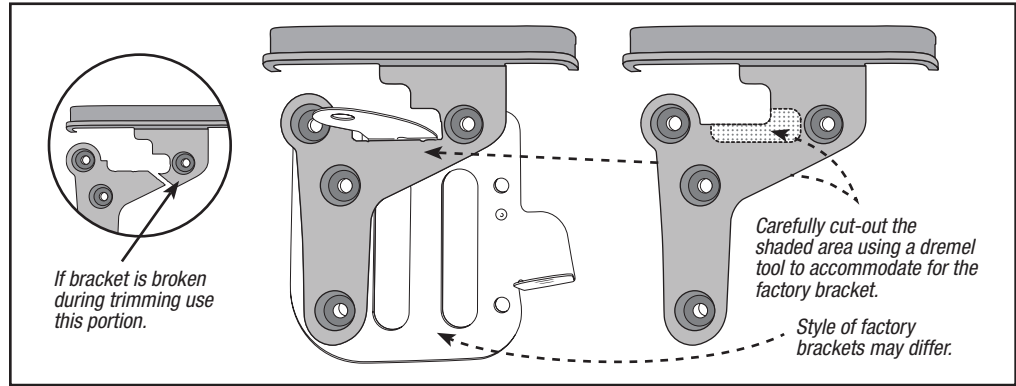

(Figure B)

Double DIN radio provision

1. Attach the factory mounting brackets and the 95-8202 double DIN trim plates to the double DIN radio with the screws supplied with the radio. (Figure B)

Note: Remove locating pins from factory brackets using a grinder tool.

2. Locate the factory wiring harness in the dash. Metra recommends using the proper mating adapter from Metra or AXXESS. Re-connect the negative battery terminal and test the radio for proper operation.
3. Reassemble dash in reverse order of disassembly.

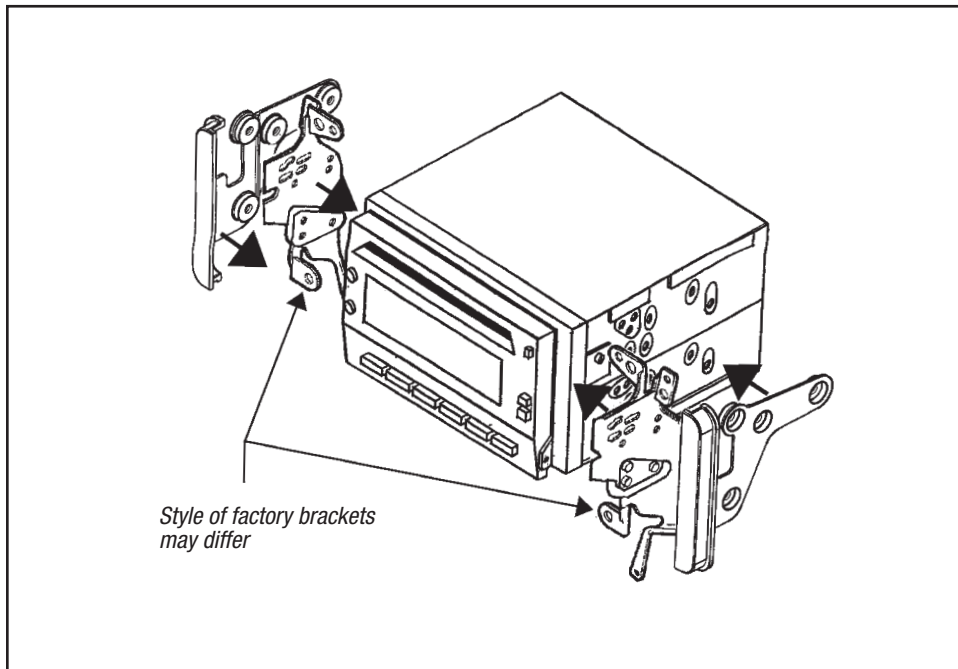

(Figure A)



INSTALLATION INSTRUCTIONS FOR PART 95-8202



REV. 7/9/2014 INST95-8202



KNOWLEDGE IS POWER

Enhance your installation and fabrication skills by enrolling in the most recognized and respected mobile electronics school in our industry. Log onto www.installerinstitute.com or call 800-354-6782 for more information and take steps toward a better tomorrow.



Metra recommends MECP certified technicians



INSTRUCCIONES DE INSTALACIÓN PARA LA PIEZA 95-8202

APLICACIONES

Ver el interior de la cubierta delantera

Toyota/Scion multi-kit 2000 y mas 95-8202

CARACTERÍSTICAS DEL KIT

- Provisión de radio doble DIN



COMPONENTES DEL KIT

- A) Placa de moldura doble DIN

A

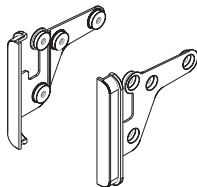

CABLEADO Y CONEXIONES DE ANTENA

Arnés de cableado: (se venden por separado)

- Arnés 70-1761 para Toyota 1987 y más recientes
- Arnés 70-8113 para Toyota 1987 y más recientes
- TYT0-01 - Arnés para amplificador para Toyota 2003 y más recientes

Adaptador de antena:

- No se requiere

HERRAMIENTAS REQUERIDAS

- Herramienta de corte • Destornillador Phillips
- Juego de dados • Rectificadora

PRECAUCIÓN: Metra recomienda desconectar el terminal negativo de la batería antes de comenzar cualquier instalación. Todos los accesorios, interruptores y, especialmente, las luces indicadoras de airbag deben estar enchufados antes de volver a conectar la batería o comenzar el ciclo de ignición.

NOTA: Remítase a las instrucciones incluidas con el radio de postventa.

Aplicaciones

Toyota

Rav4.....	2001-2005
MR2 Spyder.....	2000-2005
Celica.....	2000-2005
Echo.....	2000-2005
Highlander (<i>sin navegación de fábrica</i>).....	2001-2007
Matrix.....	2005-2008
Matrix (<i>con navegación de fábrica</i>).....	2009-2010
4 Runner (<i>excluyendo limited</i>).....	2003-2009
Tundra.....	2003-2006
Sequoia.....	2003-2007
FJ Cruiser.....	2007 y mas
Yaris (<i>sin power package</i>).....	2007-2011
Yaris.....	2012 y mas

Scion

FR-S.....	2013 y mas
IQ.....	2012 y mas
TC.....	2005 y mas
XA.....	2004-2006
XB.....	2004 y mas
XD.....	2008 y mas

Subaru

BRZ.....	2013 y mas
Forester (<i>con navegación basada en SD</i>).....	2009 y mas

Indice

Desmontaje del tablero

– Toyota Rav4 2001-2005.....	3
– Toyota MR2 Spyder 2000-2005.....	3
– Toyota Celica 2000-2005.....	4
– Toyota Echo 2000-2005.....	4
– Toyota Highlander 2001-2007 (<i>sin navegación de fábrica</i>)....	5
– Toyota Matrix 2005-2008.....	5
– Toyota Matrix 2009-2010 (<i>con navegación de fábrica</i>).....	6
– Toyota 4 Runner 2003-2009 (<i>excluyendo limited</i>).....	6-7
– Toyota Tundra 2003-2006.....	7-8
– Toyota Sequoia 2003-2007.....	8
– Toyota FJ Cruiser 2007 y mas.....	9
– Toyota Yaris 2007-2011 (<i>sin paquete de energía</i>).....	10
– Toyota Yaris 2012 y mas.....	11
– Scion FR-S 2013 y mas.....	11
– Scion IQ 2012 y mas.....	12
– Scion XA 2004-2006.....	13
– Scion XB 2004-2006.....	14
– Scion XB 2008 y mas.....	14
– Scion TC 2005-2010.....	15
– Scion TC 2011 y mas.....	15
– Scion XD 2008 y mas.....	16
– Subaru BRZ 2013 y mas.....	17
– Subaru Forester 2009 y mas (<i>con navegación basada en SD</i>)..	17

Ensamble del kit

– Preparación del kit.....	18
– Provisión de radio doble DIN.....	19

Toyota Rav4 2001-2005

1. Desenganche y quite el panel lateral de ambos lados del radio y los controles del clima. (Figura A)
2. Quite los (4) tornillos Phillips que sujetan el panel de la moldura del radio/control de clima. (Figura B)
3. Quite los (4) pernos de 10 mm que sostienen el radio. (Figura C)
4. Desconecte y retire el radio.
5. Quite los soportes de fábrica del radio. Guarde los soportes para usarlos al ensamblar el kit.

Continuará al ensamble del kit

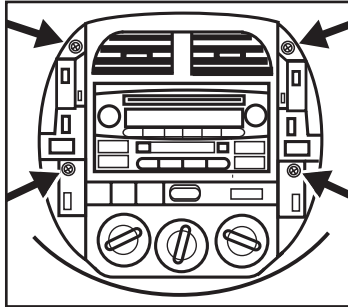

(Figura B)

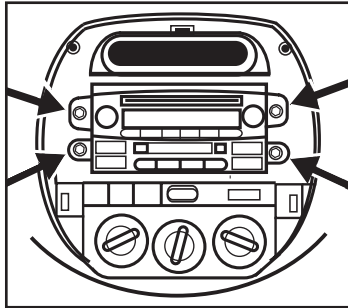

(Figura C)

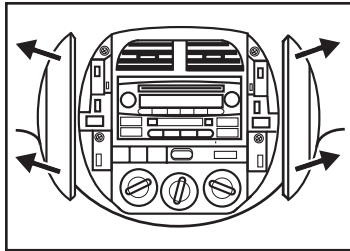

(Figura A)

Toyota MR2 Spyder 2000-2005

1. Desenganche la pieza de moldura inferior de cada lado de la consola del tablero y quite los (2) tornillos Phillips que quedan a la vista en cada cavidad. Quite la pieza de moldura superior de cada lado de la consola. (Figura A)
2. Quite las perillas de control de clima y los (2) tornillos Phillips que quedan a la vista. Quite el bisel de la moldura del control de clima. (Figura A)
3. Quite el cenicero y (1) perno expuesto. Desenganche el bisel de la moldura del cenicero y quítelo. (Figura A)
4. Desenganche el bisel de la moldura del radio, quite los (4) tornillos Phillips que sujetan la unidad y desconecte el cableado.
5. Quite los soportes de fábrica del radio. Guarde los soportes para usarlos al ensamblar el kit.

Continuará al ensamble del kit

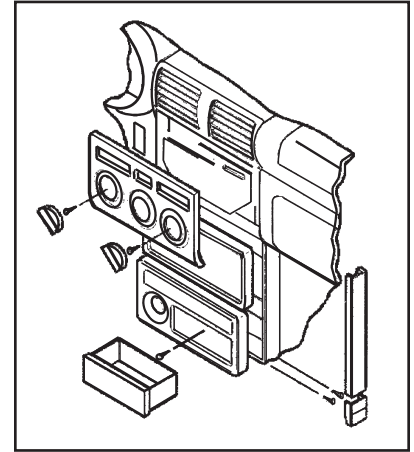

(Figura A)

Toyota Celica 2000-2005

1. Desenganche y quite el bisel de la moldura de la palanca de velocidades y quite los (2) tornillos Phillips expuestos debajo de los controles del clima. (Figura A)
2. Quite las perillas de control de clima y los (2) tornillos Phillips que quedan a la vista. (Figura A)
3. Desenganche el bisel del control de clima/moldura del radio de fábrica y quite. (Figura A)
4. Quite los (4) tornillos de 10 mm que sujetan el radio de fábrica y desconecte el cableado.
5. Quite los soportes de fábrica del radio. Guarde los soportes para usarlos al ensamblar el kit.

Continuará al ensamble del kit

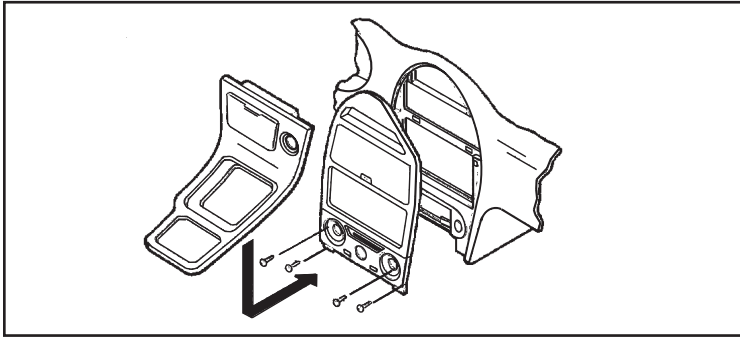

(Figura A)

Toyota Echo 2000-2005

1. Quite las perillas de control de clima y los (2) tornillos Phillips que quedan a la vista. Desenganche y quite el bisel de la moldura del control de clima. Presione los ganchos laterales que sujetan el panel del control de clima y mueva el panel para acceder los (2) tornillos Phillips desde la parte superior de los soportes del radio de fábrica. (Figura A)
2. Quite el cenicero. Desenganche y quite el bisel de la moldura del radio. Quite los (2) tornillos Phillips de la parte inferior de los soportes del radio y desconecte el cableado.
3. Quite los soportes de fábrica del radio. Guarde los soportes para usarlos al ensamblar el kit.

Continuará al ensamble del kit

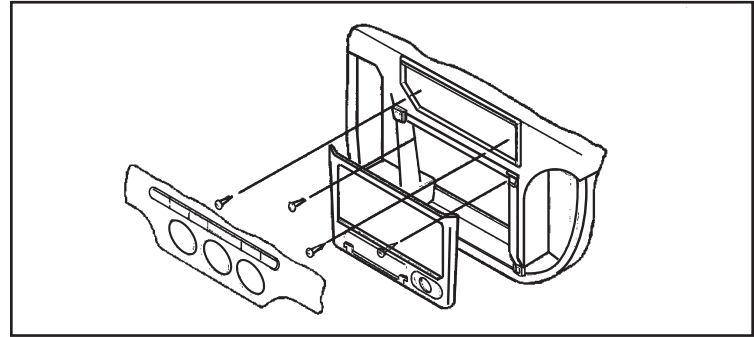

(Figura A)

Toyota Highlander 2001-2007

(sin navegación de fábrica)

1. Jale y quite el panel del tablero del radio y los controles del clima. Sugerencia: Hay 8 ganchos. (Figura A)
2. Quite los (6) pernos de 10mm de los controles del radio y clima. (Figura B)
3. Quite el ensamble y desconecte el cableado.
4. Quite los (8) pernos Phillips y los (4) tornillos Phillips para separar los soportes del ensamble. Guarde los soportes para usarlos al ensamblar el kit. (Figura C)

Continuará al ensamble del kit

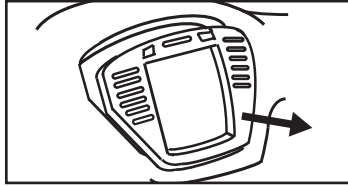

(Figura A)

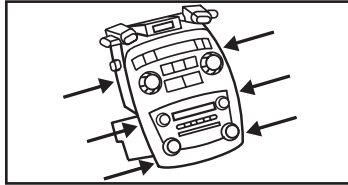

(Figura B)

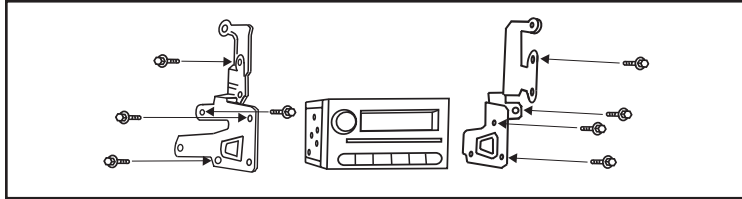

(Figura C)

Toyota Matrix 2005-2008

1. Desenganche el borde inferior del panel de la moldura del radio y luego levante y retire. (Figura A)
2. Quite los (4) pernos de 10 mm que sujetan el radio de fábrica. (Figura B)

Continuará al ensamble del kit

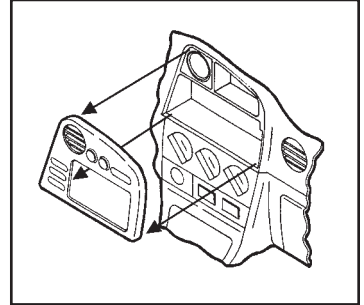

(Figura A)

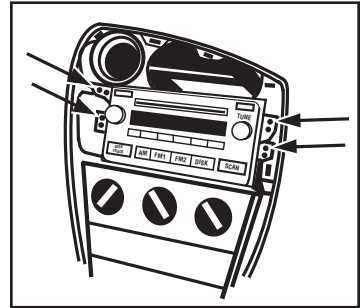

(Figura B)

Toyota Matrix 2009-2010 (con navegación de fábrica)

1. Desenganche el borde inferior del panel de la moldura del radio y luego levante y retire. (Figura A)
2. Quite los (4) pernos de 10 mm que sujetan el radio de fábrica. (Figura B)

Continuará al ensamble del kit

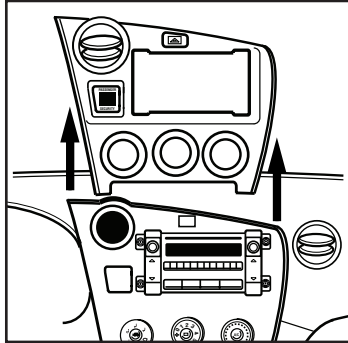

(Figura A)

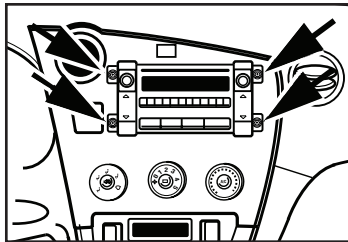

(Figura B)

Toyota 4 Runner 2003-2009 (excluyendo limited)

1. Suelte a presión y retire la moldura de alrededor de la palanca de velocidades.
2. Suelte a presión y quite las tapas de la moldura de alrededor del borde de la cavidad de la consola central al frente y atrás de la consola.
3. Suelte a presión y quite la tapa de la consola central. (Figura A)
4. Suelte a presión el anillo de moldura que rodea el cilindro de la llave de marcha.
5. Quite (1) perno de 10 mm de la parte inferior derecha del panel de dirección debajo de la columna de dirección. Suelte a presión el panel y jale para obtener acceso atrás del panel. (Figura B)
6. Quite (1) perno de 10 mm de la parte inferior izquierda detrás del panel debajo de la columna de dirección. (Figura B)

Continúa en la siguiente página.

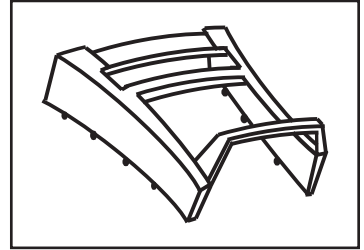

(Figura A)

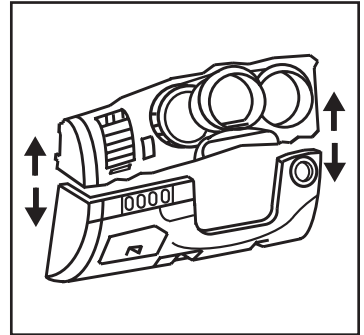

(Figura B)

Toyota 4 Runner 2003-2009 *(excluyendo limited)*

7. Quite (1) perno de 10 mm de abajo del control de clima, detrás de la puerta de la cavidad. Suelte a presión y quite el control del clima. (Figura C)
8. Quite los (2) pernos de 10 mm de abajo del radio y detrás de los controles del clima.
9. Suelte a presión y quite todo el panel central que rodea el radio. (Figura D)
10. Quite los (2) pernos de 10mm que sostienen el radio.
11. Desconecte y retire el radio.
12. Quite los soportes de fábrica del radio. Guarde los soportes para usarlos al ensamblar el kit.

Continuará al ensamble del kit

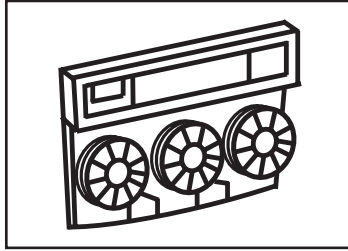

(Figura B)

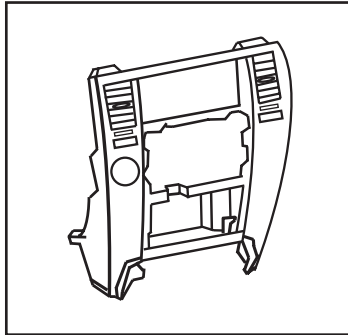

(Figura C)

Toyota Tundra 2003-2006

1. Quite las (3) perillas de control de clima jalando directamente hacia el frente. (Figura A)
2. Quite los (3) tornillos Phillips de atrás de las perillas. (Figura A)
3. Posicione las rejillas orientadas hacia arriba y quite (1) tornillo Phillips de cada rejilla de aire acondicionado. (Figura B)

Continúa en la siguiente página.

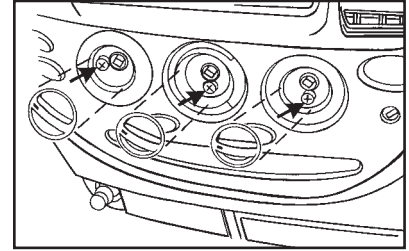

(Figura A)

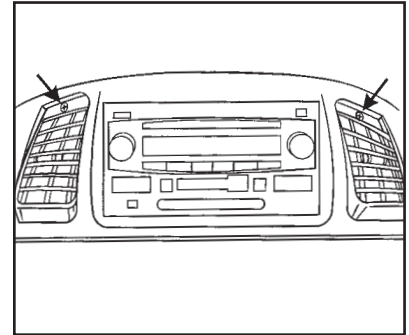

(Figura B)

Toyota Tundra 2003-2006

4. Desenganche y quite todo el panel de la moldura. (Figura C)
5. Quite los (4) pernos de 10 mm para quitar el radio. (Figura D)
6. Desconecte y retire el radio.
7. Quite los soportes de fábrica del radio. Guarde los soportes para usarlos al ensamblar el kit.

Continuará al ensamble del kit

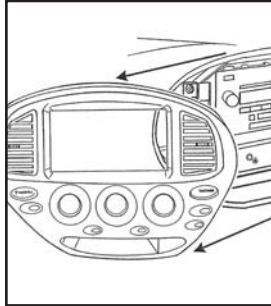

(Figura C)

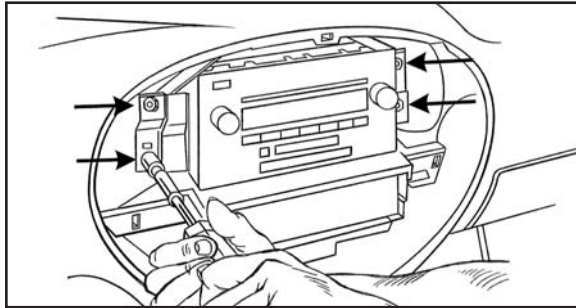

(Figura D)

Toyota Sequoia 2003-2007

1. Posicione las rejillas orientadas hacia arriba y quite (1) tornillo Phillips de cada rejilla de aire acondicionado. (Figura A)
2. Desenganche y quite todo el panel de la moldura del radio, incluyendo los controles del clima. (Figura B)
3. Quite los (4) pernos de 10 mm para quitar el radio. (Figura C)
4. Desconecte y retire el radio.
5. Quite los soportes de fábrica del radio. Guarde los soportes para usarlos al ensamblar el kit.

Continuará al ensamble del kit

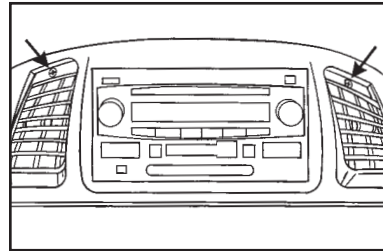

(Figura A)

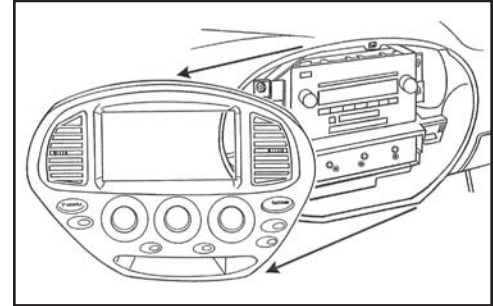

(Figura B)

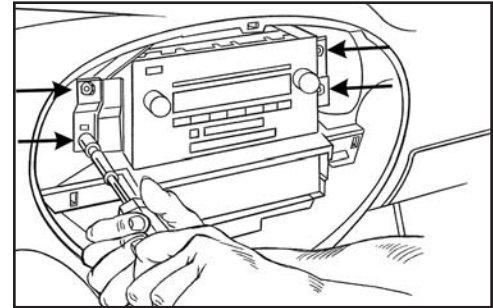

(Figura C)

Toyota FJ Cruiser 2007 y mas

1. Quite dos tornillos Phillips de la parte de abajo de los paneles de la moldura lateral. (Figura A)
2. Con una herramienta de remoción de panel, quite con cuidado los paneles de la moldura lateral. (Figura B)
3. Quite los (2) tornillos Phillips del panel de la moldura del radio. (Figura C)
4. Con la herramienta de remoción de panel, quite con cuidado el panel de la moldura del radio. (Figura D)
5. Quite los (4) pernos de 10mm que sostienen el radio.
6. Desconecte y retire el radio.
7. Quite los soportes de fábrica del radio. Guarde los soportes para usarlos al ensamblar el kit.

Continuará al ensamble del kit

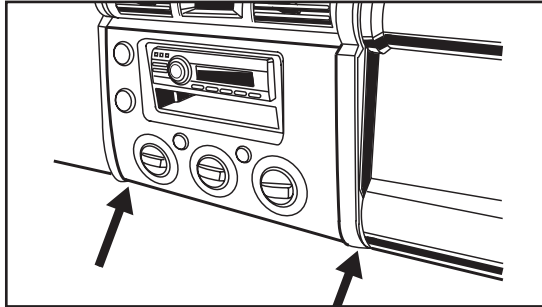

(Figura A)

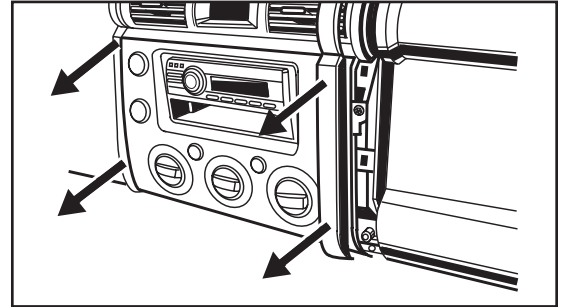

(Figura B)

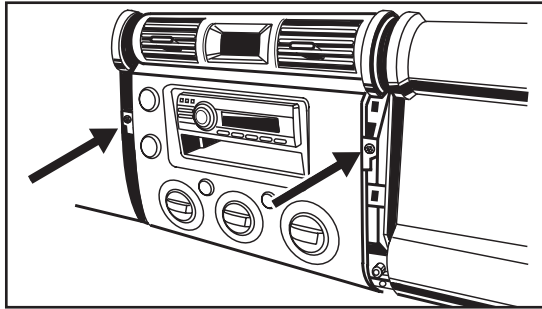

(Figura C)

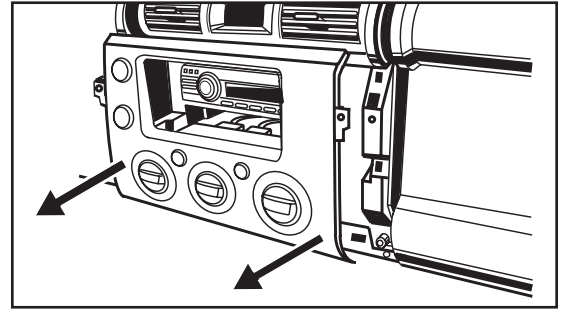

(Figura D)

Yaris 2007-2011 (sin paquete de energía)

1. Desenganche el panel de la moldura inferior localizado abajo de los controles de aire acondicionado. (Figura A)
2. Desenganche los dos paneles de la moldura lateral que rodean los controles de aire acondicionado y el radio. (Figura A)
3. Desenganche el panel de la moldura de instrumentos que rodea el velocímetro y los indicadores. (Figura B)
4. Desenganche el panel de la moldura del radio/las rejillas de aire acondicionado. (Figura B)
5. Quite los (4) tornillos Phillips que sostienen el radio. (Figura C)
6. Desconecte y retire el radio.
7. Quite los (4) tornillos Phillips que sujetan los soportes de fábrica a cada lado del radio y quite los soportes. Guarde los soportes para usarlos al ensamblar el kit. (Figura D)

Continuará al ensamble del kit

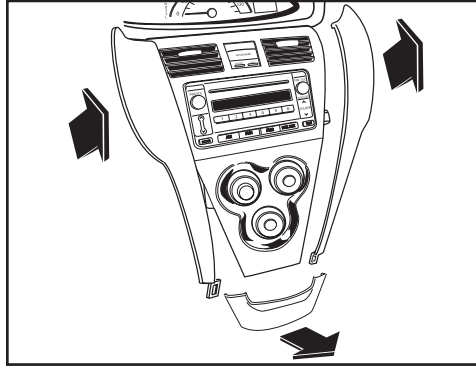

(Figura A)

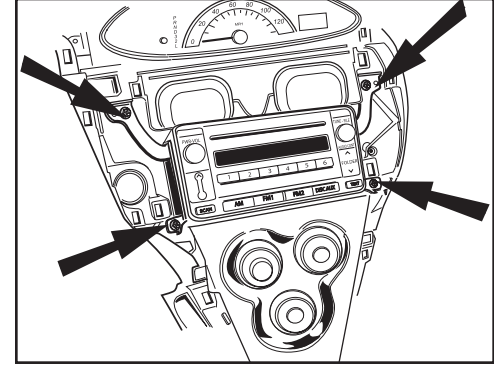

(Figura C)

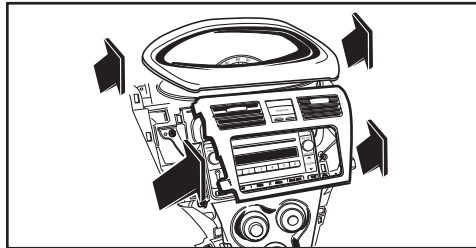

(Figura B)

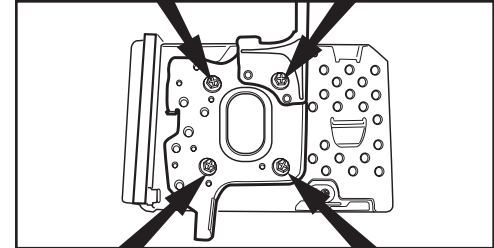

(Figura D)

Yaris 2012 y mas

1. Desenganche y quite todo el panel, incluyendo la rejilla de aire acondicionado en el tablero del lado del pasajero. (Figura A)
2. Desenganche y quite el panel de alrededor del radio. (Figura B)
3. Quite los cuatro pernos de 10 mm y quite el radio de fábrica. (Figura C)

Continuará al ensamble del kit

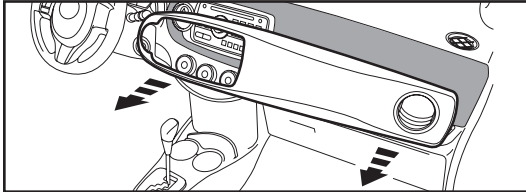

(Figura A)

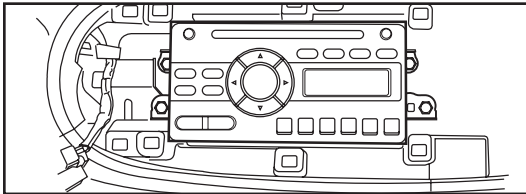

(Figura B)

Scion FR-S 2013 y mas

1. Desenganche y quite el panel de alrededor del radio. (Figura A)
2. Quite los cuatro pernos de 10 mm y quite el radio de fábrica. (Figura B)

Continuará al ensamble del kit

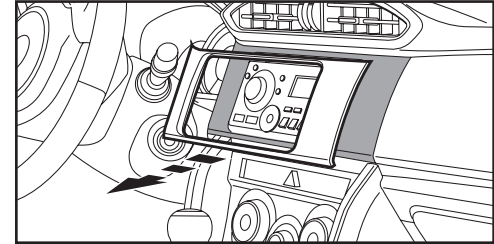

(Figura A)

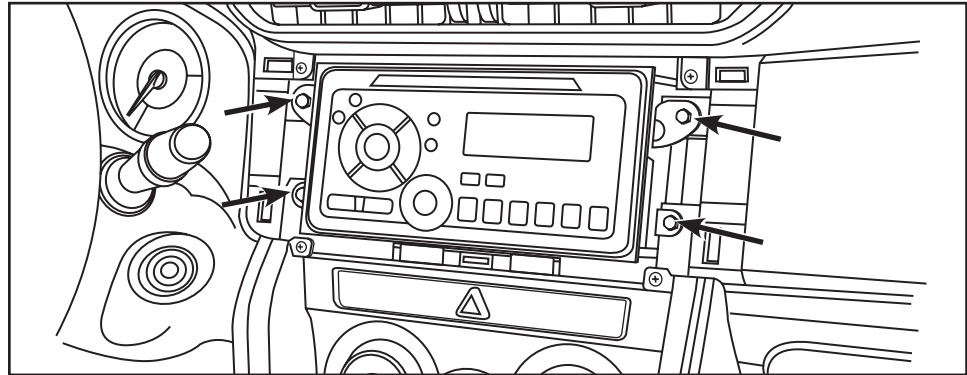

(Figura B)

Scion IQ 2012 y mas

1. Desenganche y quite el panel del control del clima. (Figura A)
2. Desenganche y quite el panel de alrededor del radio. (Figura B)
3. Quite los cuatro pernos de 10 mm y quite el radio de fábrica. (Figura C)

Continuará al ensamble del kit

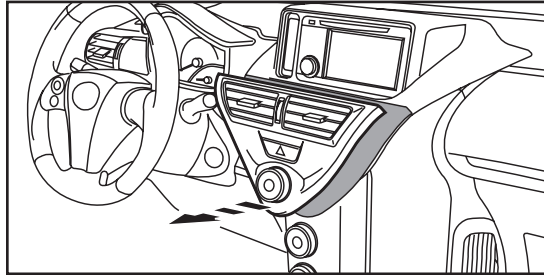

(Figura A)

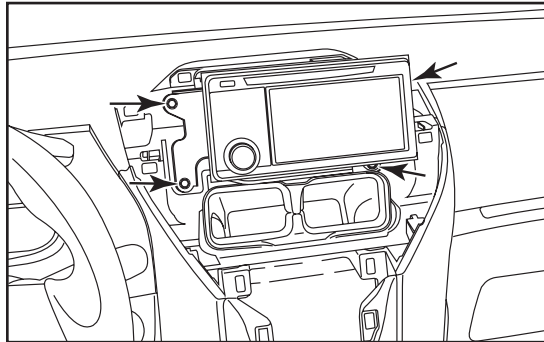

(Figura C)

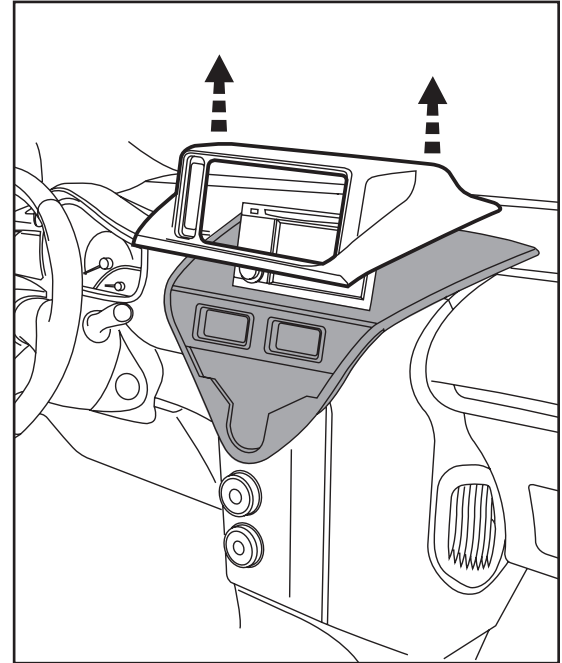

(Figura B)

Scion XA 2004-2006

1. Jale hacia afuera las (3) perillas de control de clima y quítelas. (Figura A)
2. Quite los (2) tornillos Phillips de la parte de atrás de las dos perillas exteriores del clima. (Figura B)
3. Suelte a presión y quite las piezas de moldura de cada lado del ensamble del control de clima/cenicero/bolsillo. (Figura C)
4. Quite los (2) tornillos Phillips de la parte inferior del panel del control de clima/radio y luego suelte a presión y quite todo el panel. (Figura D)
5. Quite los (4) tornillos Phillips para quitar el radio de fábrica.
6. Quite los soportes de fábrica del radio. Guarde los soportes para usarlos al ensamblar el kit.

Continuará al ensamble del kit

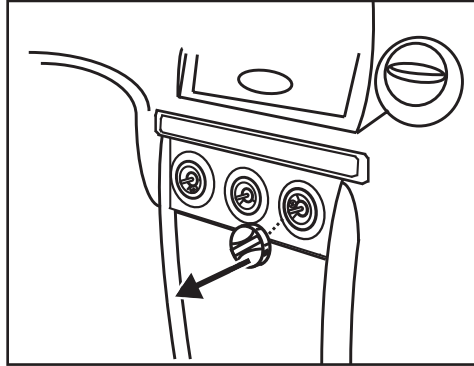

(Figura A)

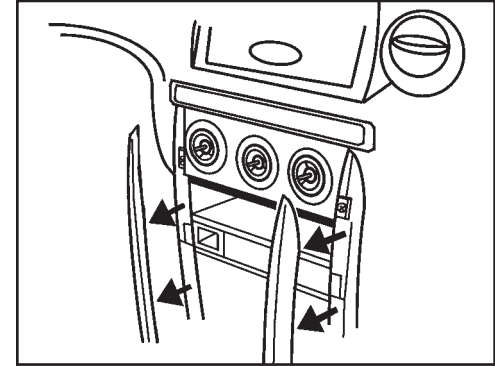

(Figura C)

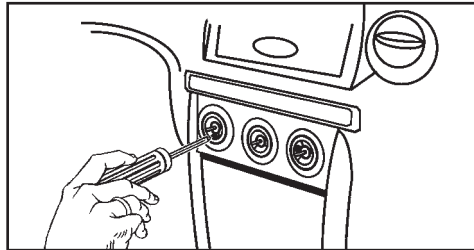

(Figura B)

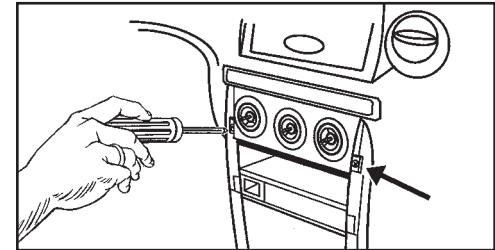

(Figura D)

Scion XB 2004-2006

1. Jale hacia afuera las (3) perillas de control de clima y quítelas. (Figura A)
2. Quite los (2) tornillos Phillips de la parte de atrás de las perillas exteriores (2). (Figura B)
3. Suelte a presión y quite todo el panel que rodea el radio y los controles del clima y aire acondicionado. (Figura C)
4. Quite los (4) tornillos Phillips para quitar el radio de fábrica.
5. Quite los soportes de fábrica del radio. Guarde los soportes para usarlos al ensamblar el kit.

Continuará al ensamble del kit

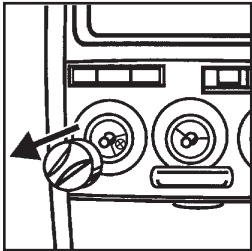

(Figura A)

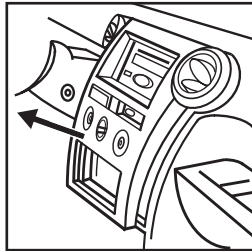

(Figura B)

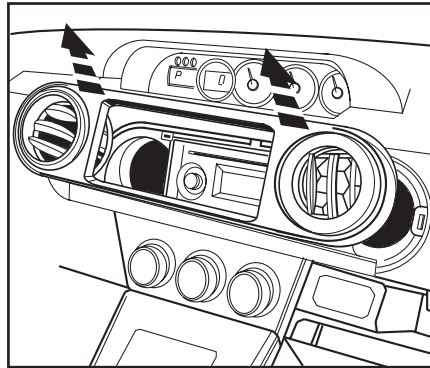

(Figura A)

Scion XB 2008 y mas

1. Desenganche y quite el panel de moldura que rodea el radio, incluyendo las rejillas del aire acondicionado. (Figura A)
2. Desenganche y quite el panel de moldura del borde inferior de la cavidad del tablero. (Figura B)
3. Quite los (4) pernos de 10 mm que sujetan el radio. (Figura C)

Continuará al ensamble del kit

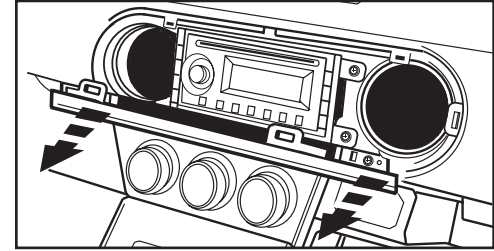

(Figura B)

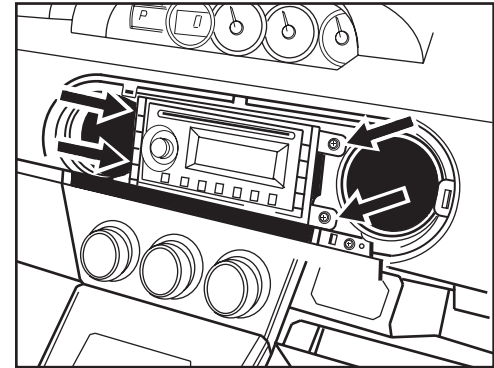

(Figura C)

Scion TC 2005-2010

1. Suelte a presión la moldura que rodea la palanca de velocidades (no es necesario quitarla). (Figura A)
2. Desenganche y quite el panel que rodea el radio (incluyendo los controles del clima y la puerta del radio). (Figura B)
3. Quite (2) tuercas de 10 mm de las ubicaciones superiores de montaje y (2) pernos de 10 mm de las ubicaciones inferiores de montaje y quite el radio. (Figura C)
4. Quite los soportes de fábrica del radio. Guarde los soportes para usarlos al ensamblar el kit.

Continuará al ensamble del kit

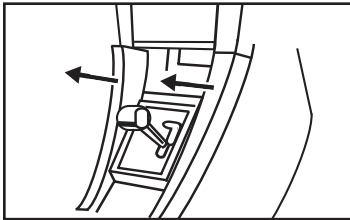

(Figura A)

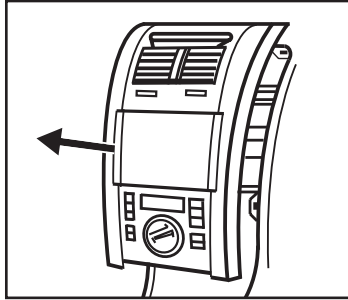

(Figura B)

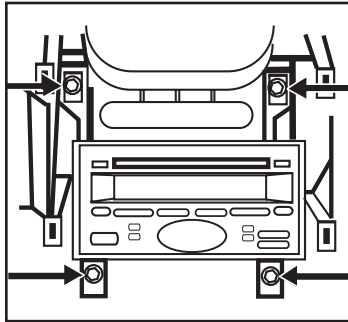

(Figura C)

Scion TC 2011 y mas

1. Desenganche y quite el panel de la moldura del radio. (Figura A)
2. Quite los (4) pernos de 10mm que sostienen el radio. (Figura B)
3. Quite los soportes de fábrica del radio. Guarde los soportes para usarlos al ensamblar el kit.

Continuará al ensamble del kit

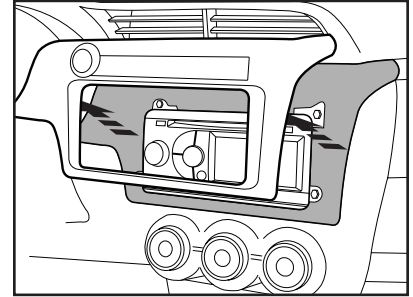

(Figura A)

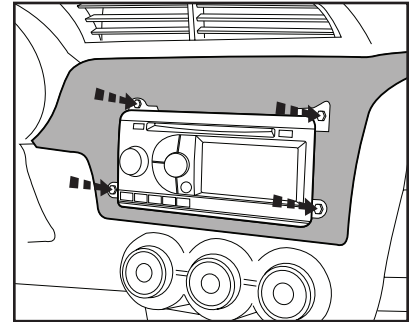

(Figura B)

Scion XD 2008 y mas

1. Desenganche el panel de moldura del radio. Desconecte y retire el panel. (Figura A)
2. Retire los (4) tornillos Phillips que sostienen el radio. Desconecte y quite el radio. (Figura B)
3. Quite los soportes de fábrica del radio. Guarde los soportes para usarlos al ensamblar el kit. (Figura C)

Continuará al ensamble del kit

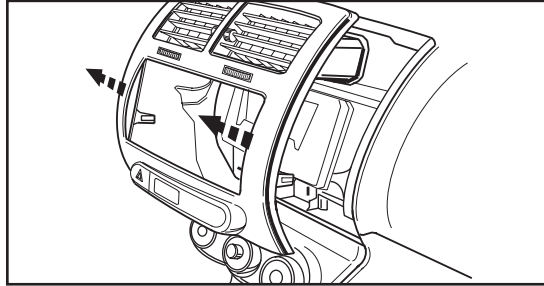

(Figura A)

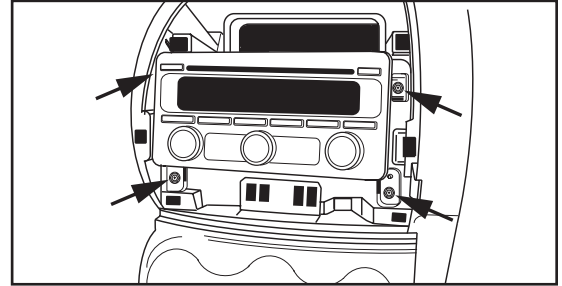

(Figura B)

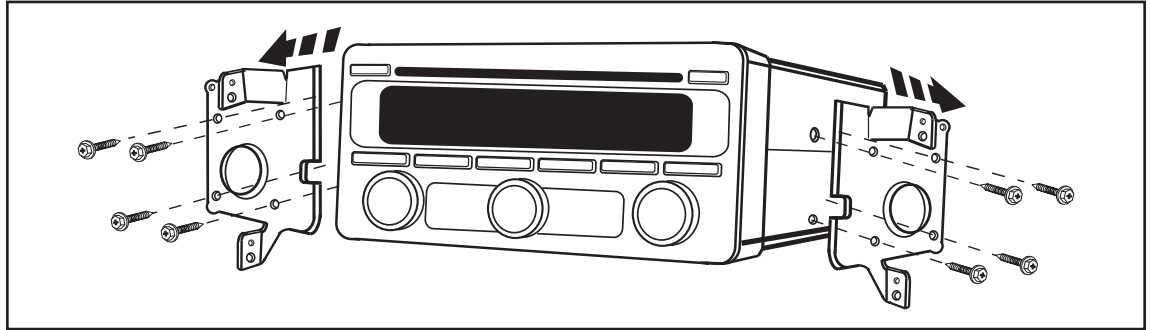

(Figura C)

Subaru BRZ 2013 y mas

1. Desenganche y quite el panel de alrededor del radio. (Figura A)
2. Quite los cuatro pernos de 10 mm y quite el radio de fábrica. (Figura B)

Continuará al ensamble del kit

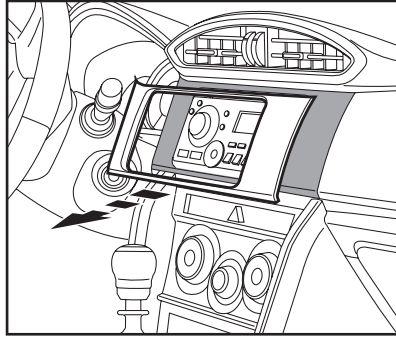

(Figura A)

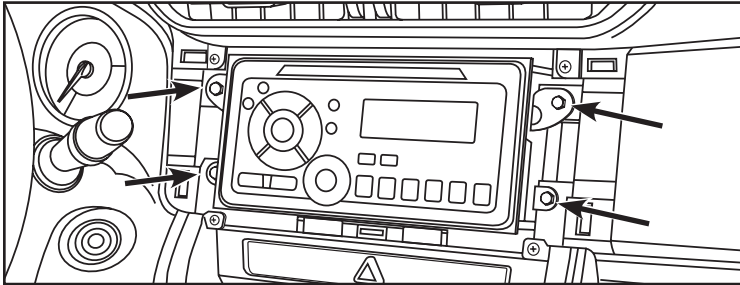

(Figura B)

**Subaru Forester (con navegación basada en SD)
2009 y mas**

1. Desenganche y quite el panel de moldura que rodea el radio de fábrica, incluyendo las rejillas del aire acondicionado. (Figura A)
2. Retire los (4) tornillos Phillips que sostienen el radio. Desconecte y quite el radio. (Figura B)

Continuará al ensamble del kit

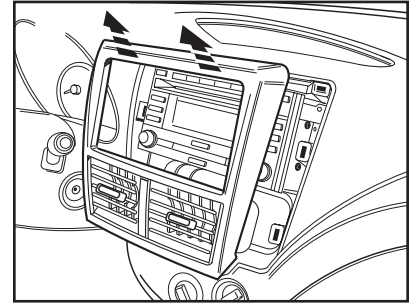

(Figura A)

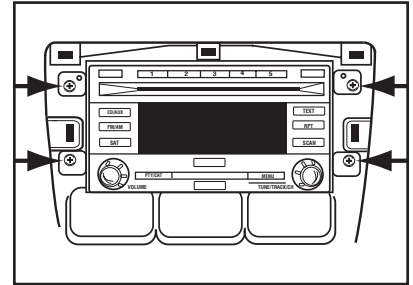

(Figura B)

Preparación del kit

Para el Scion TC (ambas generaciones) y XA:

Corte la sección delantera superior de las placas de moldura doble DIN como se muestra en las líneas punteadas rotuladas "A" en la . (Figura A)

Para Toyota Rav4 2001-2005, Toyota Highlander 2001-2007 (sin navegación de fábrica), Toyota Tundra 2003-2006 y Toyota Sequoia 2003-2007:

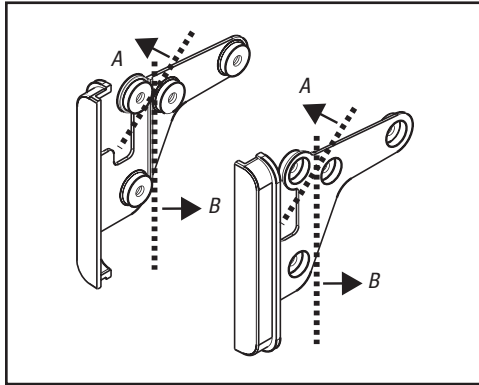

(Figura A)

Corte la sección trasera de las placas de moldura doble DIN como se muestra en las líneas punteadas rotuladas "B" en la . (Figura A)

Para Scion FR-S 2013 y más recientes y Subaru BRZ:

Corte la placa de moldura doble DIN como se muestra en la . (Figura B)

Nota: Debe tener cuidado al cortar. Debe utilizar una herramienta Dremel y una mano firme. En caso de

que el soporte esté dañado, puede utilizarlo usando el orificio sobrante para un solo tornillo. Si elige esta opción, tendrá que soportar la parte posterior del radio para impedir que caiga. (Figura B)

Para todos los demás vehículos, proceda al Paso 1.

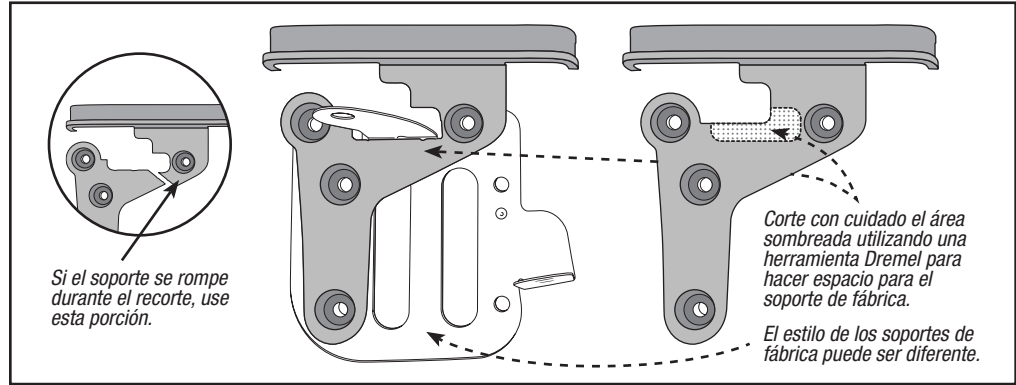

(Figura B)

Provisión de radio doble DIN

1. Coloque los soportes de montaje de fábrica y las placas de moldura doble DIN 95-8202 al radio doble DIN con los tornillos suministrados con la unidad. (Figura B)

Nota: Quite las clavijas localizadoras de los soportes de fábrica con la rectificadora.

2. Ubique el arnés de cableado de fábrica en el tablero. Metra recomienda el uso de un adaptador adecuado de acoplamiento de Metra o de AXXESS. Vuelva a conectar la terminal negativa de la batería y pruebe la unidad para verificar que funcione correctamente.
3. Vuelva a armar el tablero al revés de como lo desarmó.

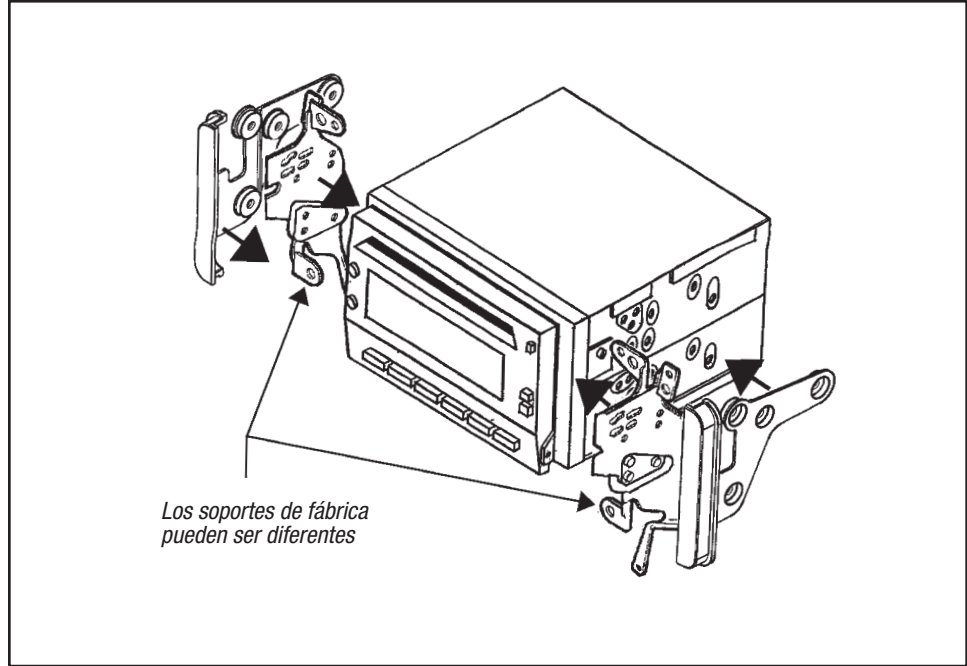

(Figura A)



INSTRUCCIONES DE INSTALACIÓN PARA LA PIEZA 95-8202



REV. 7/9/2014 INST95-8202



EL CONOCIMIENTO ES PODER
Mejore sus habilidades de instalación y fabricación inscribiéndose en la escuela de dispositivos electrónicos móviles más reconocida y respetada de nuestra industria. Regístrese en www.installerinstitute.com o llame al 800-354-6782 para obtener más información y avance hacia un futuro mejor.



Metra recomienda técnicos con certificación del Programa de Certificación en Electrónica Móvil (Mobile Electronics Certification Program, MECP).