

Double DIN installation

1. Depending on the double DIN head unit you want to install stick the appropriate trim frame(s)* to facia plate and fix them with glue

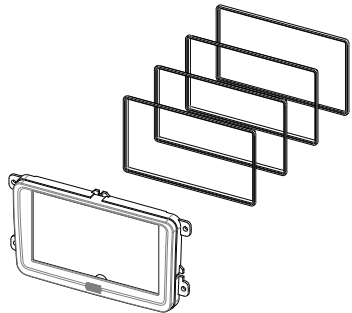

*** trim frame set has to be ordered separately: part-no.: 271000-13**

2. Mount metal brackets to double DIN head unit

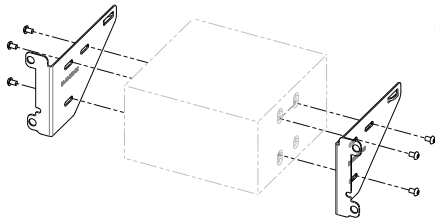

Connect all required circuit points and push double DIN head unit into dashboard

3. (Optional: install microphone in pocket of the backside of facia plate)

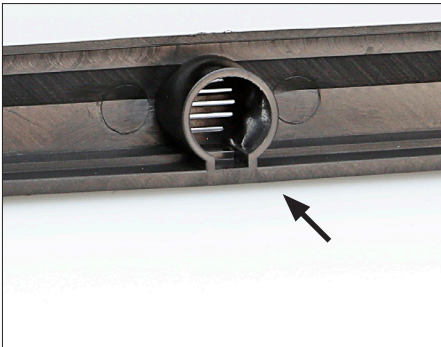

4. Push facia plate over double DIN head unit and fix it with original Torx (TX20) screws

Reinstall everything in reverse order to finish installation.



SEAT
Seat Leon (1P/1PN) 03/2009 – 10/2012
Seat Alhambra (7N) 10/2010->

SKODA*
Skoda Fabia (5J) 2007->
Skoda Roomster (5J) 09/ 2006-> (nur mit OEM-Radio)
Skoda Octavia II (1Z) Facelift 01/2009
Skoda Superb (3T) 07/2008->
Skoda Rapid (NH) 10/2012->
**(If a Columbus OEM-Navigation is installed, 3T0858061QB by Skoda is required)*

VOLKSWAGEN
VW Amarok (2H) 03/2010->
VW Beetle (16) 04/2011->
VW Caddy (2K)01/2004->
VW CC (3CC) 01/2012->
VW Eos (1F) 05/2006 >
VW Golf V (1K) 10/2003-06/2008
VW Golf V Variant (1KM) 06/2007-10/2009
VW Golf Plus (1KP) 03/2005->
VW Golf VI (1K) 11/2008-10/2012
VW Golf VI Variant (1KM) 11/2009->
VW Golf VI Cabrio (1K) 06/2011->

VW Jetta V (1KM) 08/2005-10/2010
VW Jetta VI (16) 01/2011->
VW Passat B6/B7(3C/3AA) 06/2005->
VW Passat CC (3CC) 06/2008-2012
VW Polo V (6R) 03/2009->
VW Sharan II (7N) 09/2010->
VW Scirocco (13) 08/ 2008->
VW Tiguan (5N) 04/2007->
VW Touran (1T / GP2) 02/2003->
VW T5 Multivan (Facelift) 10/2009->
VW T5 Transporter (Facelift) 10/2009->

Compatible these double DIN devices

Double-DIN navigation

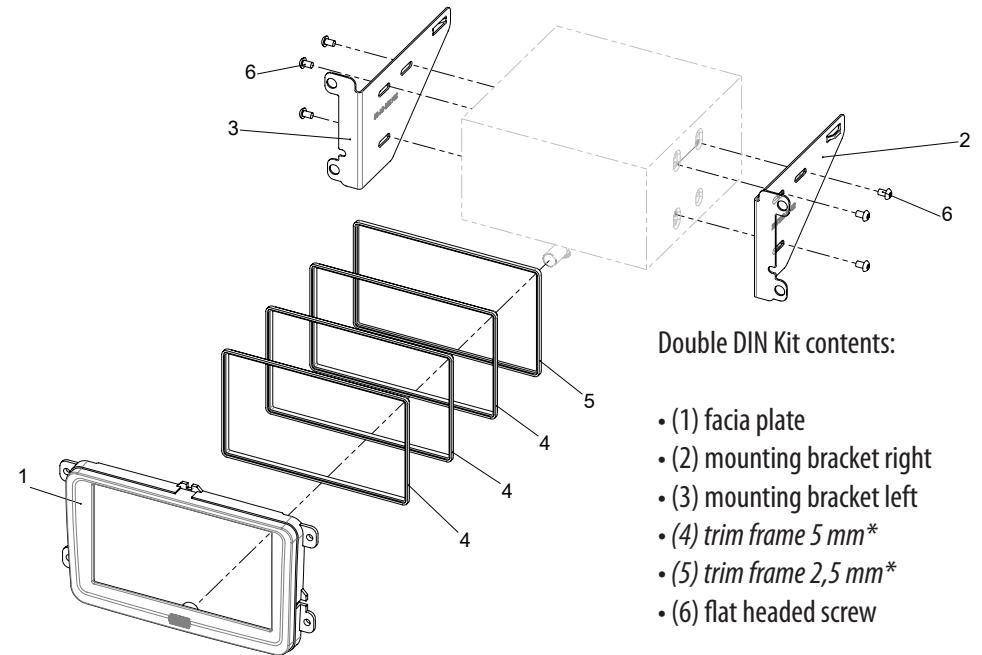

Double DIN Kit contents:

- (1) facia plate
- (2) mounting bracket right
- (3) mounting bracket left
- (4) trim frame 5 mm*
- (5) trim frame 2,5 mm*
- (6) flat headed screw

** trim frame set has to be ordered separately: part-no.: 271000-13*

*All installation work must be performed by a qualified professional installer only.
The manufacturer / dealer is not liable for any kind of incidental or indirect damages.*

VW Golf V

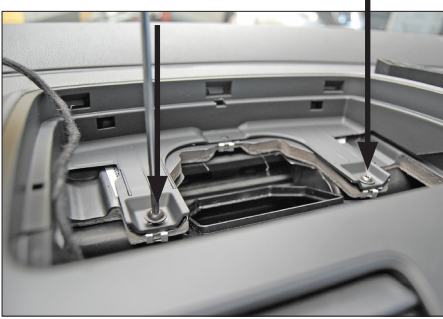

- A. Pull up the aircone unit (fixed by clips). Remove two Torx (TX20) screws (see arrows) which became visible



- B. Remove the original trim frame, surrounding the radio (fixed by clips).



- C. Remove the 4 Torx (TX20) screws (These screws will be used again later)

Remove OEM head unit

Proceed to Double DIN installation on last page

All other VW (universal)



- A. Remove the original trim frame, surrounding the radio (fixed by clips).



- B. Remove the 4 Torx (TX20) screws (These screws will be used again later)

Remove the OEM head unit

Proceed to Double DIN installation on last page

VW Tiguan



A. Unclip and remove OEM panel



B. Remove 4 screws of OEM head unit



C. Remove OEM head unit
Proceed to Double DIN installation on last page

Škoda Fabia II / Octavia II / Roomster / VW Caddy / Touran

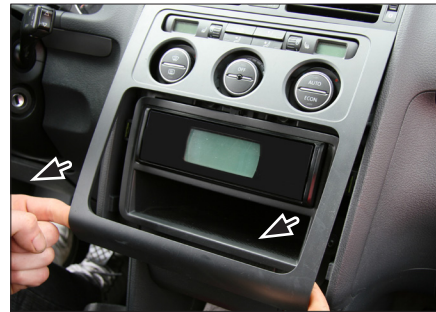

A. Unclip and remove OEM panel (see arrows)



B. Remove 4 screws
Remove head unit

Proceed to Double DIN installation on last page

Seat Alhambra / VW Sharan

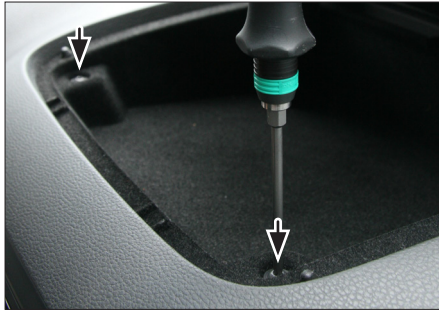

- A. Open top shelf
Remove 2 screws



- B. Remove top shelf inlay
Remove 2 screws on top



- C. Remove OEM panel



- D. Remove 4 screws
Remove OEM head unit
Proceed to Double DIN installation on last page

VW Tiguan



- A. Unclip and remove OEM panel
(see arrows)

Remove 4 screws of
OEM head unit



- B. Remove 4 screws

Remove head unit

Proceed to Double DIN
installation on last page