

# *Procédure de montage d'un système de navigation dans une SAAB 9.5.*



**Kit d'intégration : 12.301270-03**



**Kit de démultiplexage : CTSSA001**

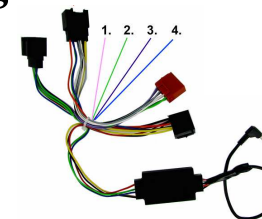

**Câble iPod : CD-IU230V**



# Dépose de l'autoradio d'origine



*Sortir les quatre  
bouchons  
de la radio  
d'origine*

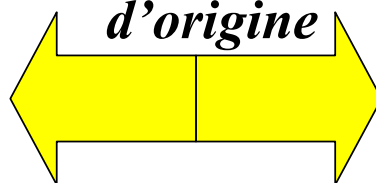

*Sortir  
l'autoradio*

*Dévisser les quatre  
vis de fixation*

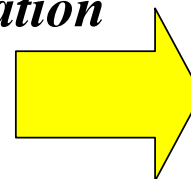
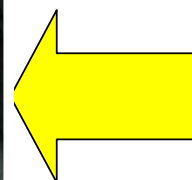



# *Coller d'antenne GPS sous la baguette du par brise*



*Coller la plaque  
métallique*



*Poser l'antenne sur la  
plaque métallique*

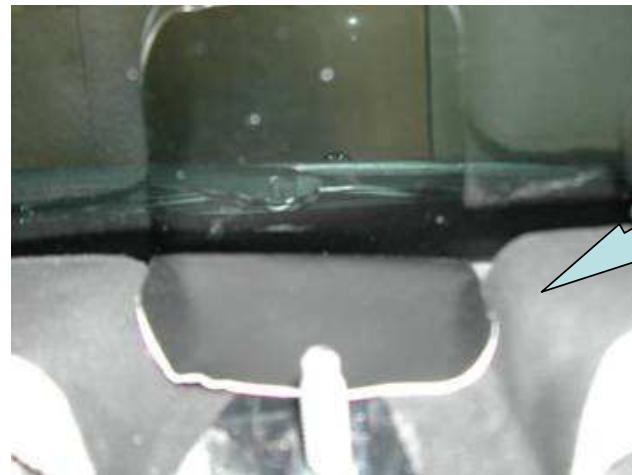

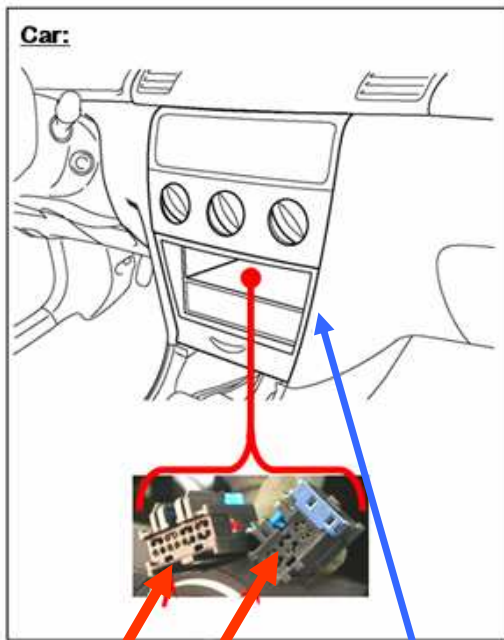

# Connexions des fils

## Signal de vitesse

Fil Rose de l'adaptateur avec le fil Rose Pioneer **CAR SPEED SIGNAL INPUT**

## Signal marche arrière

Fil Violet/Blanc de l'adaptateur avec le fil Violet/Blanc Pioneer **REVERSE-GEAR SIGNAL INPUT**

## Signal Frein à main

Fil Vert de l'adaptateur avec le fil vert **PARKING BRAKE Pioneer**

Connecter les deux fils bleu **ANTENNA CONTROL Pioneer** ensemble.

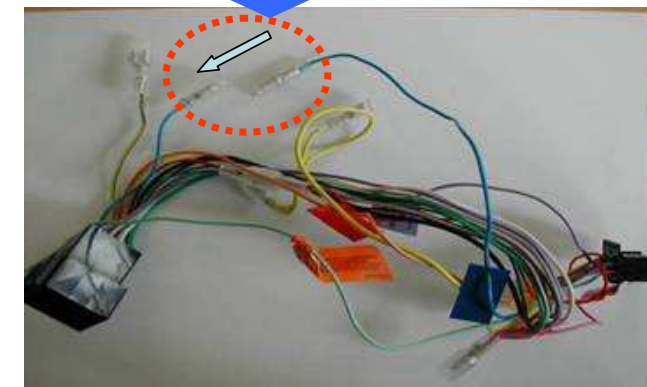
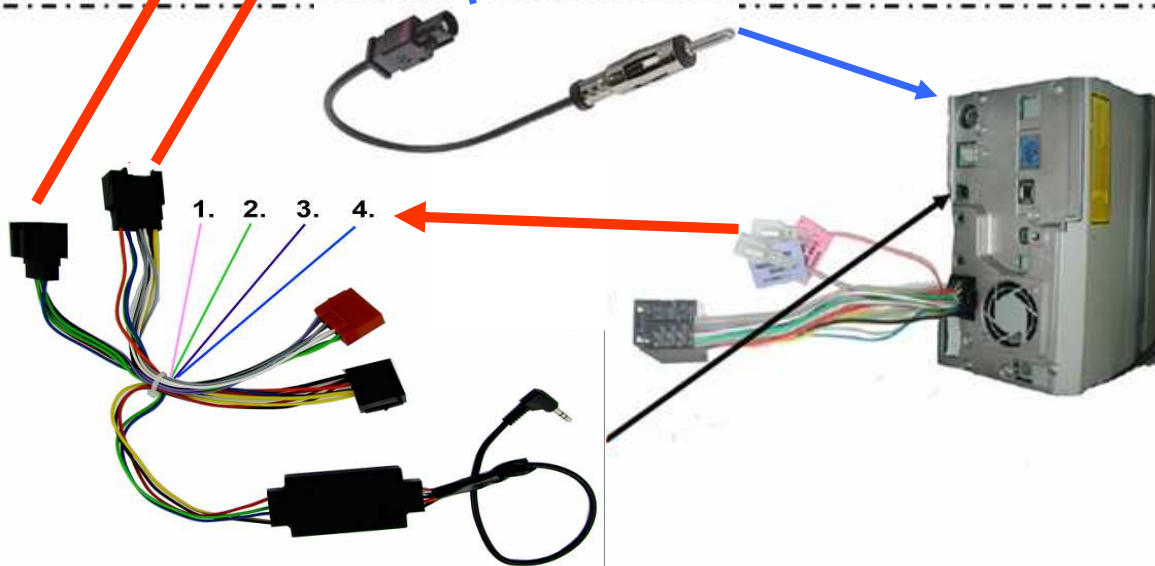

# Connexions des fils

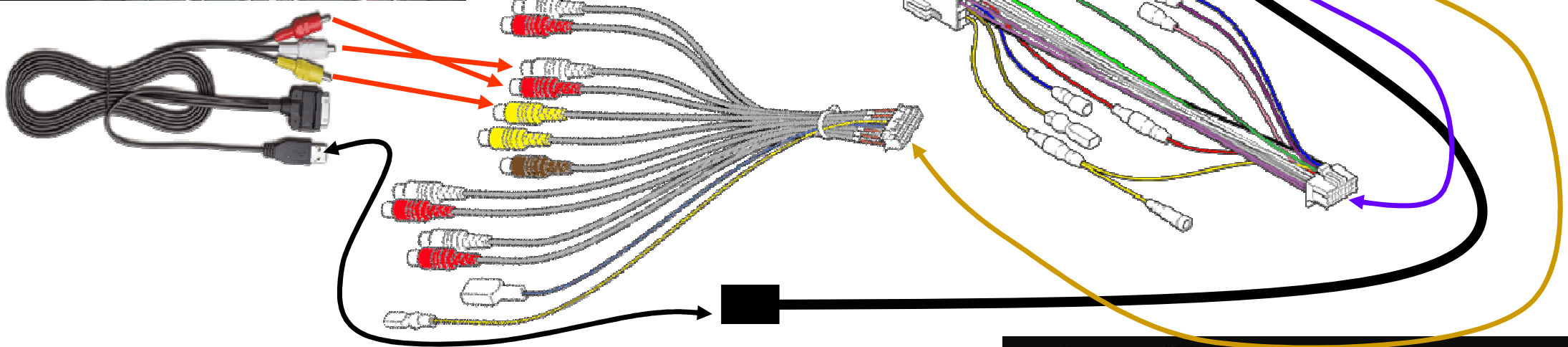
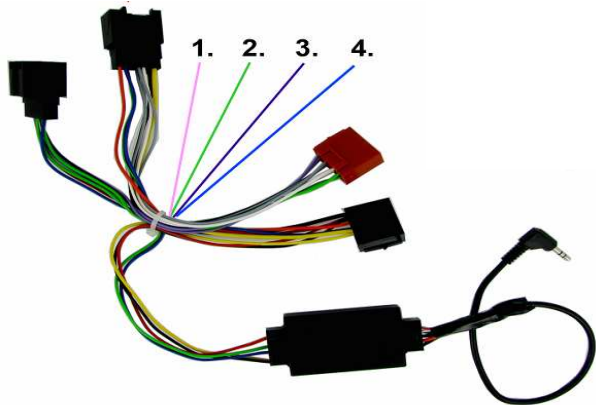



# *Installation du micro kit main libre et commande vocale*

## *Passage du câble du micro*



*Fixer le micro à l'aide de sa patte de fixation*

# Démontage de l'autoradio.

- **Retirer le support.**

Dévisser les vis (3 mm × 6 mm) pour retirer le support.

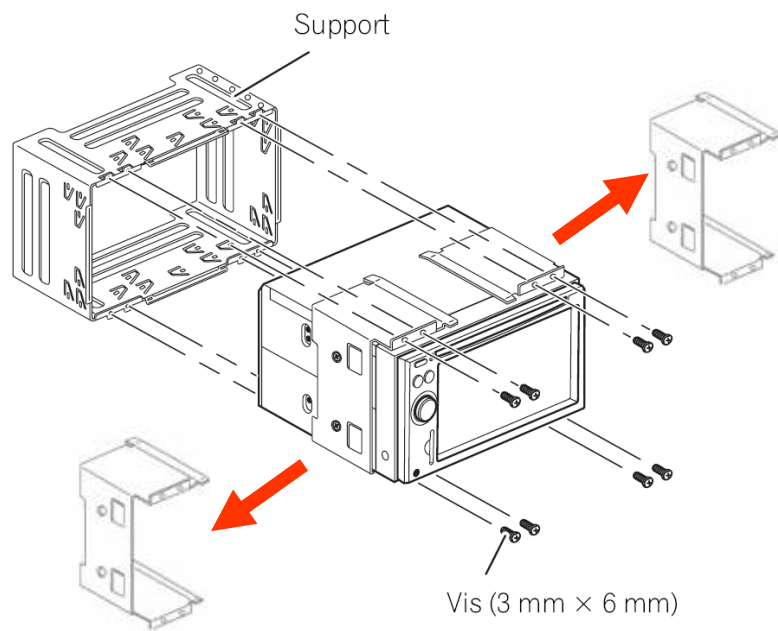

# Préparation de l'autoradio.

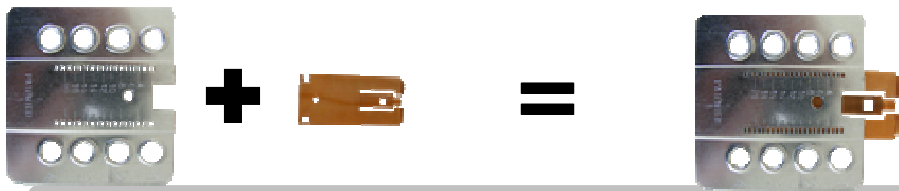
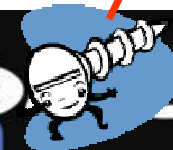
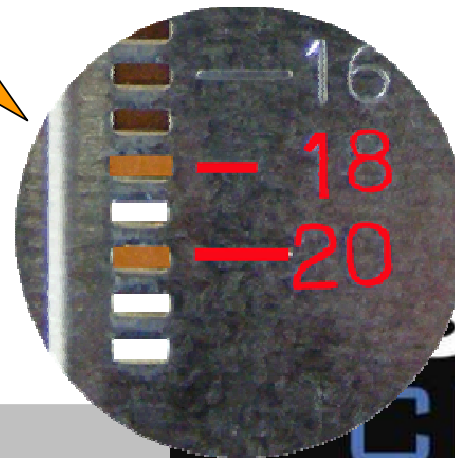
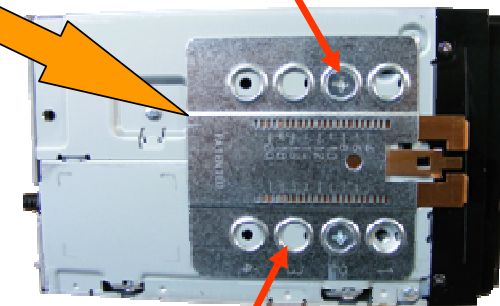
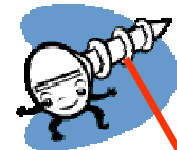
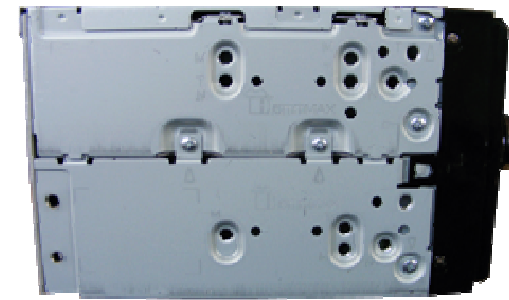
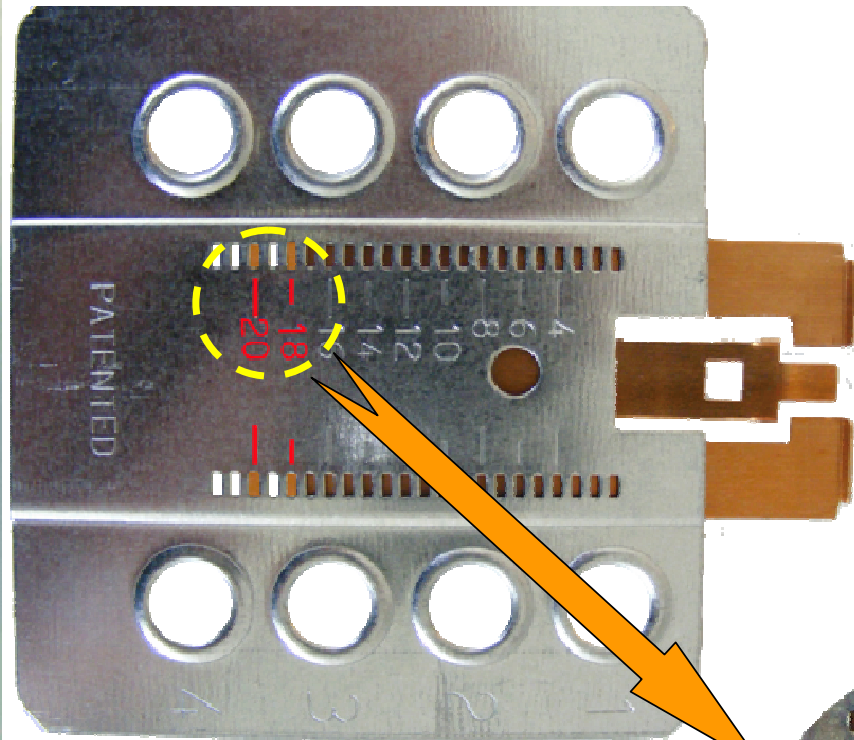

<https://pioneer.fr/pioneercip>

Pioneer  
CIP



# *Fixation de l'autoradio et remontage des caches*



*Positionner le cache plastique dans la ceinture métallique.*

*Fixer la ceinture métallique à l'aide d'un tournevis pour Tordre les pattes.*



*Coller les deux mousses entre la ceinture métallique et la partie plastique de la voiture.*



## *Fixation de l'autoradio et remontage des caches*



<https://pioneer.fr/pioneercip>

