

# *Procédure de montage d'un système de navigation dans une SAAB 9.3.*

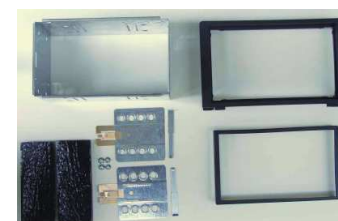

**Kit d'intégration : 12.301270-01**



**Kit de démultiplexage : CTSSA001**

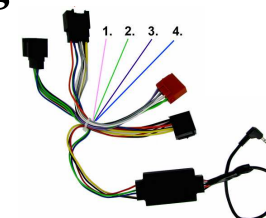

**Câble iPod : CD-IU230V**



# *Dépose de l'autoradio d'origine*



*Extraire la grille  
d'extraction  
d'aire*

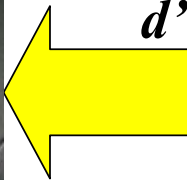

*Sortir l'autoradio*

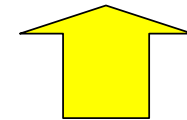
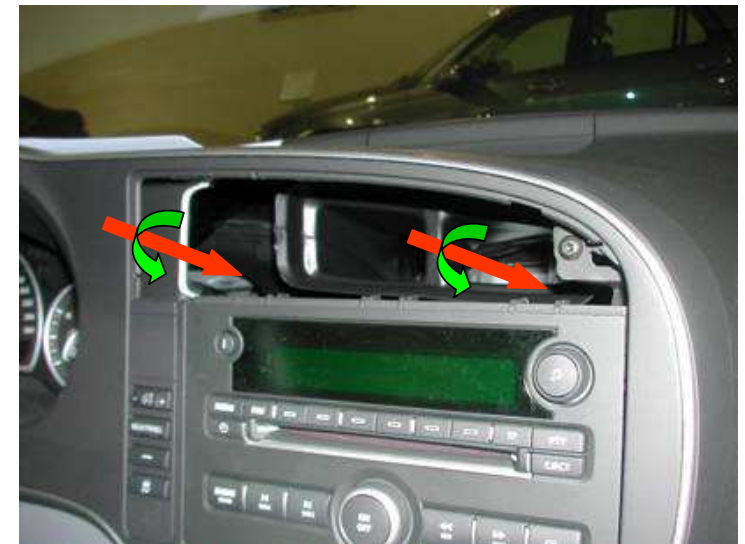

*Dévisser les deux  
vis de fixation de  
l'autoradio*

# *Installation de l'antenne GPS*



*Coller la plaque métallique **1**  
sur la bouche d'aire,  
Poser l'antenne satellite **2** sur  
la plaque métallique*

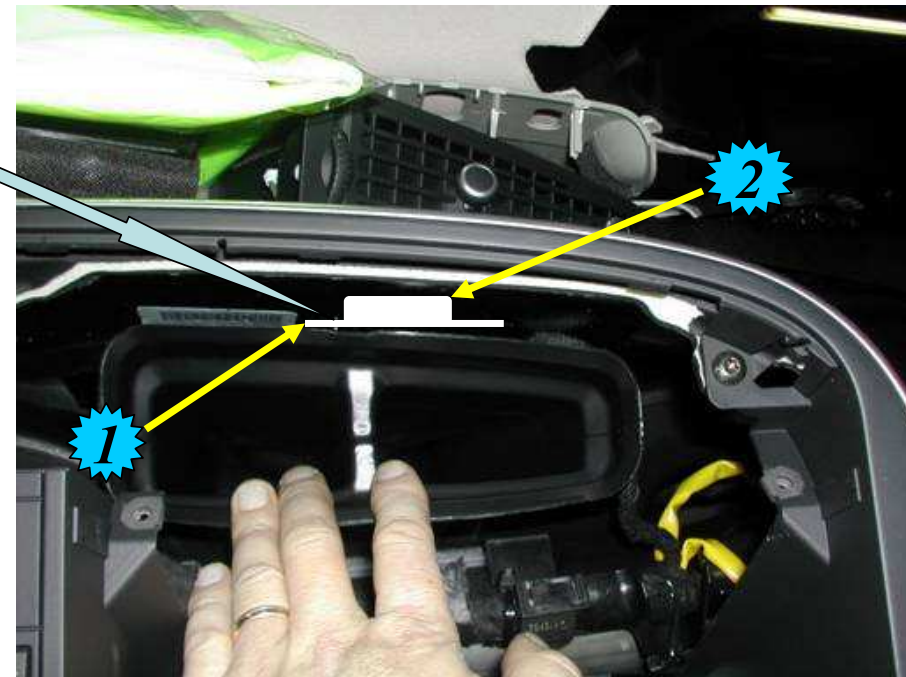

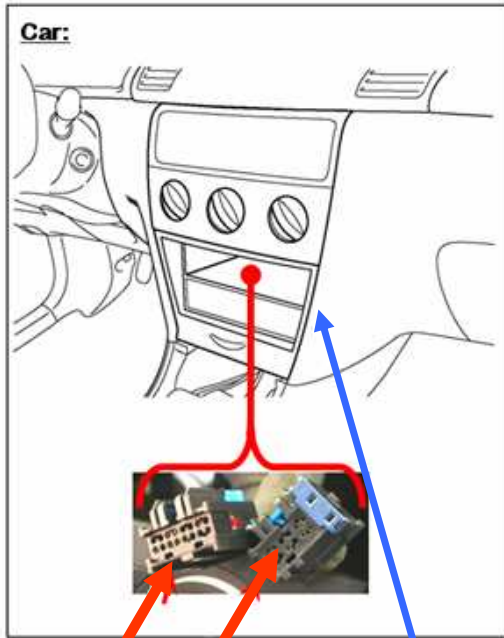

# Connexions des fils

## Signal de vitesse

Fil Rose de l'adaptateur avec le fil Rose Pioneer **CAR SPEED SIGNAL INPUT**

## Signal marche arrière

Fil Violet/Blanc de l'adaptateur avec le fil Violet/Blanc Pioneer **REVERSE-GEAR SIGNAL INPUT**

## Signal Frein à main

Fil Vert de l'adaptateur avec le fil vert **PARKING BRAKE Pioneer**

Connecter les deux fils bleu **ANTENNA CONTROL Pioneer ensemble.**

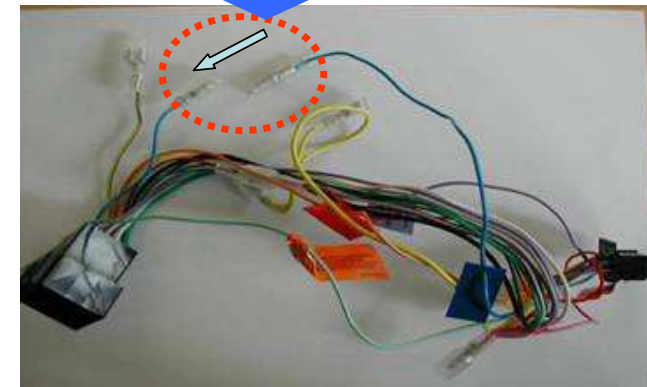
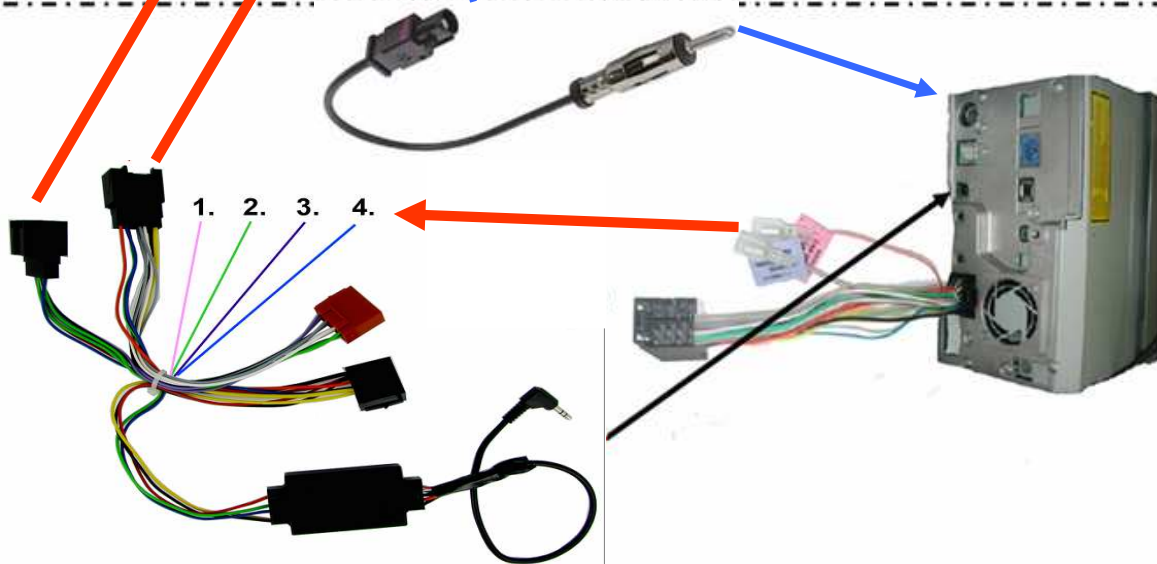

# Connexions des fils

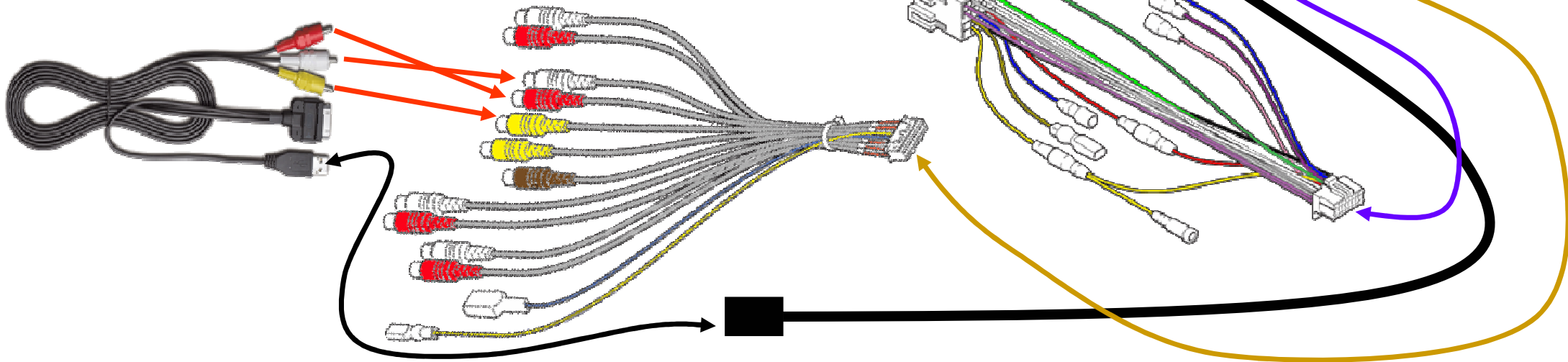
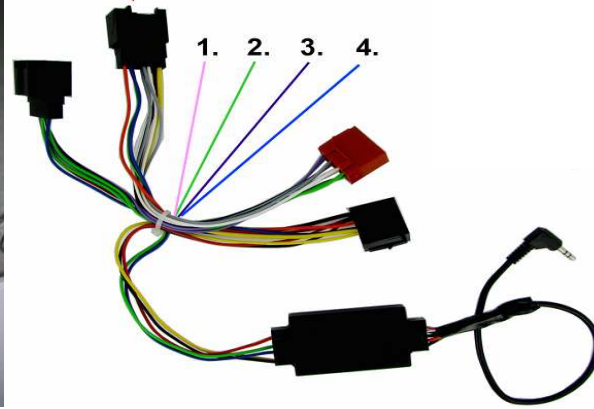
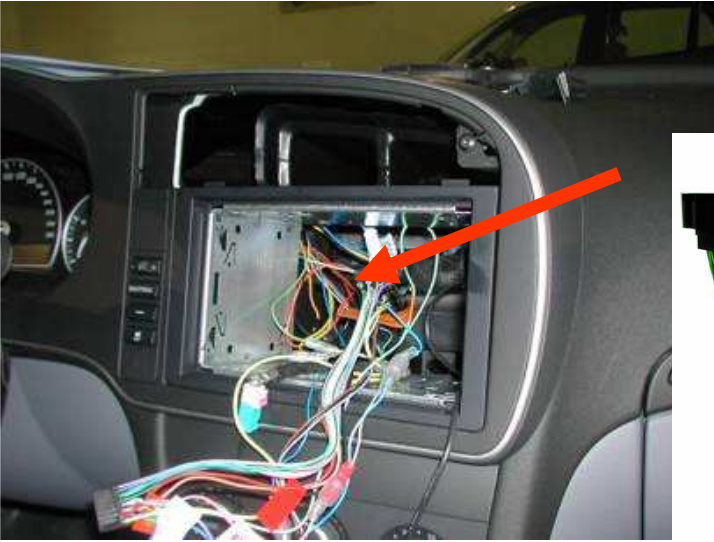

# *Démontage de l'autoradio.*

- **Retirer le support.**

Dévisser les vis (3 mm × 6 mm) pour retirer le support.

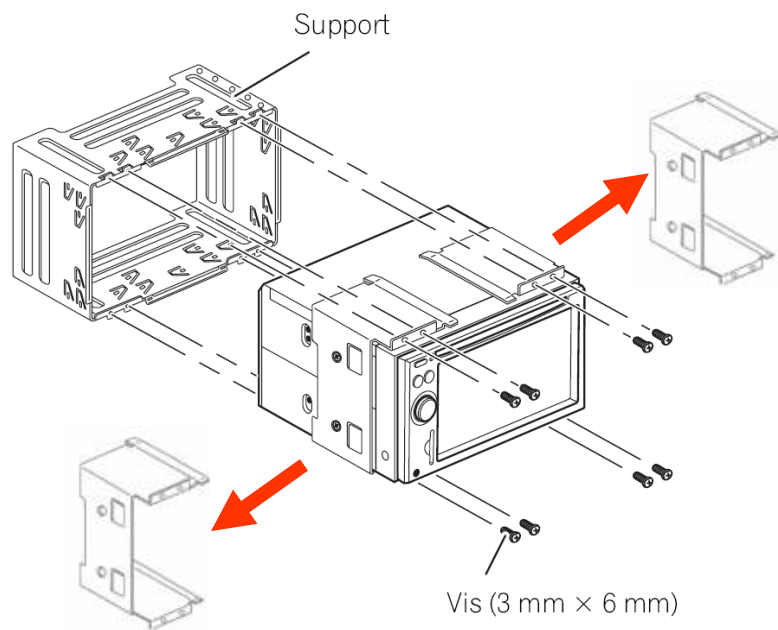

# *Installation du micro kit main libre et commande vocale*

*Démonter le cache montant pour passez le fil du micro*

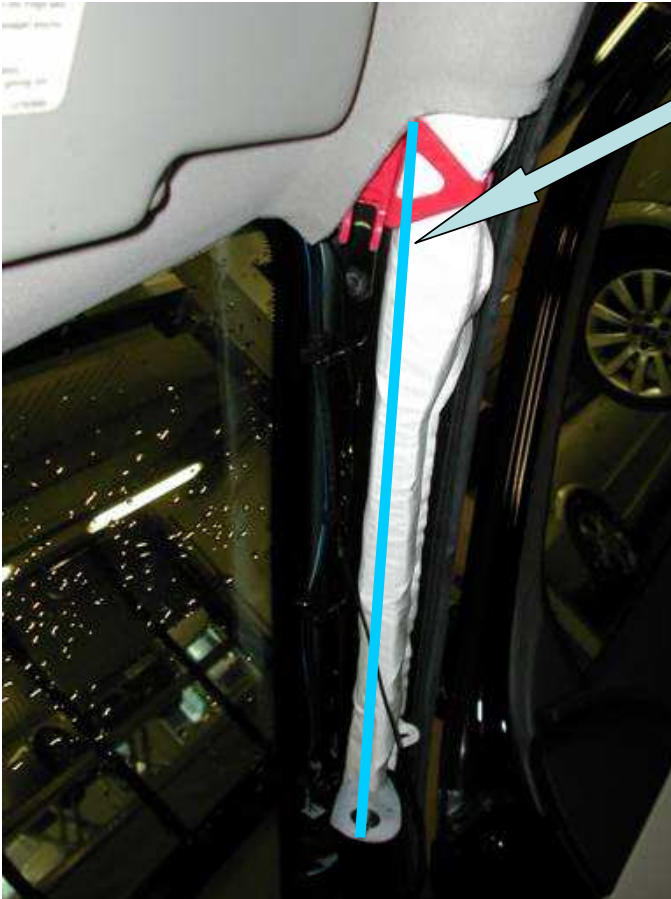

*Passage du câble du micro*



*Fixer le micro à l'aide de sa patte de fixation*

# *Préparation de l'autoradio.*

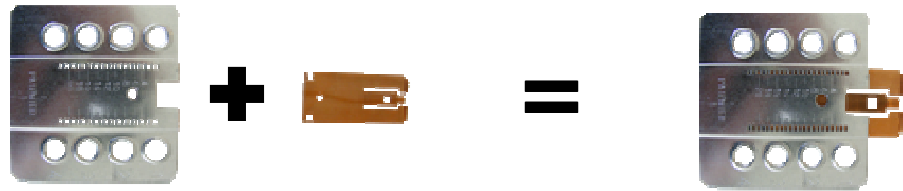
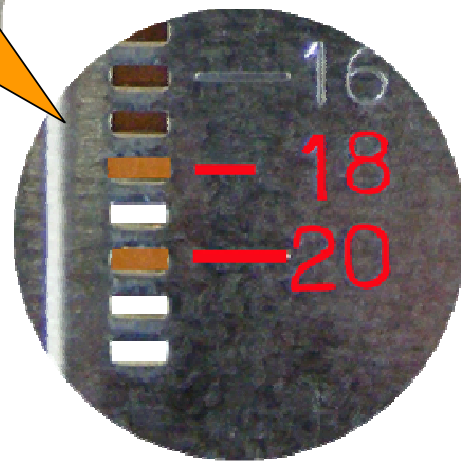
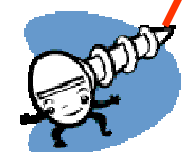
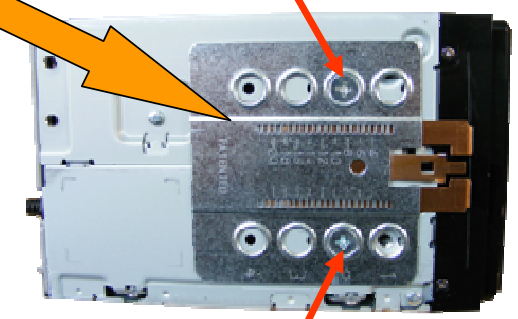
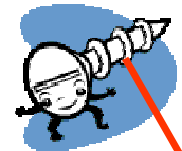
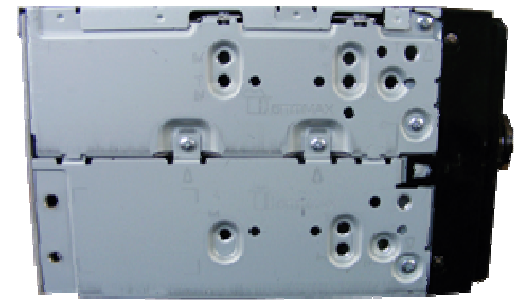
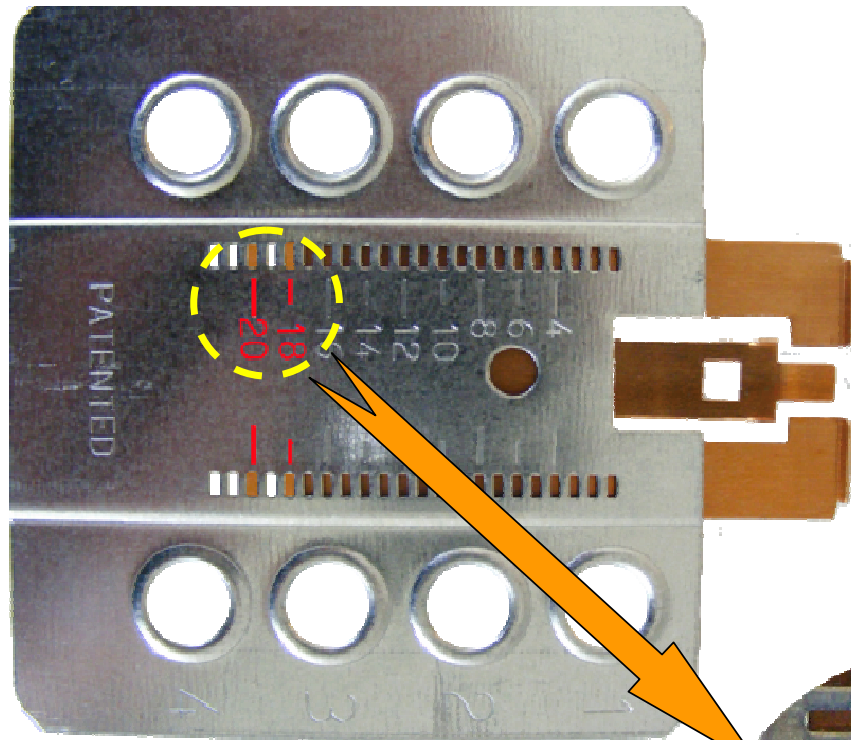



# *Fixation de l'autoradio et remontage des caches*



*Coller la mousse  
entre la ceinture métallique  
et la partie plastique de la  
voiture.*

*Positionner le cache plastique  
dans la ceinture métallique.*

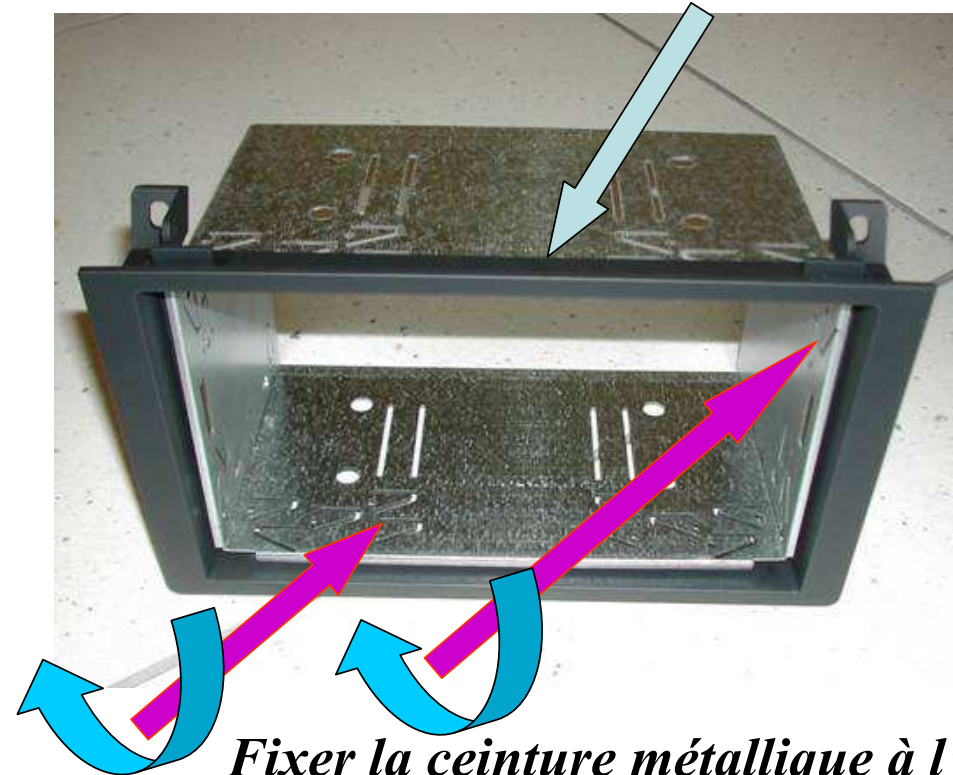

*Fixer la ceinture métallique à l'aide  
d'un tournevis pour tordre les pattes.*

# *Fixation de l'autoradio et remontage des caches*

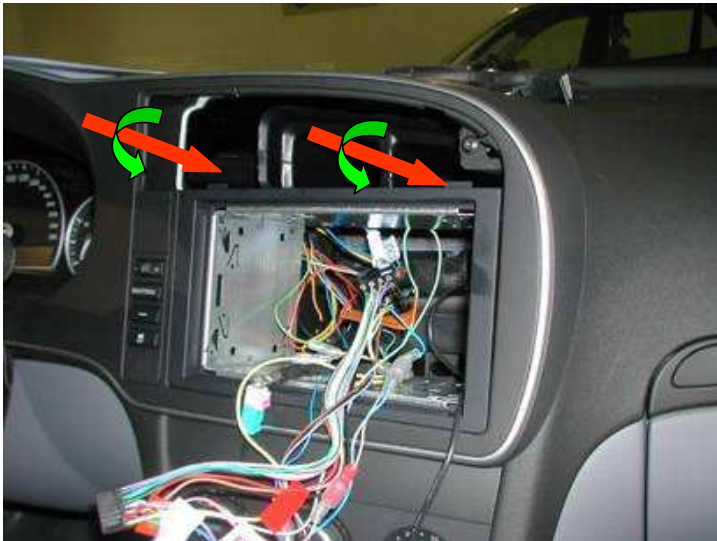

*Revisser le cadre plastique  
à l'aide des deux vis*

*Clipser l'enjoliveur*



*Glisser l'AVIC-F900BT  
dans la ceinture métallique*