

Installation Manual

2782A

2-DIN 381190-42-1

2-DIN with pocket 281190-42-1

2-DIN with Inbay-pocket 241190-42-1

Mercedes C-Class (W203) 05/2000 - 03/2004

Mercedes C-Class T-Model (S203) 01/2001 - 03/2004

Mercedes C-Class Coupé (CL203) 10/2000 - 03/2004

Mercedes CLK (C209) 06/2002 - 03/2004

Mercedes CLK (A209) Cabriolet 02/2003 - 03/2004

Mercedes Vito/Viano (W639/V639) 10/2003 - 03/2006

Compatible with double DIN devices

Double DIN Navigation

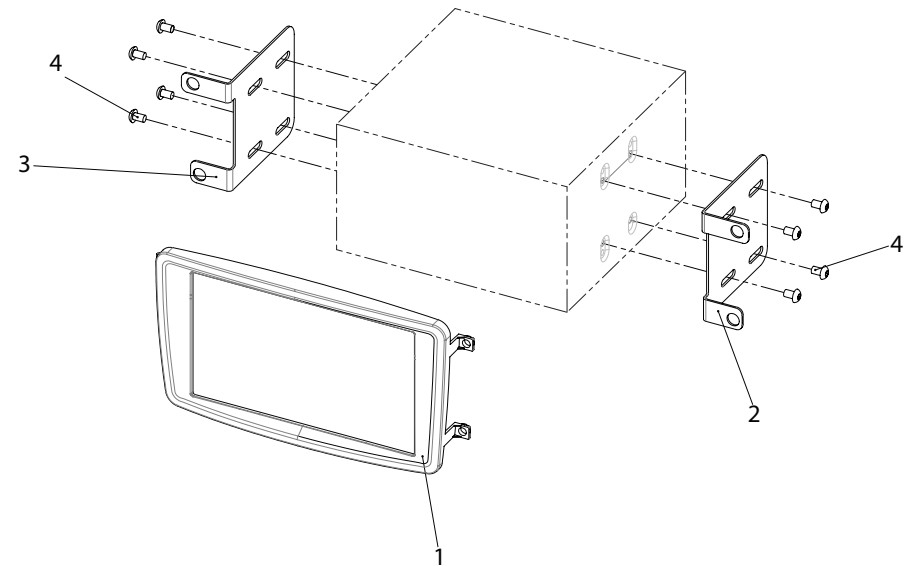

Double DIN Set contents

- (1) Facia Plate
- (2) Mounting Bracket left
- (3) Mounting Bracket right
- (4) Flat Headed Screw

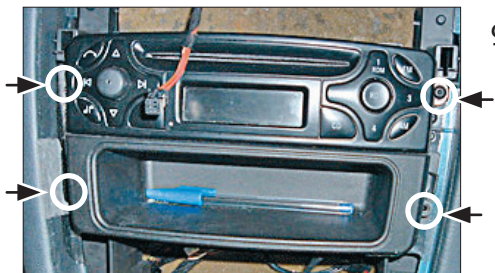

9. Remove four Torx screws (2 on each side) holding the OEM head unit.

Unplug all cables carefully
Remove OEM head unit.



11. Connect all required circuit points. Place head unit in dash board

Place fascia plate and fix it with the OEM screws (see step 9)

Reinstall everything in reverse order to finish installation

10. 2-DIN head unit install

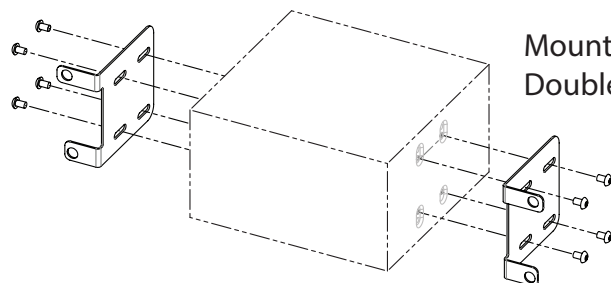

Mount mounting frames to Double-DIN head unit

1-DIN head unit install

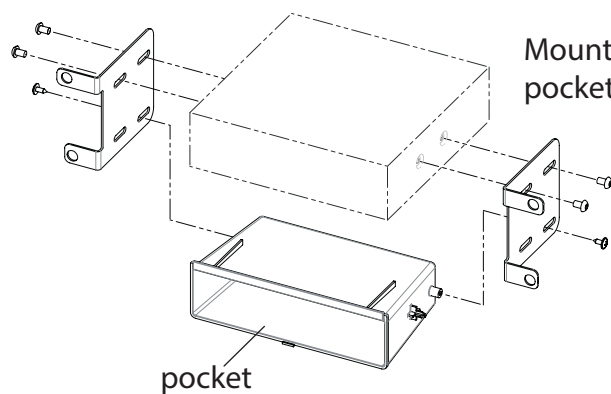

Mount mounting frames and pocket to 1-DIN head unit

pocket

*All installation work must be performed by a qualified professional installer only.
The manufacturer / dealer is not liable for any kind of incidental or indirect damages.*