

# *Guide de montage d'un système de navigation dans une Mercedes Classe A & B.*



## Pièces Pioneer

Kit 2 Din : Noir  
réf : 381190-18



## Interface électrique :

connecteur **ISO** réf : CTSM002PAE

ou

connecteur **Fakra** réf : CTSM001PAE

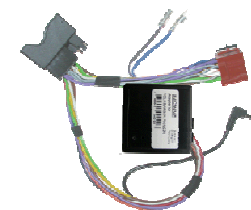

# *Dépose de l'autoradio d'origine*



*Sortir les grilles d'aération à l'aide  
des outils Mercedes  
Réf :140 589 02 33 00*





# *Dépose de l'autoradio d'origine*

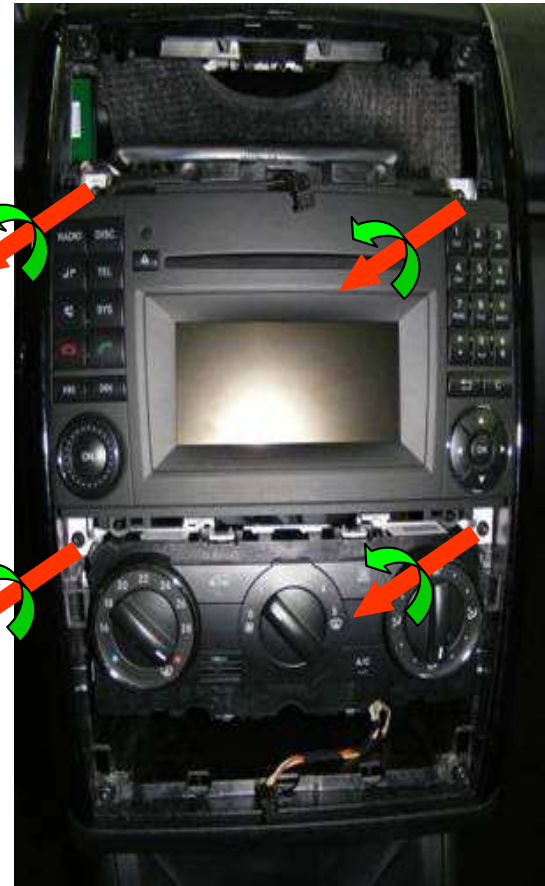
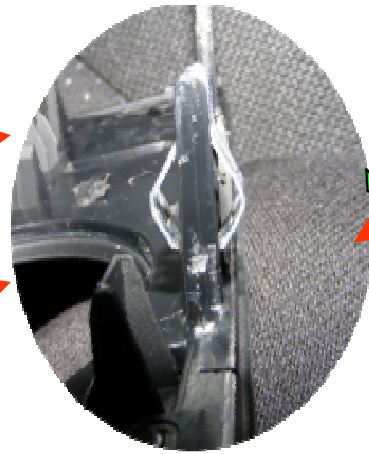
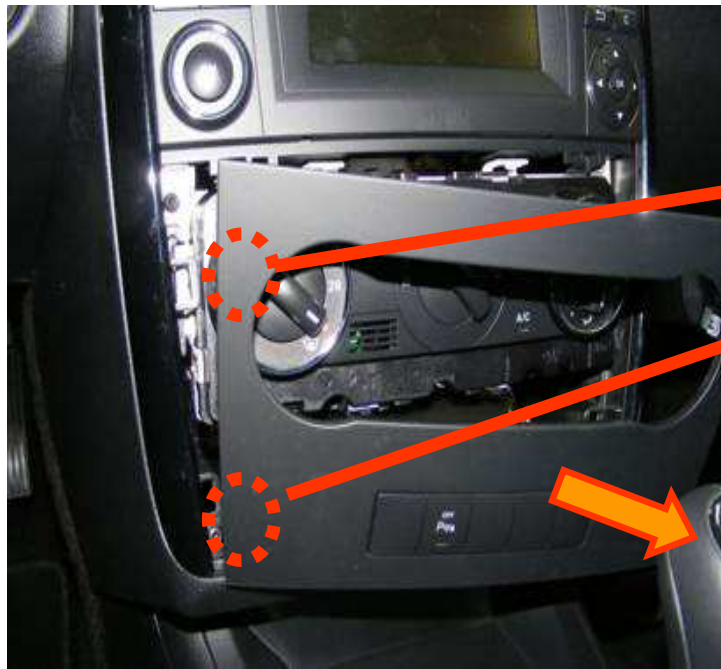

*Déconnecter et sortir  
l'autoradio*



*Dévisser les quatre  
visses de fixation de  
l'autoradio.*





# *Installation de l'antenne GPS.*



*Sortir le tableau d'instrument à l'aide des outils Mercedes  
Réf :140 589 02 33 00*

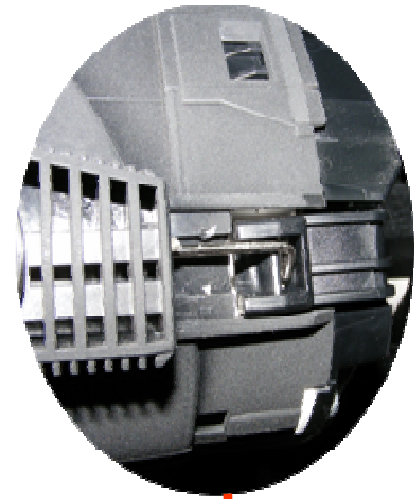
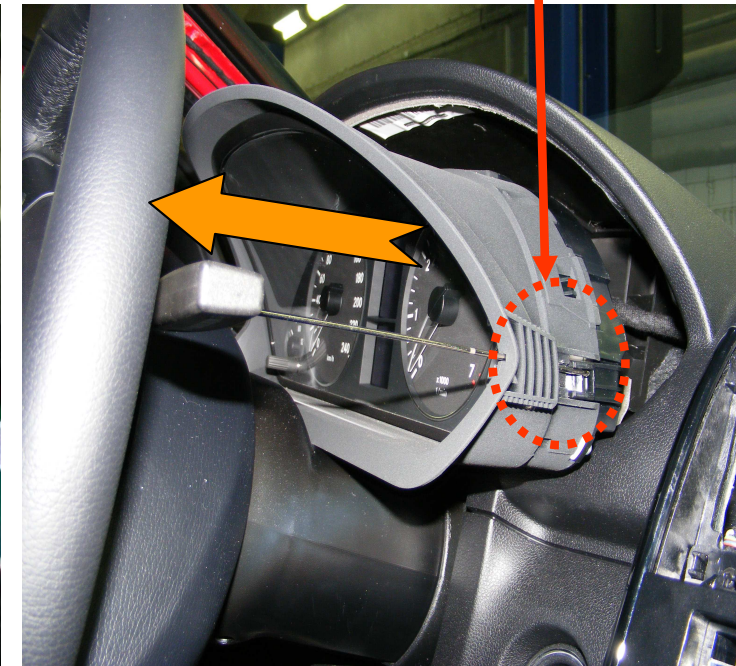
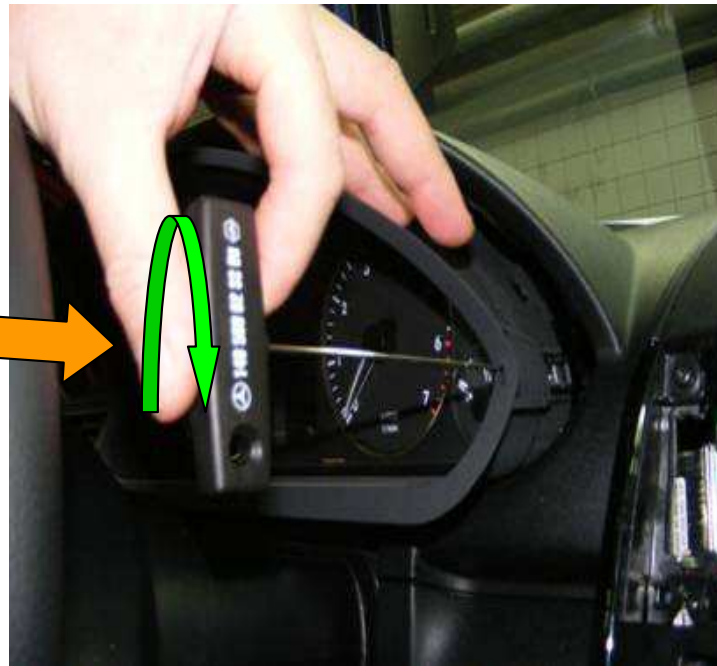

**Pioneer**  
CIP

# *Installation de l'antenne GPS.*

*Coller la plaque métallique sur le tableau d'instrument .*

*Poser l'antenne GPS sur la plaque métallique.*





# *Installation du micro.*



*Fixer le micro à l'aide  
de sa patte de  
fixation*

*Passage du câble  
du micro*



**Pioneer**  
**CIP**

# *Passages du câble micro.*

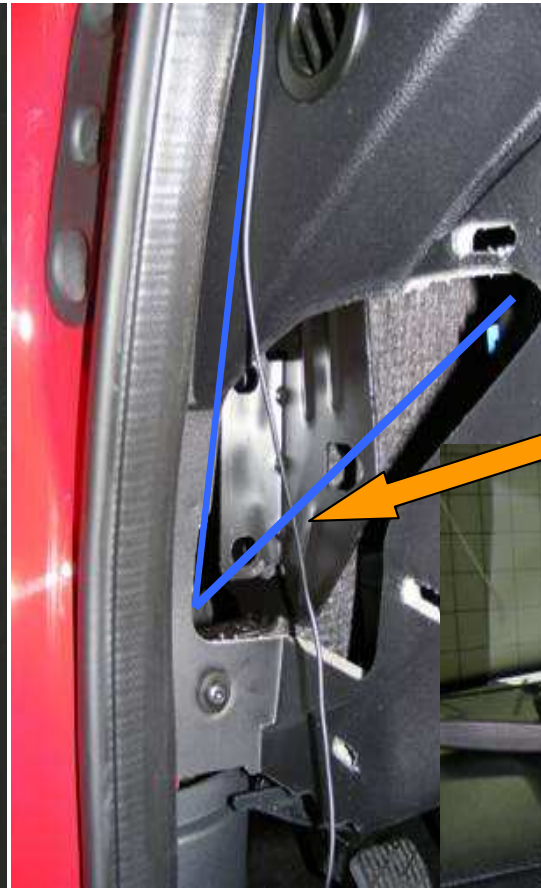

*Passage du câble  
du micro*

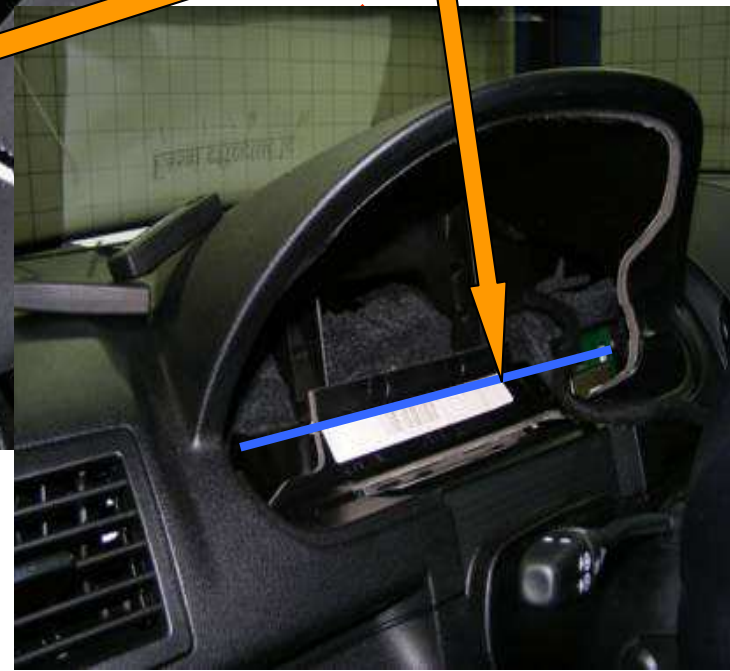

# *Connexions des fils*

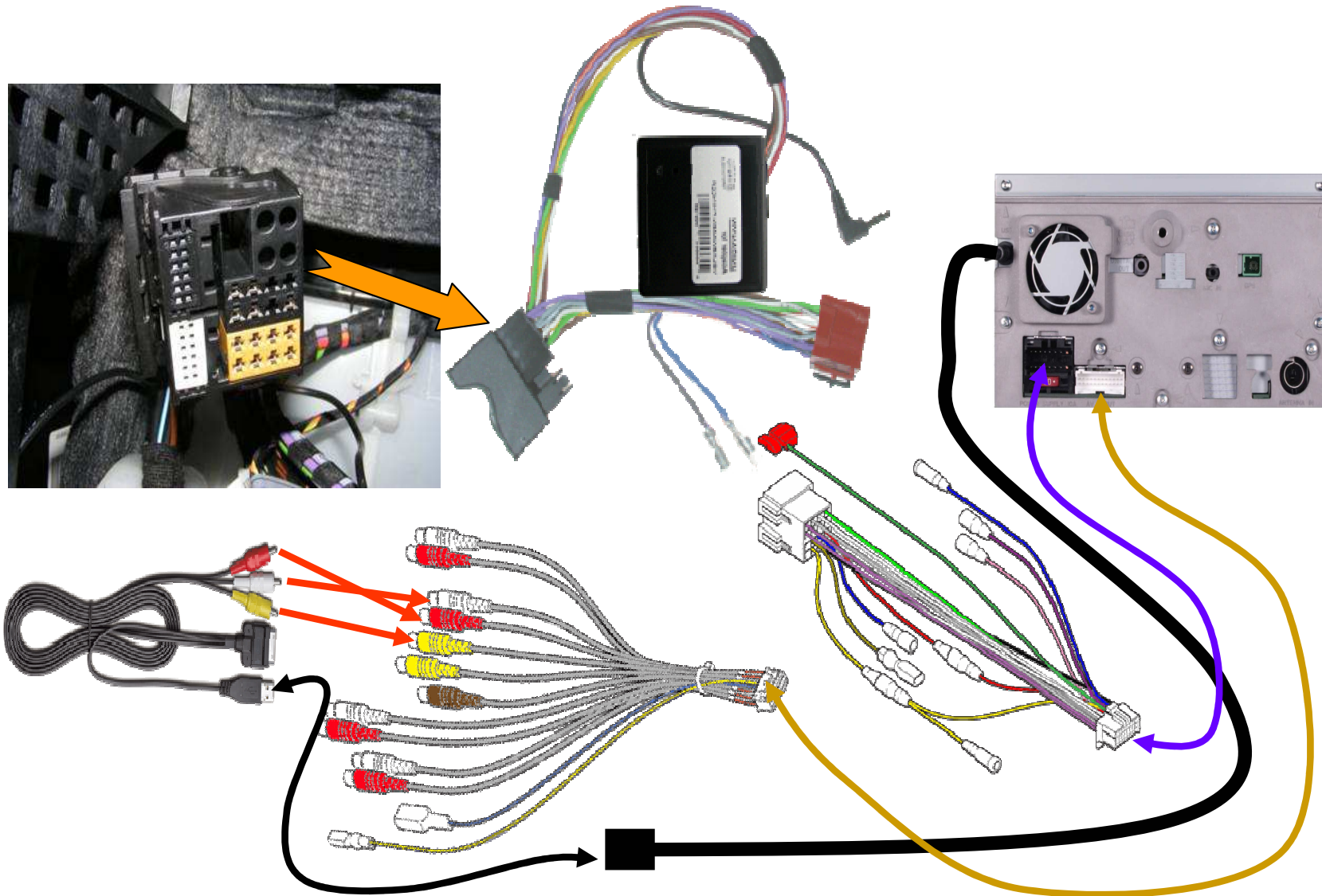



# Connexions des fils

**Signal marche arrière**  
Fil Violet/blanc de  
l'adaptateur avec le fil  
Violet/blanc Pioneer  
**REVERSE-GEAR SIGNAL  
INPUT**

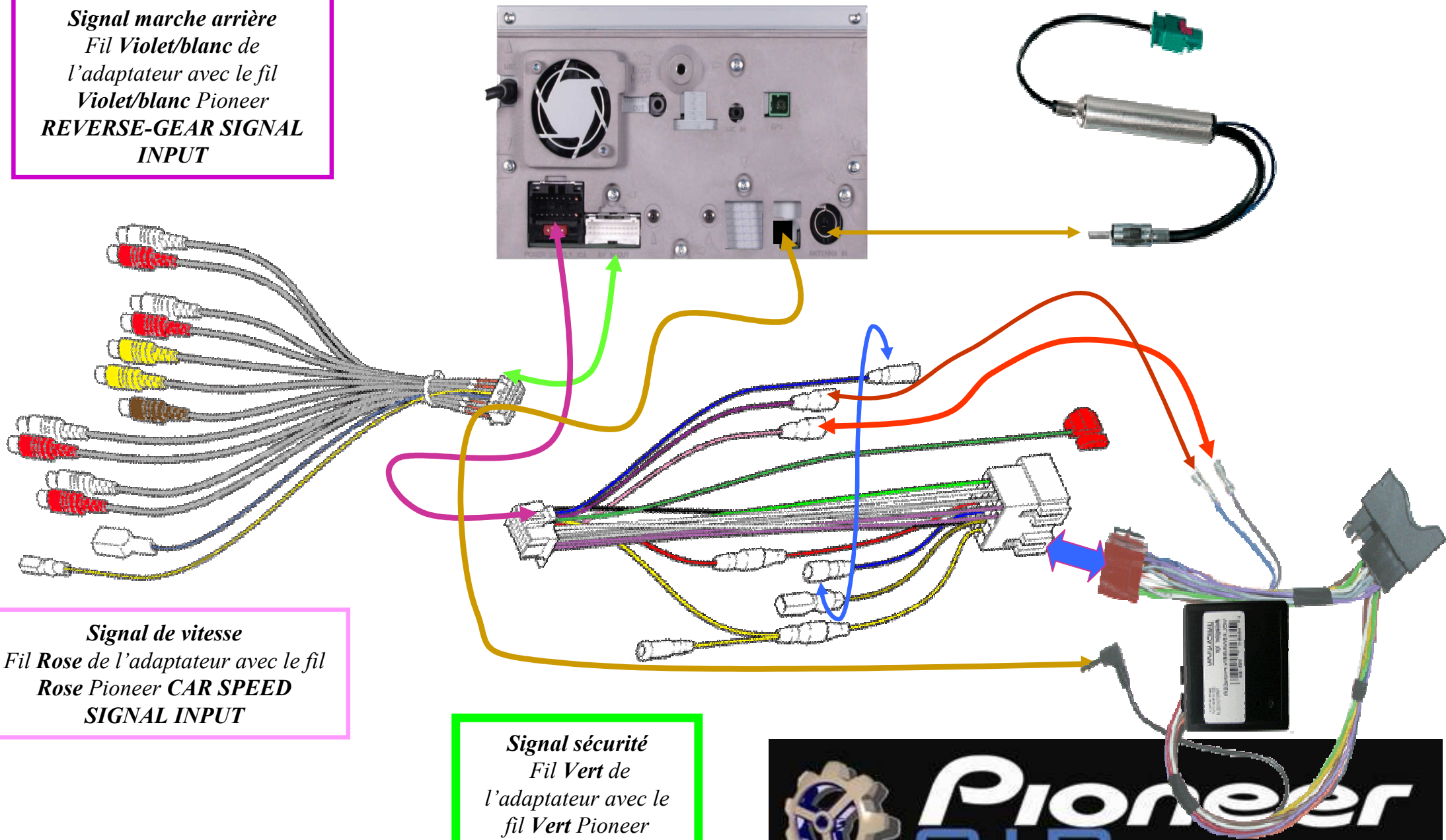

**Signal de vitesse**  
Fil Rose de l'adaptateur avec le fil  
Rose Pioneer **CAR SPEED  
SIGNAL INPUT**

**Signal sécurité**  
Fil Vert de  
l'adaptateur avec le  
fil Vert Pioneer  
**PARKING BRAKE**



# Démontage de l'autoradio.

- **Retirer le support.**

Dévisser les vis (3 mm × 6 mm) pour retirer le support.

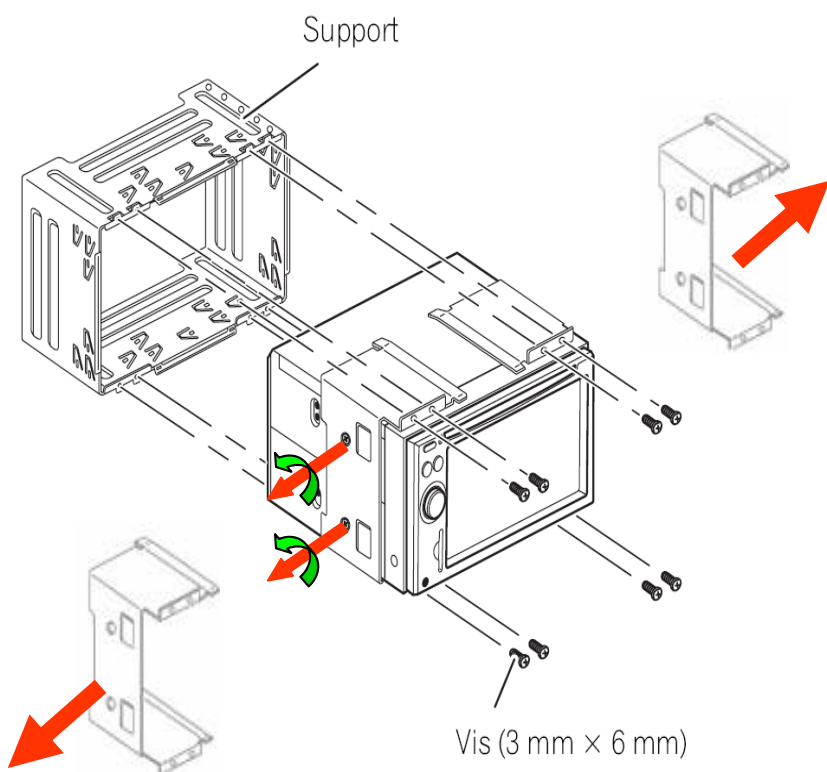



# *Démontage de l'autoradio.*

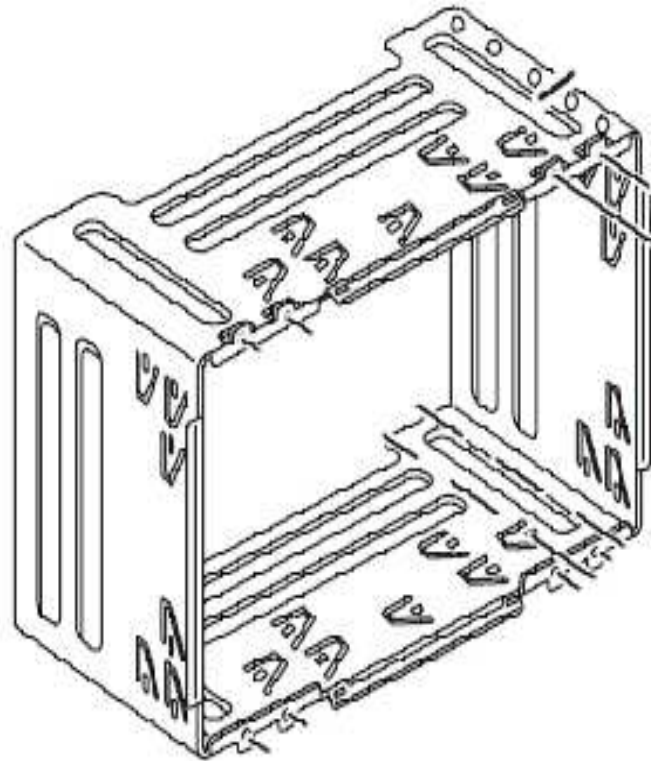
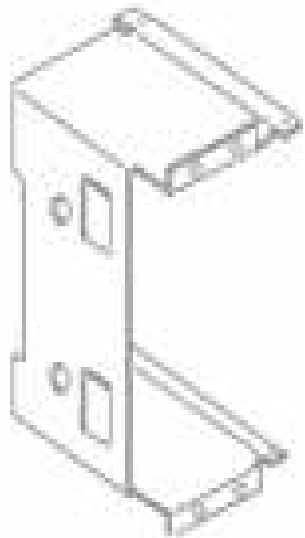
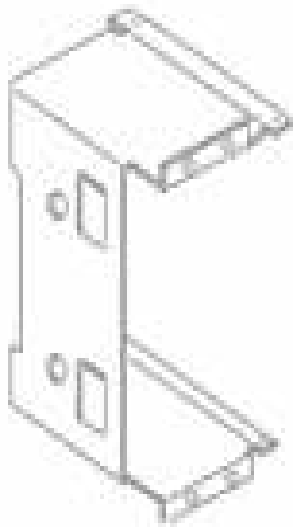

# Préparation de l'autoradio.

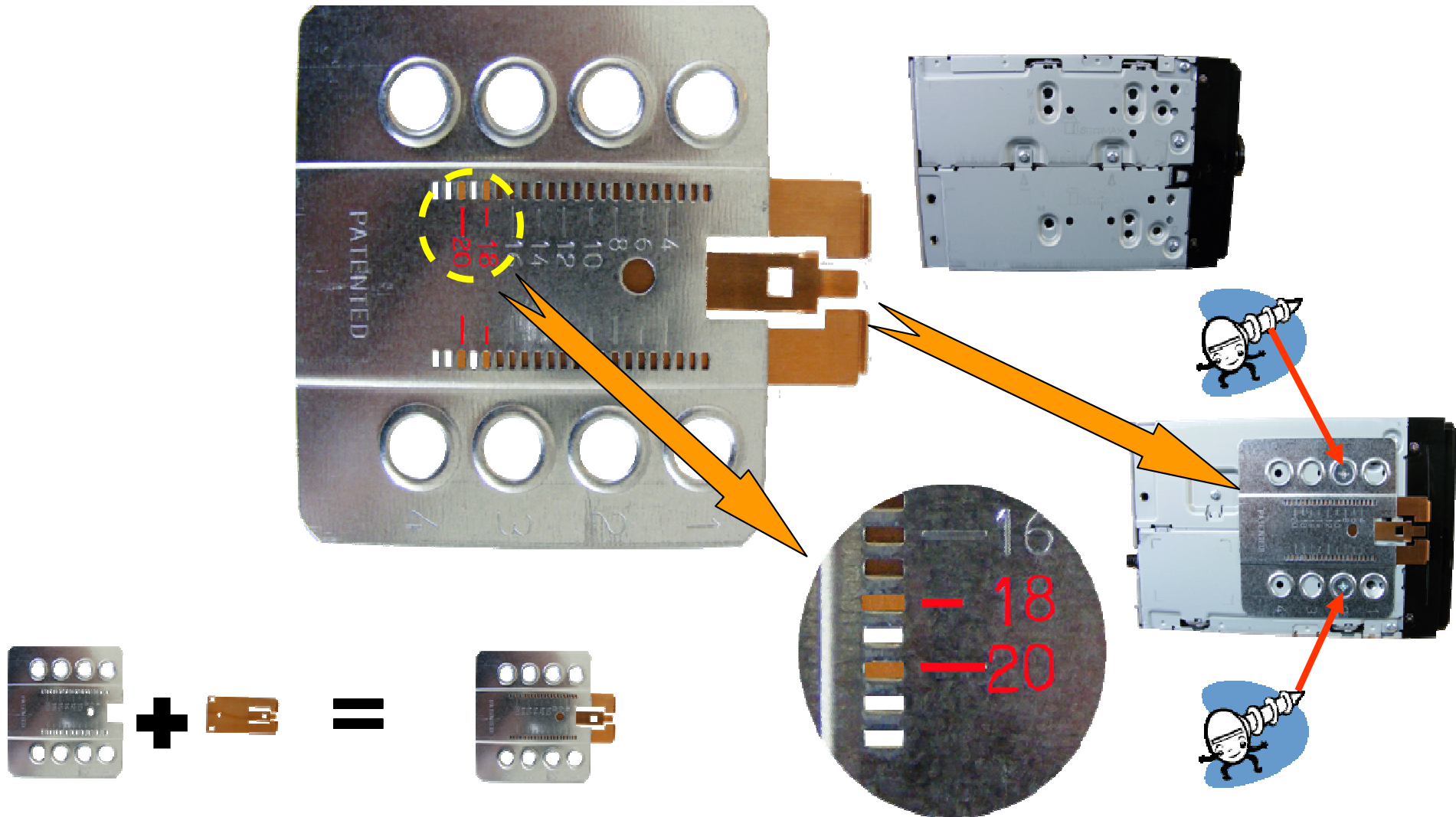



# *Fixation de l'autoradio.*

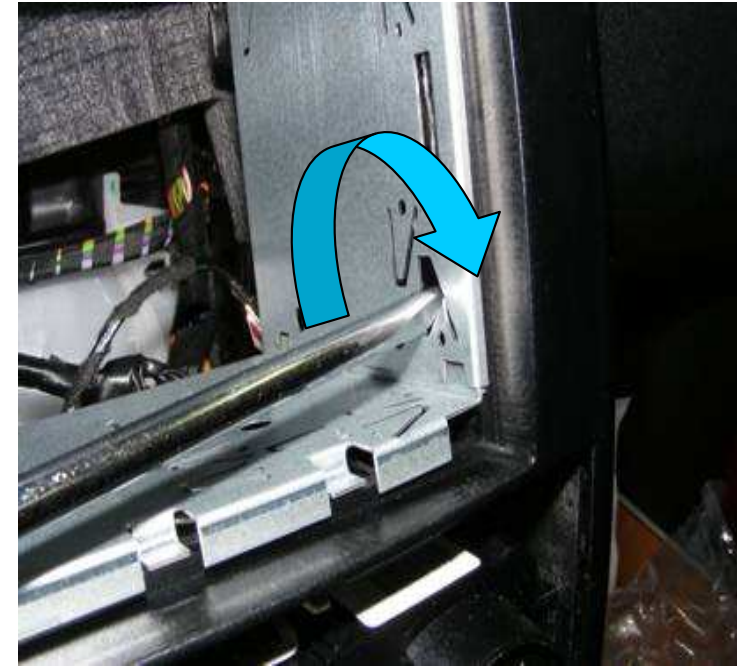
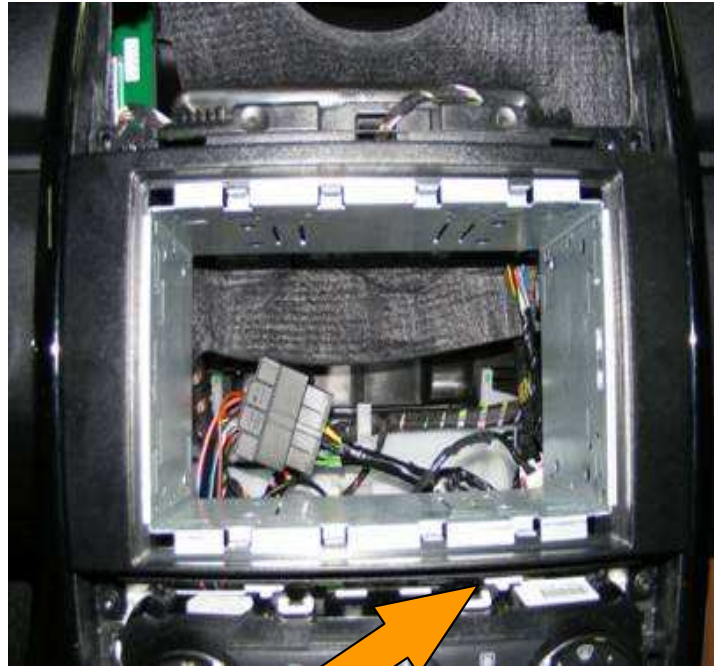
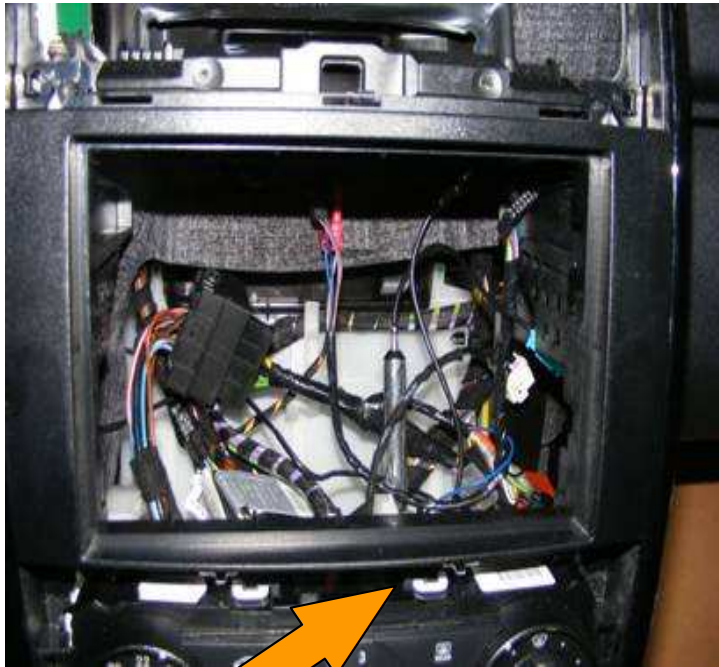

*Fixer la ceinture métallique à l'aide d'un tournevis pour tordre les pattes.*

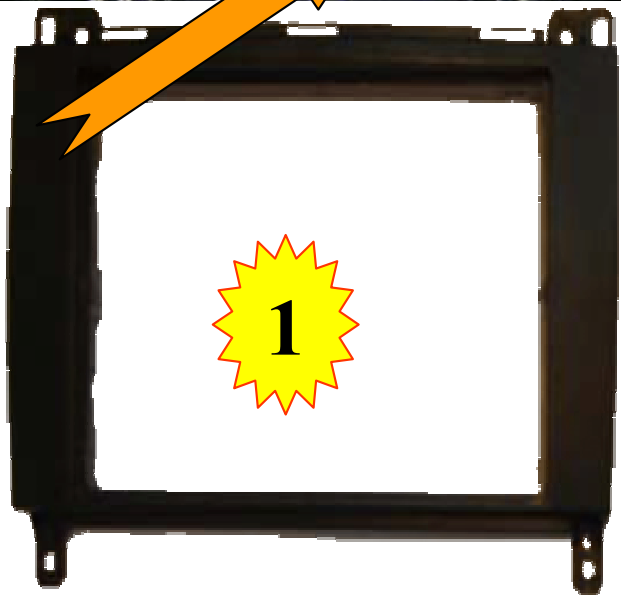

*Positionner le cache plastique.*

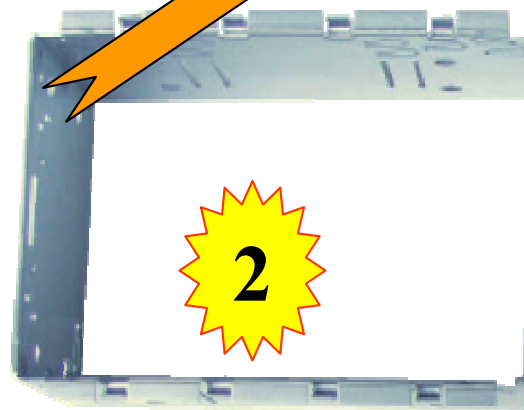

*Positionner la ceinture métallique dans le cache plastique.*



# Remontage des caches

*Fixer la ceinture métallique à l'aide d'un tournevis.*

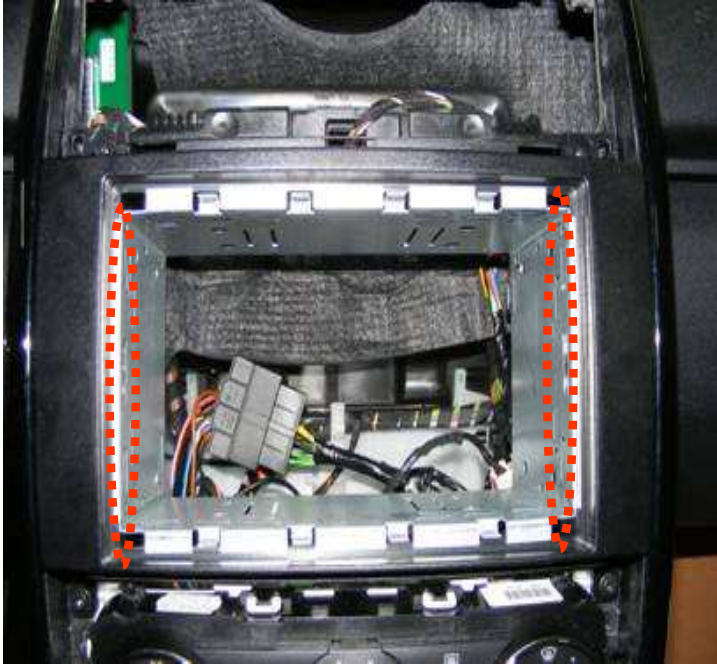

*Glisser le système de navigation dans la ceinture métallique*



*Clipser l'enjoliveur*

**3**

