



## INSTALLATION INSTRUCTIONS FOR PART 95-2009 or 99-2009

### APPLICATIONS

See application list inside

# GM/Suzuki multi-kit 1999-2011 95-2009 or 99-2009

### KIT FEATURES

95-2009:

- Double DIN radio provision
- Stacked ISO DIN radio provision

99-2009:

- DIN radio provision with pocket
- ISO DIN radio provision with pocket



### KIT COMPONENTS

95-2009: • A1) Double DIN trim plate • B1) Double DIN brackets • C1) Spacers • D1) (4) Carriage bolts  
• E1) (4) Kep nuts • F1) (3) Screws and (3) speed clips

99-2009: • A2) Radio housing • B2) Radio housing brackets • C2) Trim plate • D2) ISO brackets  
• E2) DIN spacer • F2) (4) Carriage bolts • G2) (4) Kep nuts • H2) (3) Screws & (3) Speed clips  
• I2) (2) #8 3/8" Phillips screws

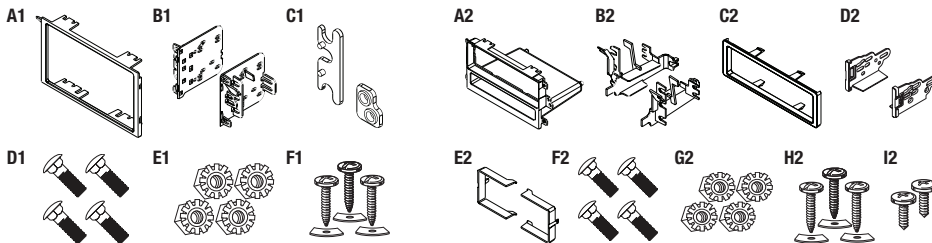

### WIRING & ANTENNA CONNECTIONS (sold separately)

Wiring Harness:

- Visit [www.metraonline.com](http://www.metraonline.com) for specific interface applications

Antenna Adapter:

- 40-GM10 - GM antenna adapter 1988-up
- 40-CR10 - Chrysler antenna adapter 2002-up

### TOOLS REQUIRED

- Utility knife • Phillips screwdriver • Socket set

**CAUTION:** Metra recommends disconnecting the negative battery terminal before beginning any installation. All accessories, switches, and especially air bag indicator lights must be plugged in before reconnecting the battery or cycling the ignition.

**NOTE:** Refer to the instructions included with the aftermarket radio.

REV. 9/19/2013 INST-2009



INST-2009

## Applications

### Buick

Century.....	1997-2005
LeSabre.....	1995-2005
Park Avenue.....	1995-2005
Rainier.....	2004-2007
Regal.....	1995-2004
Rendezvous.....	2002-2007
Riviera.....	1996-1999
Roadmaster.....	1995-1996
Skylark.....	1996-1998

### Cadillac

Escalade ESV/EXT.....	2003-2006
Brougham.....	1990-1996
Eldorado.....	1992-1995
Fleetwood.....	1990-1996
Seville.....	1992-1995

### Chevrolet

Avalanche.....	2003-2006
Blazer (with DDIN).....	2002-2005
Cavalier.....	2000-2005

### Chevrolet (continued)

Colorado.....	2004-2012
Express Van (full).....	2001-2007
Impala.....	2000-2005
Kodiak.....	2003-2009
Malibu.....	2001-2003
Malibu Classic.....	2004
Metro/Geo.....	1995-2001
Monte Carlo.....	2000-2005
SSR.....	2003-2006
S-10 Pickup (with DDIN) ..	2002-2004
Silverado.....	2003-2006
Silverado Classic.....	2007
Suburban.....	2003-2006
Tahoe.....	2003-2006
Tracker.....	1992-2004
Trailblazer.....	2002-2009
Venture.....	2000-2005

### GMC

Canyon.....	2004-2012
-------------	-----------

### GMC (continued)

Envoy.....	2002-2009
Savana.....	2001-2007
Sierra.....	2003-2006
Sierra Classic.....	2007
Sonoma (with DDIN).....	2002-2004
Top Kick.....	2005-2009
Yukon/Denali/XL.....	2003-2006

### Honda

Passport.....	1998-2002
---------------	-----------

### Hummer

H2.....	2003-2007
---------	-----------

### Isuzu

Ascender.....	2003-2009
Amigo.....	1998-2000
i290/i370.....	2007-2008
i280/i350.....	2006
Rodeo.....	1998-2004
Rodeo Sport.....	2001-2003

### Oldsmobile

Achieva.....	1996-1998
Alero.....	1999-2004
Aurora.....	1995-2003
Bravada.....	1998-2001
Bravada.....	2002-2004
Cutlass.....	1997-1999
Cutlass Supreme.....	1995-1997
Eighty-Eight.....	1994-1999
Intrigue.....	1998-2003
LSS.....	1996-1999
Ninety-Eight.....	1994-1996
Regency.....	1997-1998
Silhouette.....	2000-2004

### Pontiac

Aztec.....	2001-2005
Bonneville.....	2000-2005
Grand Am.....	2001-2005
Montana.....	2000-2005
Sunfire.....	2000-2005

### Suzuki

Aerio.....	2002
Esteem.....	1995-2003
Sidekick.....	1992-1998
Swift.....	1995-2001
Vitara.....	1999-2005
Grand Vitara.....	1999-2002
XL-7.....	2001-2002

### Toyota

Matrix.....	2003-2004
-------------	-----------



INST-2009

## Table of Contents

### Dash Disassembly

- Buick Century 1997-2005/ Regal 1995-2004.....	4
- Buick LeSabre/Park Avenue 1995-1999.....	4
- Buick LeSabre/Park Avenue 2000-2005.....	4
- Buick Rendezvous 2002-2007.....	5
- Buick Riviera 1996-1999.....	5
- Buick Roadmaster 1995-1996.....	10
- Buick Skylark 1996-1998.....	6
- Cadillac Eldorado/Seville 1992-1995.....	7
- Cadillac Escalade ESV/EXT/Chevrolet Avalanche/Suburban/Tahoe 2003-2006.....	6
- Cadillac Fleetwood/ Brougham 1990-1996.....	6-7
- Chevrolet Blazer 2002-2005.....	8
- Chevrolet Cavalier 2000-2005.....	8
- Chevrolet Colorado 2004-2012/ GMC Canyon 2004-2012.....	9
- Chevrolet Express Van/ GMC Savana 2001-2002.....	9
- Chevrolet Express Van/ GMC Savana 2003-2007.....	10
- Chevrolet Impala 2000-2005.....	10
- Chevrolet Malibu 2001-2003/ Malibu Classic 2004.....	11

- Chevrolet Metro/ Suzuki Swift 1995-2001.....	11
- Chevrolet Monte Carlo 2000-2005.....	11
- Chevrolet S-10 (with DDIN)/ GMC Sonoma (with DDIN) 2002-2004.....	8
- Chevrolet Silverado/GMC Sierra 2003-2006, Chevrolet Silverado Classic/GMC Sierra Classic 2007, Chevrolet Kodiak 2003-2009.....	6
- Chevrolet SSR 2003-2006.....	12
- Chevrolet Tracker 1992-2004/Suzuki Sidekick 1992-1998/Vitara 1999-2005...	12
- Chevrolet Trailblazer 2002-2009.....	13
- Chevrolet Venture/Oldsmobile Silhouette/ Pontiac Montana (except SV6) 2000.....	13
- Chevrolet Venture/Pontiac Montana (except SV6) 2001-2005.....	13
- GMC Envoy 2002-2009/ Isuzu Ascender 2003-2009.....	14
- GMC Top Kick, Yukon/Denali/XL 2003-2006.....	6
- Honda Passport 1998-2002.....	18
- Hummer H2 2003-2007.....	14-15
- Isuzu i290/i370 2007-2008.....	9
- Isuzu i280/i350 2006.....	9

- Isuzu Amigo 1998-2000/Rodeo 1998-2004/Rodeo Sport 2001-2003.....	18
- Oldsmobile Achieva 1996-1998.....	15
- Oldsmobile Alero 1999-2004.....	16
- Oldsmobile Aurora 1995-2003.....	16
- Oldsmobile Bravada 1998-2004/ Buick Rainier 2004-2007.....	14
- Oldsmobile Bravada 1998-2001.....	8
- Oldsmobile Cutlass 1997-1999/ Cutlass Supreme 1995-1997.....	16
- Oldsmobile Eighty Eight 1994-1999.....	17
- Oldsmobile Ninety Eight 1994-1996.....	17
- Oldsmobile Intrigue 1998-2003.....	17
- Oldsmobile LSS 1996-1999/ Regency 1997-1998.....	18
- Oldsmobile Silhouette 2001-2004.....	13
- Pontiac Aztec 2001-2005.....	19
- Pontiac Bonneville 2000-2005.....	19
- Pontiac Grand Am 2001-2005.....	20
- Pontiac Sunfire 2000-2005.....	20
- Suzuki Aerio 2002.....	21
- Suzuki Esteem 1995-2003.....	21
- Suzuki Grand Vitara 1999-2002/ XL-7 2001-2002.....	12

- Toyota Matrix 2003-2004/ Pontiac Vibe 2003-2008.....	21
---	----

### Tab Instruction

#### 95-2009:

- Cadillac/Chevy/GMC/Isuzu/Metro/ Pontiac/Suzuki/Toyota.....	22-23
---	-------

#### 95-2009:

- Cadillac/Chevy/GMC/Isuzu/Metro/ Pontiac/Suzuki/Toyota.....	26-27
---	-------

### Kit Assembly

#### 95-2009:

- Cadillac Fleetwood/Brougham 1990-1996 (assembly with brackets).....	24
- Cadillac Eldorado/Seville 1992-1995.....	24
- Double DIN radio/Stacked ISO mount unit provision.....	25

#### 99-2009:

- Cadillac Fleetwood/Brougham 1990-1996 (assembly with brackets).....	28
- Cadillac Eldorado/Seville 1992-1995.....	28
- ISO mount radio provision with pocket....	29
- DDIN radio provision with pocket.....	30-31



## Dash Disassembly

### Buick Century 1997-2005 Regal 1995-2004

1. Remove the plastic trim piece to the left of the glove box and the (1) exposed Phillips screw.
  2. Unsnap the top edge of the knee bolster panel.
  3. Remove (1) Phillips screw from the panel.
  4. Remove the ashtray cluster and (2) Phillips screws from each side.
  5. Unclip the entire dash trim bezel and remove. (Figure A)
  6. Open doors and unsnap end caps from each side of dash.
  7. Unsnap and remove radio/instrument cluster panel.
  8. Remove (3) screws in order to remove radio.
- Continue to tab instructions*

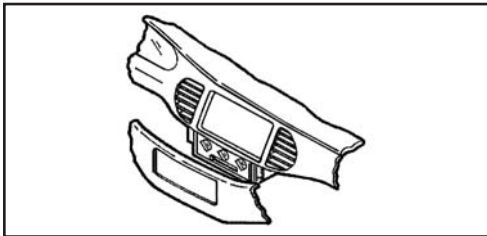

(Figure A)

### Buick LeSabre/Park Avenue 1995-1999

1. Unsnap the climate control trim panel (from door to door) and remove (4) Phillips screws exposed.
2. Pop out the A/C vents and remove (1) Phillips screw exposed in each vent cavity.
3. Unclip the radio trim bezel and remove.
4. Remove the screws securing the factory head unit and disconnect the wiring.

*Continue to tab instructions*

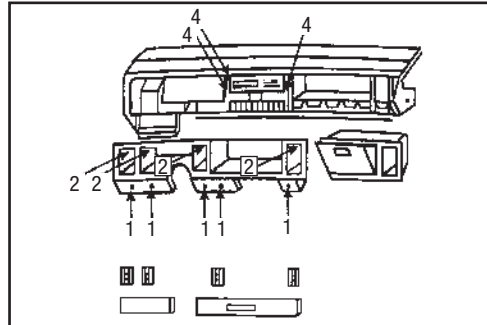

### Buick LeSabre/Park Avenue 2000-2005

1. Open driver's door and unsnap and remove dash end cap.
2. Unsnap and remove trim along center of dash (one piece on right and one on left of wheel).
3. Unsnap and remove radio/instrument bezel. (Figure A)
4. Remove (2) screws in order to remove radio.

*Continue to tab instructions*

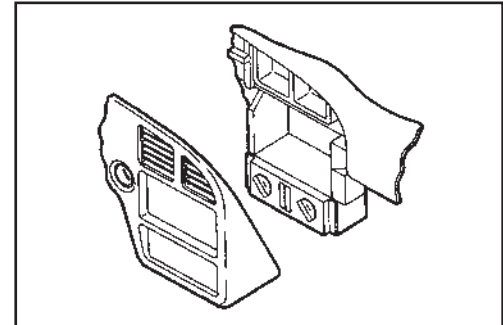

(Figure A)



## Dash Disassembly

### Buick Rendezvous 2002-2007

1. Open center console and remove (2) screws at front of console opening. (Figure A)
  2. Remove liners from cup holders and storage pocket next to cup holders, then remove screws. Unsnap and remove panel. (Figure B)
  3. Remove (2) screws from bottom of radio/climate control bezel, unclip and remove. (Figure C)
  4. Remove (3) 9/32" hex head screws to remove radio. (Figure D)
- Continue to tab instructions*

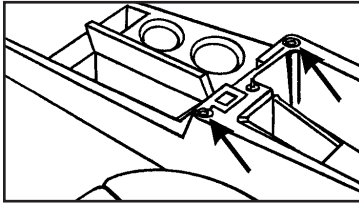

(Figure A)

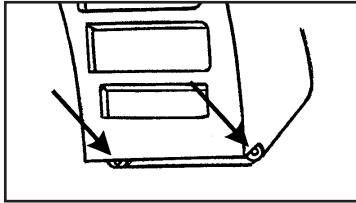

(Figure C)

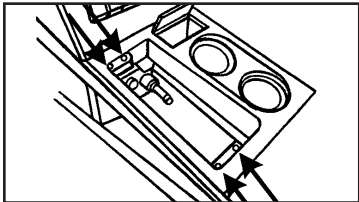

(Figure B)

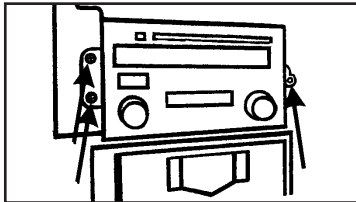

(Figure D)

### Buick Riviera 1996-1999

1. Unsnap left side panel exposing (1) Phillips screw beneath panel and remove. (Figure A)
2. Unsnap right side panel to expose (1) Phillips screw beneath panel and remove. (Figure A)
3. Unsnap underside of overhanging dash to unsnap (6) plastic rivets and remove panel. (Figure A)
4. Remove (5) hex head screws exposed under overhang. (Figure B)
5. Unsnap bottom edge of trim bezel then, while holding overhang up, unsnap and remove trim bezel by removing any necessary harnesses.
6. Remove (3) Phillips screw to remove climate control.
7. Remove (2) Phillips screws to remove rear support and (3) 9/32" hex head screws to remove radio.

*Continue to tab instructions*

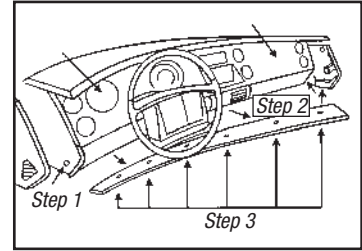

(Figure A)

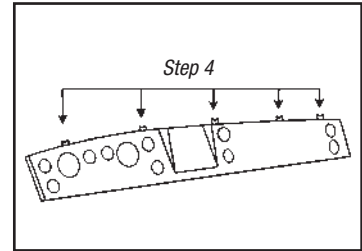

(Figure B)



## Dash Disassembly

### Buick Skylark 1996-1998

1. Remove (6) 9/32" screws inside glove box.
2. Under glove box and drivers knee bolster remove (2) plastic panels by turning the (2) 1/4-turn fasteners per side.
3. Remove the (4) 9/32" screws revealed (2 per side).
4. Unsnap panel from driver's side to passenger's side.
5. Remove (3) 9/32" screws to remove radio.  
*Continue to tab instructions*

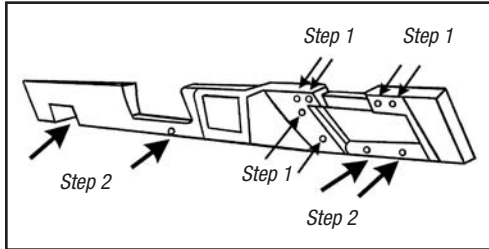
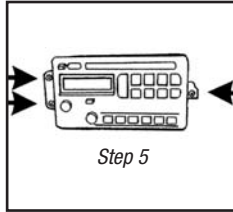

### Cadillac Escalade ESV/EXT/ Chevrolet Avalanche/Suburban/ Tahoe 2003-2006, Chevrolet Kodiak 2003-2009, Chevrolet Silverado/GMC Sierra 2003-2006, Chevrolet Silverado Classic/GMC Sierra Classic 2007, GMC Top Kick 2005-2009, GMC Yukon/ Denali/XL 2003-2006

1. Unsnap and remove dash bezel. (Figure A)
2. Remove (3) 9/32" screws and remove radio.

*Continue to tab instructions*

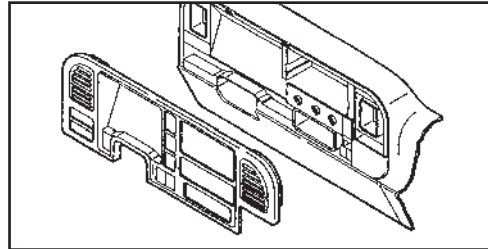

(Figure A)

### Cadillac Fleetwood/ Brougham 1990-1996

1. Carefully unsnap trim panel above A/C controls. (Figure A)
2. Remove (2) 7mm screws at the top of the radio/air conditioning bezel, then unclip panel and remove. (Figure B & C)
3. Remove (4) 7mm screws that hold the radio in, slide radio out, unplug the radio harnesses and remove radio. (Figure D)

*Continue to Radio Bracket Disassembly (pg. 7)*

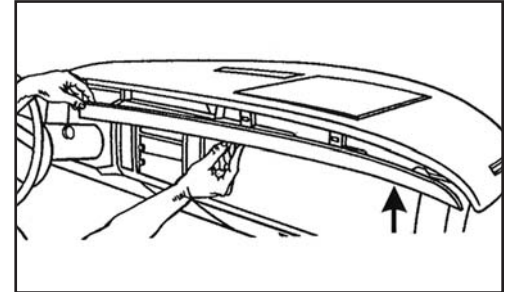

(Figure A)



## Dash Disassembly

### Cadillac Fleetwood/ Brougham 1990-1996

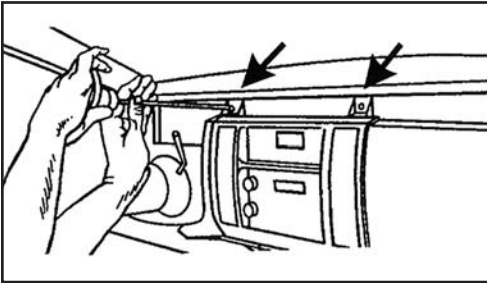

(Figure B)

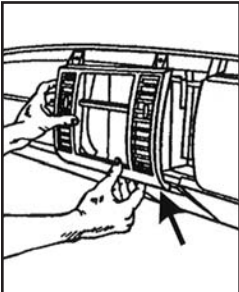

(Figure C)

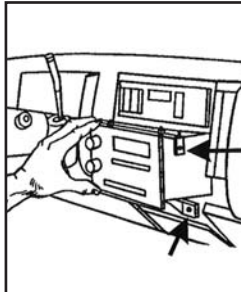

(Figure D)

### Cadillac Fleetwood/ Brougham 1990-1996 Radio Bracket Disassembly

1. Remove (4) 10mm nuts, (2) on top of the radio and (2) on the bottom of the radio, that hold the factory mounting brackets on.
2. Save brackets and nuts for kit assembly.

*Continue to tab instructions*

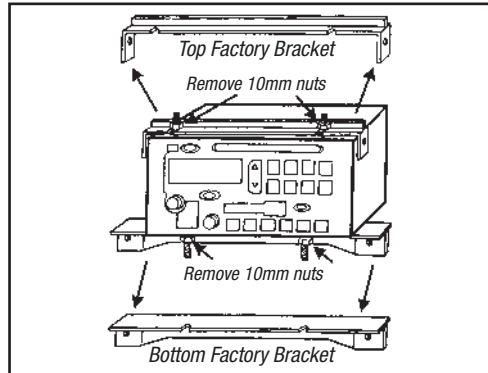

### Cadillac Eldorado/Seville 1992-1995

1. Using a panel removal tool pry out on the radio trim ring and remove.  
**Caution:** *Use extreme care when removing.*
2. Gently pry up on the ashtray/gear shifter trim bezel and remove. (Figure A)  
**Note:** *Some models are equipped with bezels made of real wood.*
3. Remove (2) nuts securing the bottom of the factory head unit and disconnect the wiring.

*Continue to tab instructions*

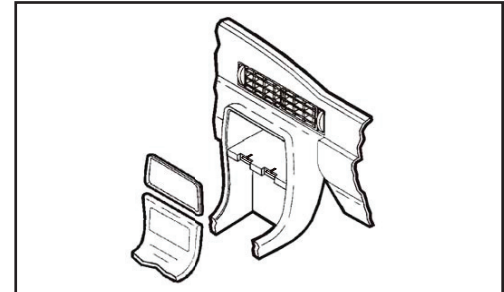

(Figure A)



## Dash Disassembly

### **Chevrolet Blazer (with DDIN) 2002-2005, Chevrolet 5-10 (with DDIN)/GMC Sonoma (with DDIN) 2002-2004, Oldsmobile Bravada 1998-2001**

1. Remove (2) 9/32" hex head screws from the knee bolster panel.
2. Pull down on the panel and remove the 9/32" hex head screws exposed on the bottom of the dash trim bezel.
3. Remove (1) Phillips screw above the instrument cluster.
4. Unclip the dash trim bezel and remove. (Figure A)
5. Remove (2) 9/32" hex head screws securing the factory head unit and disconnect the wiring.

*Continue to tab instructions*

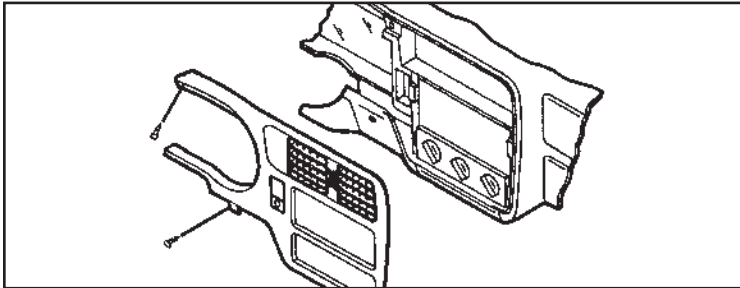

(Figure A)

### **Chevrolet Cavalier 2000-2005**

1. Open drivers door and remove fuse panel on end of dash.
2. Open passenger door and remove panel on end of dash.
3. Remove (1) Phillips screw from each side exposed.
4. Remove (3) screws from top of glove box liner.
5. Remove (2) screws from the top-left corner of the glove box cavity.
6. Remove (1) Phillips screw from the defroster duct.
7. Remove the ductwork and (1) Phillips screw exposed.
8. Remove the dash pad and (3) Phillips screws exposed at the top of the radio trim bezel.

*Continue to tab instructions*

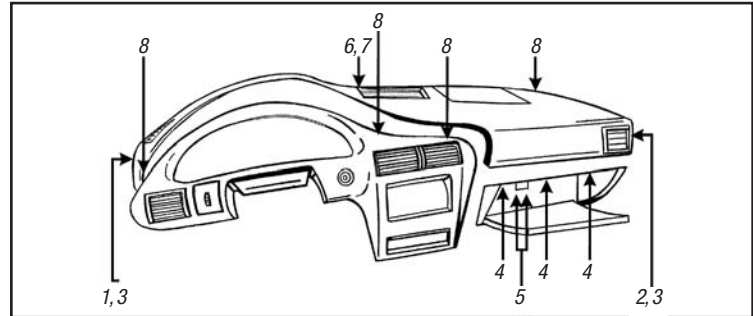





## Dash Disassembly

### Chevrolet Colorado 2004-2012, GMC Canyon 2004-2012, Isuzu i290/i370 2007-2008, Isuzu i280/i350 2006

1. Unsnap and remove the entire panel surrounding the radio and A/C controls. (Figure A)
2. Remove (3) 9/32" screws securing the radio to remove. (Figure B)

*Continue to tab instructions*

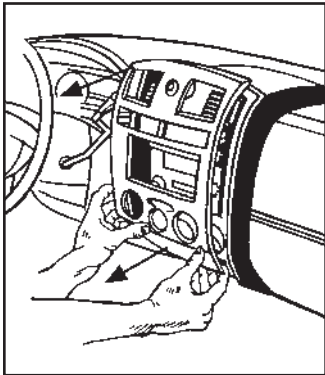

(Figure A)

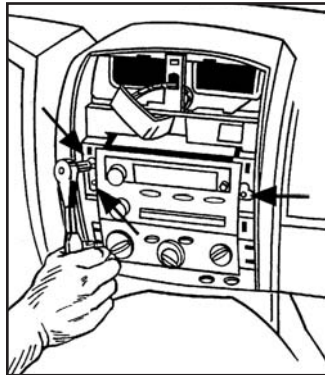

(Figure B)

### Chevrolet Express Van/GMC Savana 2001-2002

1. Unsnap and remove small trim panel below steering column. (Figure A)
2. Unsnap radio/climate/instrument panel. (Figure B)
3. Move shift lever to first gear position.
4. Rotate panel counterclockwise to lift over steering column and remove.
5. Remove (3) 9/32" hex head screws to remove radio. (Figure C)

*Continue to tab instructions*

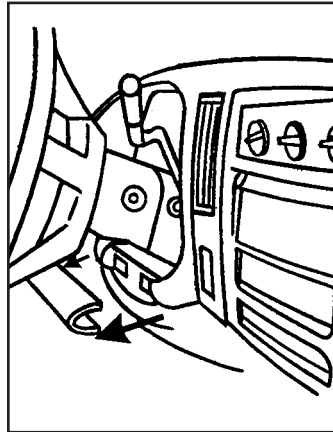

(Figure A)

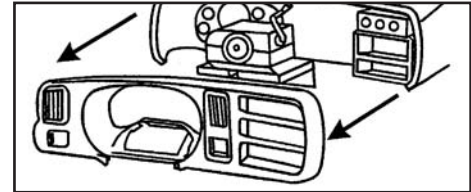

(Figure B)

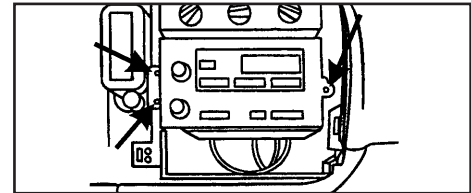

(Figure C)



## Dash Disassembly

### Chevrolet Express Van/ GMC Savana 2003-2007

1. Remove (2) 10mm bolts from below knee bolster under steering column and remove panel.
2. Remove (2) 10mm bolts from panel below passenger dash airbag and remove panel.
3. Remove (2) 10mm nuts from inside center pocket between power outlets.
4. Unsnap and remove radio and instrument cluster panel.  
**Note:** *it may not be necessary to completely remove radio and instrument cluster panel to access radio.*
5. Remove (3) 9/32" bolts to remove radio.  
*Continue to tab instructions*

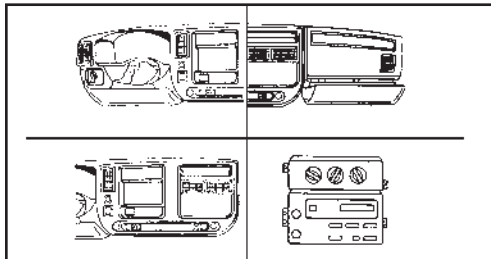

### Buick Roadmaster 1995-1996

1. Unclip dash panel sides and remove.
2. Unclip panel below steering column and remove.
3. Remove (2) 7mm screws above instrument cluster.
4. Set parking brake, turn key to on position, and move shifter to the lowest gear. Tilt steering wheel down then unclip entire instrument cluster/radio panel and remove. Return shifter to park.
5. Remove (3) 7mm screws to remove radio.

*Continue to tab instructions*

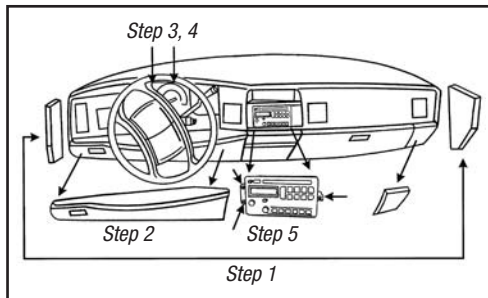

### Chevrolet Impala 2000-2005

1. Unclip each side of the dash trim bezel (fuse access) and remove (1) Phillips screw exposed on each side.
2. Remove (2) Phillips screws under the instrument cluster.
3. Unclip the trim panel above the pedals. It is not necessary to remove the panel it can be left hanging.
4. Remove (2) Phillips screws from the knee panel.
5. Unclip the knee panel and remove (1) Phillips screw exposed on the right side of the steering column.
6. Unclip and remove the entire dash trim bezel. (Figure A)  
*Continue to tab instructions*

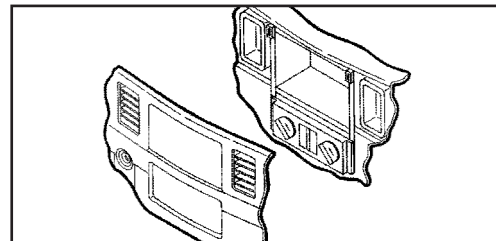

(Figure A)



## Dash Disassembly

### Chevrolet Malibu 2001-2003/Malibu Classic 2004

1. Unsnap and remove radio bezel. (Figure A)
2. Remove (3) bolts and remove radio. (Figure A)

*Continue to tab instructions*

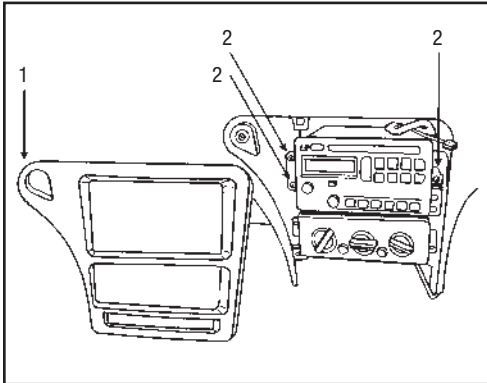

(Figure A)

### Chevrolet Metro/Suzuki Swift 1995-2001

1. Remove the ashtray and (2) Phillips screws exposed. (Figure A)
2. Remove (2) Phillips screws above the radio opening. (Figure A)
3. Unclip the radio trim bezel and disconnect the cigarette lighter wiring.
4. Remove (2) screws securing each side of the factory head unit and (1) screw from the rear support.
5. Slide the unit out and disconnect the wiring.

*Continue to tab instructions*

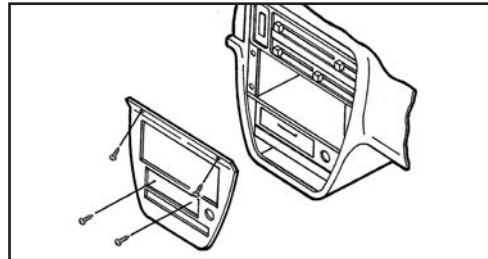

(Figure A)

### Chevrolet Monte Carlo 2000-2005

1. Unclip the trim panel above the pedals. It is NOT necessary to remove the panel it may be left hanging.
2. Remove (2) 9/32" screws from the knee panel and unclip the panel.
3. Unsnap the driver's side fuse panel cover and remove (1) 9/32" screw.
4. Open the glove box and remove (1) 9/32" screw from the upper left corner.
5. Remove (3) 9/32" screws securing the factory radio and disconnect the wiring.

*Continue to tab instructions*

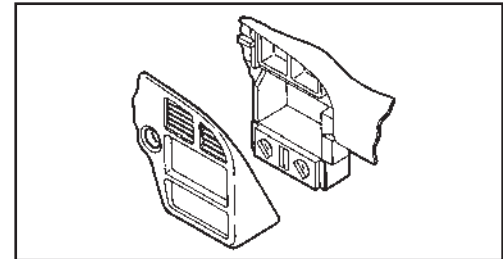



## Dash Disassembly

### Chevrolet SSR 2003-2006

1. Unclip and remove the (3) climate control knobs. (Figure A)
2. Unclip and remove the long trim panel below the radio and passenger air bag. (Figure B)
3. Unclip and remove the small trim panel to the left of the steering wheel. (Figure C)
4. Remove the (5) 9/32" screws securing the radio/instrument panel then unclip and remove the panel. (Figure D)
5. Remove the screws securing the factory head unit and disconnect the wiring.

*Continue to tab instructions*

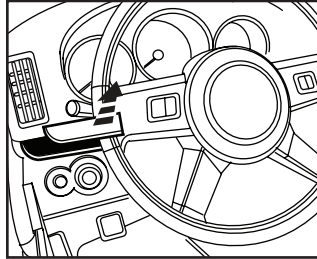

(Figure C)

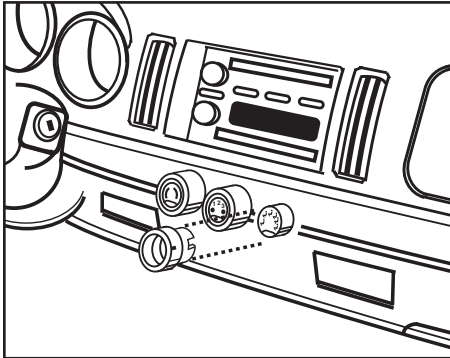

(Figure A)

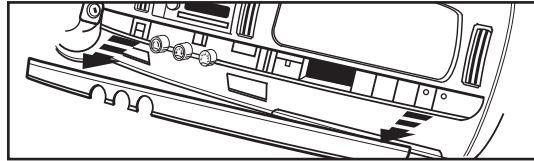

(Figure B)

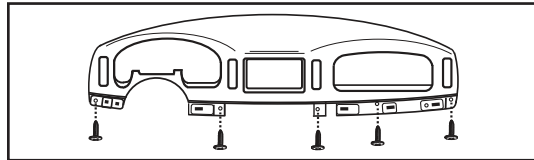

(Figure D)

### Chevrolet Tracker 1992-2004, Suzuki Sidekick 1992-1998, Vitara 1999-2005/Grand Vitara 1999-2002/XL-7 2001-2002

1. Remove the cigarette lighter and climate control knobs.
2. Remove the ashtray and the (1) exposed screw.
3. Pull out on the climate control cluster and remove the (2) exposed screws.
4. Unclip the radio trim bezel. (Figure A)
5. Remove (4) screws from the factory head unit, slide the unit out and disconnect the wiring.

*Continue to tab instructions*

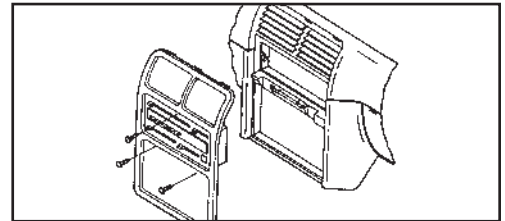

(Figure A)



## Dash Disassembly

### Chevrolet Trailblazer 2002-2009

1. Remove (2) Phillips screws inside instrument cluster.
2. Remove (1) Phillips screw under climate controls to the left of the power outlet.
3. Remove (2) 7mm hex heads from under steering column and lower the panel.
4. Remove (3) Phillips screws around steering wheel.
5. Unsnap and remove bezel (use caution when pulling over hazard switch).
6. Remove (3) 7mm hex head screws to remove radio.

*Continue to tab instructions*

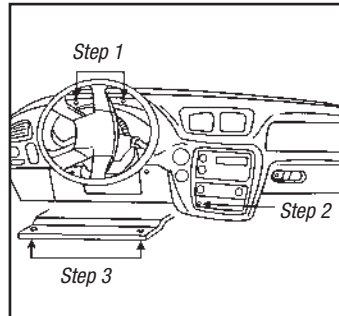
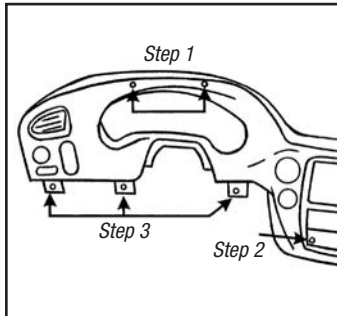

### Chevrolet Venture/ Oldsmobile Silhouette/ Pontiac Montana (except SV6) 2000

1. Remove the ashtray and (1) Phillips screw exposed in the ashtray cavity.
2. Remove (1) Phillips screw from the cigarette lighter compartment.
3. Remove (2) Phillips screws securing the factory head unit and disconnect the wiring.

*Continue to tab instructions*

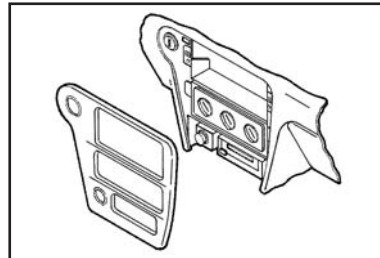

### Chevrolet Venture/ Pontiac Montana (except SV6) 2001- 2005/Oldsmobile Silhouette 2001-2004

1. Remove the ashtray and (1) Phillips screw exposed in the ashtray cavity.
2. Remove (1) Phillips screw from the cigarette lighter compartment.
3. Remove (2) Phillips screws securing the factory head unit and disconnect the wiring.

*Continue to tab instructions*

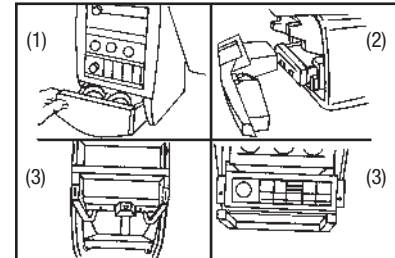



## Dash Disassembly

### GMC Envoy 2002-2009, Isuzu Ascender 2003-2009, Oldsmobile Bravada 1998-2004, Buick Rainier 2004-2007

1. Remove (4) Phillips screws, (2) from left and (2) from right of carpeted panel. (Figure A)
2. Slide carpeted panel down and backwards to reveal (2) Phillips screws and remove. (Figure B)
3. Unsnap radio bezel and unplug cigarette lighter and accessories. (Figure C)
4. Remove (3) screws and remove radio. (Figure C)

*Continue to tab instructions*

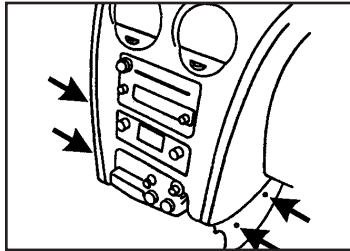

(Figure A)

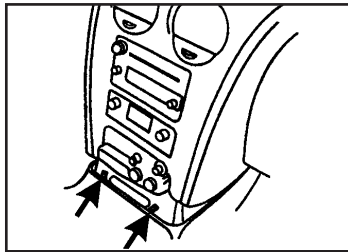

(Figure B)

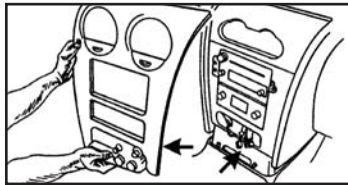

(Figure C)

### Hummer H2 2003-2007

1. Open center console and remove (4) 9/32" screws from console box and remove box. (Figure A)
2. Remove (4) Phillips screws from hinge on console door inside console and remove door. (Figure B)
3. Loosen (1) T-15 Torx on forward facing side of shift lever and pull up to remove. (Figure C)
4. Unclip cup holder/shifter trim assembly and remove. (Figure 4)

*Continue on the next page*

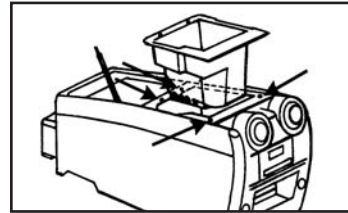

(Figure A)

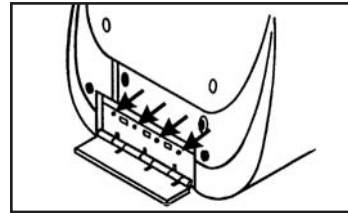

(Figure B)

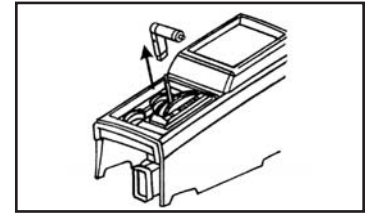

(Figure C)

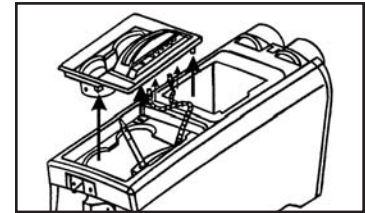

(Figure D)



## Dash Disassembly

### Hummer H2 2003-2007

5. Remove (6) Phillips screws from top of center console. (Figure E)
6. Remove (2) Phillips screws from inside pocket on back of center console, then unclip and remove. (Figure F)
7. Remove (1) 10 mm bolt to right of shift lever.
8. Remove (2) Phillips screws from under console box on driver's side and (2) Phillips screws from under console trim-top on passenger side.
9. Slide control assembly rearwards.
10. Remove (2) T-30 Torx bolts from top of radio/ climate control trim and unclip and remove. (Figure G)
11. Remove (3) 9/32" screws that hold the radio in. (Figure G)

*Continue to tab instructions*

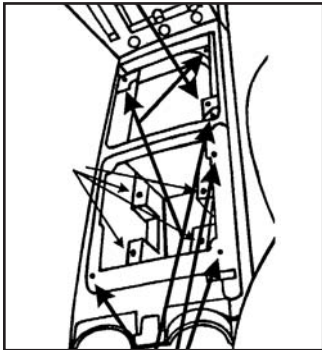

(Figure E)

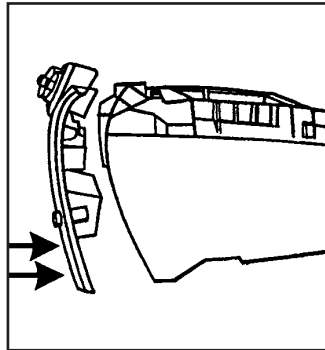

(Figure F)

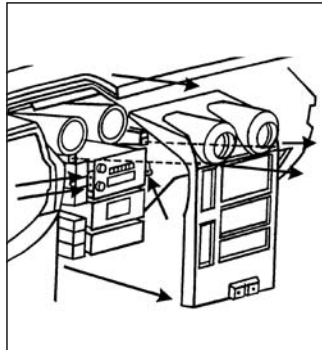

(Figure G)

### Oldsmobile Achieva 1996-1998

1. Open the glove box, press inward on the walls of the glove box liner and remove the liner.
2. Remove (10) Torx head screws from the glove box location.
3. Remove (2) 9/32" hex head screws under the steering column.
4. Unclip the dash trim bezel. (Figure A)
5. Remove the screws securing the factory head unit and disconnect the wiring.

*Continue to tab instructions*

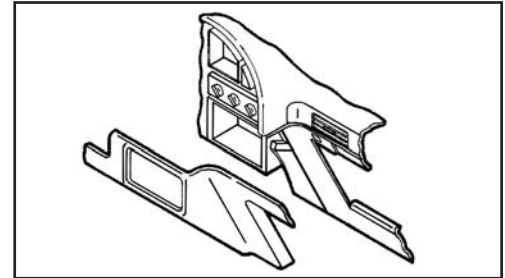

(Figure A)



## Dash Disassembly

### Oldsmobile Cutlass 1997-1999, Cutlass Supreme 1995-1997

1. Unclip the radio trim bezel and remove. (Figure A)
2. Remove (2) 9/32" hex head screws securing the factory head unit and disconnect the wiring.

*Continue to tab instructions*

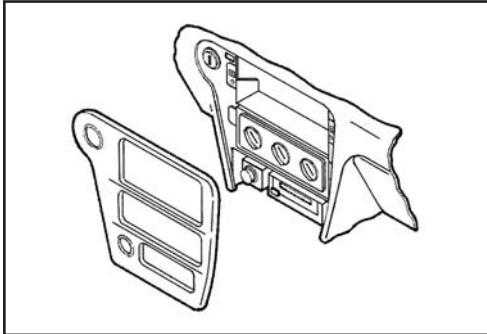

(Figure A)

### Oldsmobile Alero 1999-2004

1. Remove shift knob by using a small screwdriver to remove U-clip from front of shifter and pull upward.
2. Unclip and remove shifter trim panel.
3. Unclip and remove radio and climate control panel by pulling from bottom. (Figure A)
4. Remove (3) 9/32" screws from radio and remove.

*Continue to tab instructions*

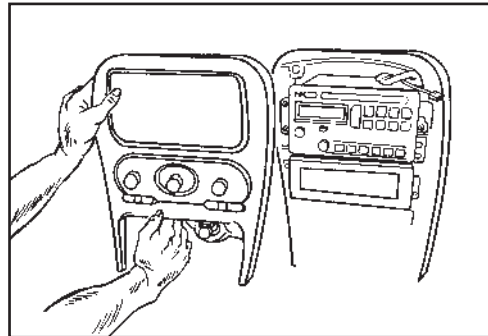

(Figure A)

### Oldsmobile Aurora 1995-2003

1. Unclip the radio trim bezel and remove the bezel. (Figure A)
2. Remove (2) 7 mm screws securing the factory head unit and disconnect the wiring.

*Continue to tab instructions*

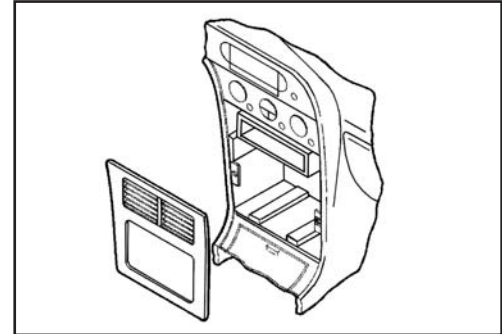

(Figure A)





## Dash Disassembly

### Oldsmobile Eighty Eight 1994-1999

1. Unclip the radio trim bezel and remove. (Figure A)
2. Remove (2) 9/32" hex head screws securing the factory head unit and disconnect the wiring.

*Continue to tab instructions*

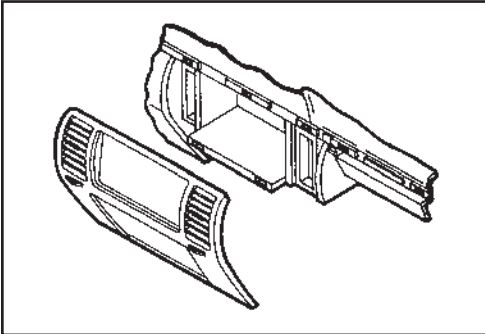

(Figure A)

### Oldsmobile Ninety Eight 1994-1996

1. Open the glove box and remove (2) hex head screws securing the wood trim.
2. Unsnap the wood trim and remove.
3. Remove (2) hex head screws below the radio trim bezel.
4. Lift up on the bezel and remove. (Figure A)
5. Remove (3) Phillips hex head screws securing the factory head unit and disconnect the wiring.

*Continue to tab instructions*

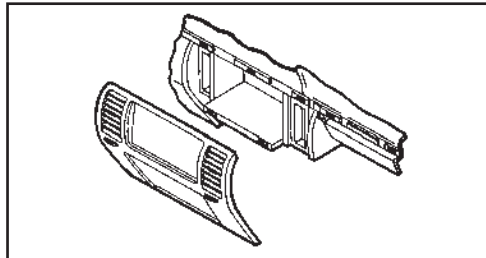

(Figure A)

### Oldsmobile Intrigue 1998-2003

1. Open the center console storage compartment and remove (2) 9/32" hex head screws exposed.
2. Remove the center console.
3. Unclip the radio trim bezel and remove. (Figure A)
4. Remove (2) 9/32" hex head screws securing the factory head unit and disconnect the wiring.

*Continue to tab instructions*

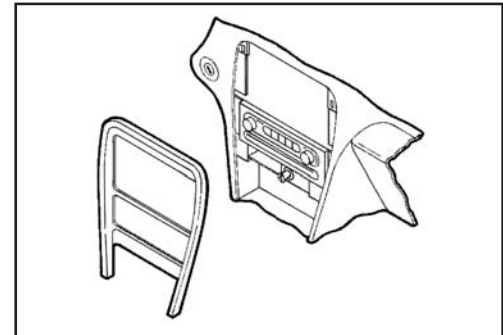

(Figure A)



## Dash Disassembly

### Honda Passport 1998-2002, Isuzu Amigo 1998-2000, Rodeo 1998-2004, Rodeo Sport 2001-2003

1. Remove the ashtray and (1) Phillips screw exposed in the ashtray cavity.
2. Unclip and remove the trim panel surrounding the factory radio. (Figure A)
3. Remove (4) Phillips screws securing the factory radio and disconnect the wiring.

*Continue to tab instructions*

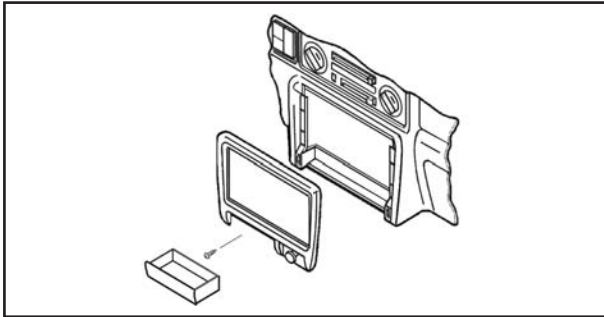

(Figure A)

### Oldsmobile L55 1996-1999 Regency 1997-1998

1. Open glove box and remove (2) center trim bezels attached by screws. (Figure A)
2. Unsnap and remove radio trim bezel. (Figure A)
3. Remove (3) 9/32" hex head screws and remove radio. (Figure B)

*Continue to tab instructions*

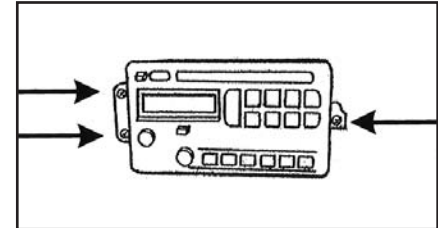

(Figure B)

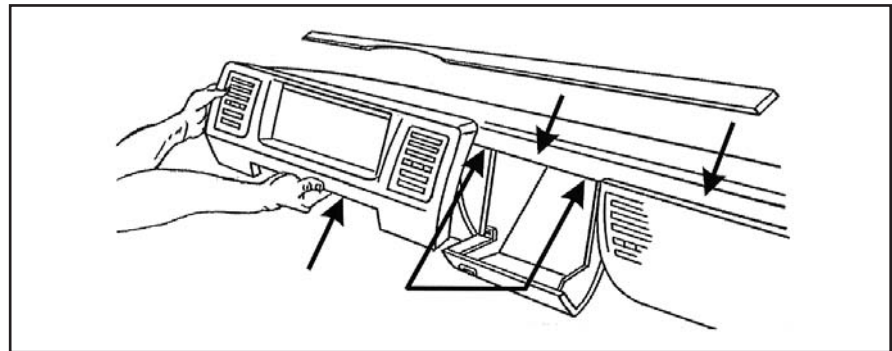

(Figure A)



## Dash Disassembly

### Pontiac Aztec 2001-2005

1. Pull out cup holder inserts.
2. Remove (1) Phillips screw exposed inside bottom cup holder.
3. Unsnap and remove shifter trim with cup holders.
4. Remove (2) #15 Torx at bottom of radio/climate bezel.

*Continue to tab instructions*

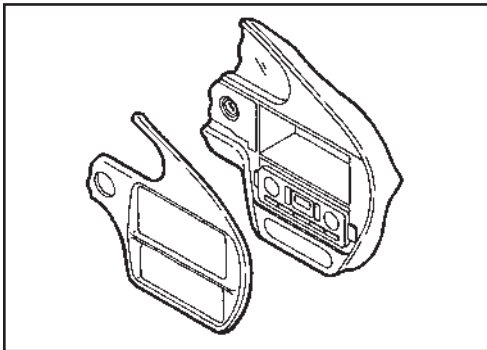

### Pontiac Bonneville 2000-2005

1. Remove (2) Phillips screws from the instrument cluster. (Figure A)
2. Unclip the ignition trim and remove. (Figure B)
3. Unclip the climate control/radio trim bezel and remove.
4. Depress the spring clips on each side of the factory head unit and remove. (Figure C)

*Continue to tab instructions*

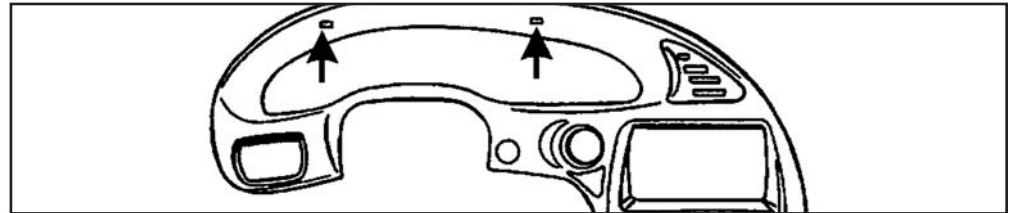

(Figure A)



(Figure B)

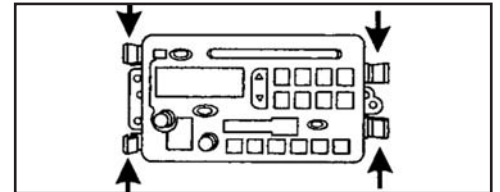

(Figure C)



## Dash Disassembly

### Pontiac Grand Am 2001-2005

1. Unsnap and remove radio trim bezel.
2. Remove (3) 9/32" screws from radio brackets and remove radio.

*Continue to tab instructions*

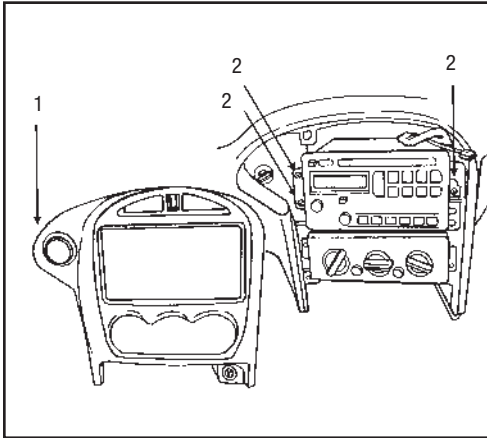

### Pontiac Sunfire 2000-2005

1. Open the glove box and remove (2) Phillips screws exposed on the right edge of the radio trim bezel.
2. Unclip the bezel and remove. (Figure A)
3. Remove (2) 7 mm hex head screws securing the factory head unit and disconnect the wiring.

*Continue to tab instructions*

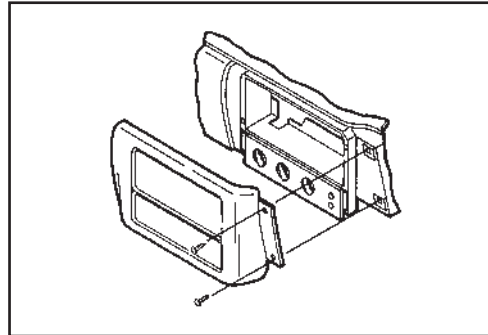

(Figure A)

### Toyota Matrix 2003-2004/Pontiac Vibe 2003-2008

1. Unclip the bottom edge of the radio trim panel then lift up and out to remove. (Figure A)

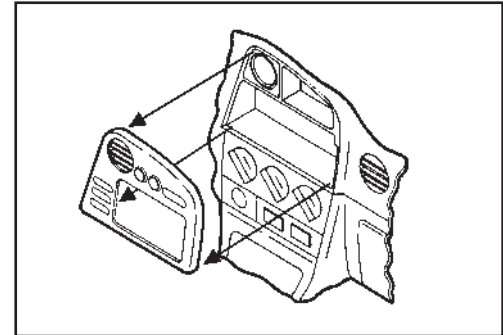

(Figure A)



## Dash Disassembly

### Toyota Matrix 2003-2004/Pontiac Vibe 2003-2008

2. Remove (4) 10 mm bolts securing the factory radio. (Figure B)

*Continue to tab instructions*

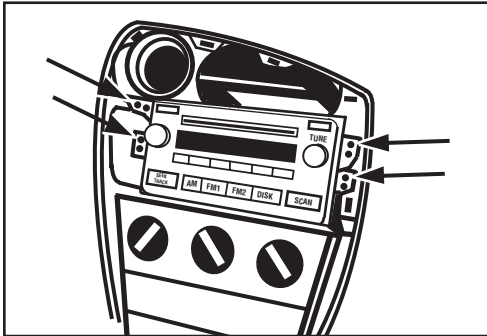

(Figure B)

### Suzuki Aerio 2002

1. Unclip the dash trim bezel and remove. (Figure A)
2. Remove (4) Phillips screws securing the factory head unit and disconnect the wiring.

*Continue to tab instructions*

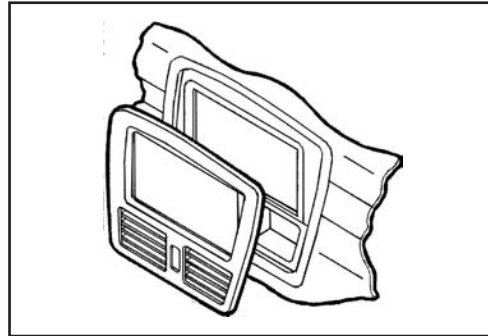

(Figure A)

### Suzuki Esteem 1995-2003

1. Remove the climate control knobs.
2. Remove (1) Phillips screw located above the radio opening. (Figure A)
3. Unclip the radio trim bezel. (Figure A)
4. Remove (4) screws from the factory head unit, slide the unit out and disconnect the wiring.

*Continue to tab instructions*

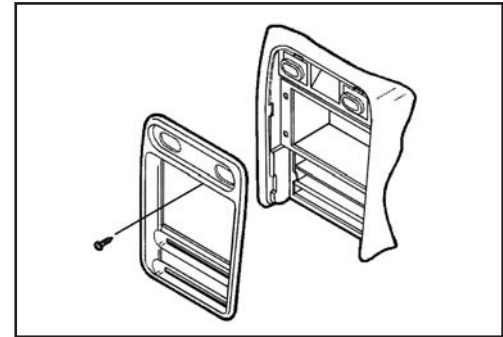

(Figure A)



## Tab Instructions 95-2009

### Tab Instructions

#### 1. GM Vehicles

Cut tabs highlighted on both sides of both brackets. (Figure A)

#### 2. Chevy Tracker/Metro/Suzuki

Cut tabs highlighted on both sides of both brackets. (Figure B)

#### 3. Cadillac Fleetwood/Brougham

Cut all tabs highlighted on both sides of both brackets. (Figure C)

#### 4. Isuzu Amigo/Rodeo/Rodeo Sport

Cut the highlighted tabs. (Figure D)

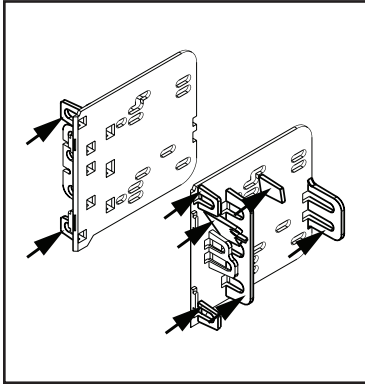

(Figure A)

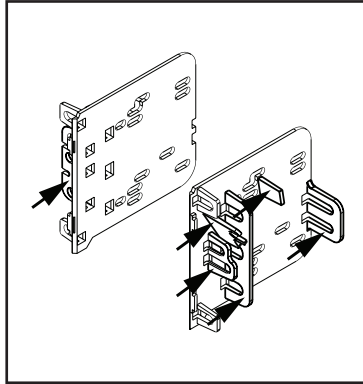

(Figure B)

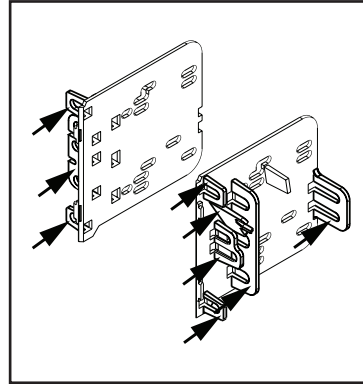

(Figure C)

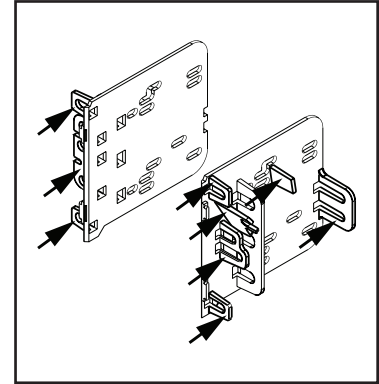

(Figure D)



## Tab Instructions 95-2009

### Tab Instructions

#### 5. Toyota Matrix/Pontiac Vibe

Cut the highlighted tabs. (Figure E)

Cut (4) tabs highlighted on DDIN trim plate. (Figure F)

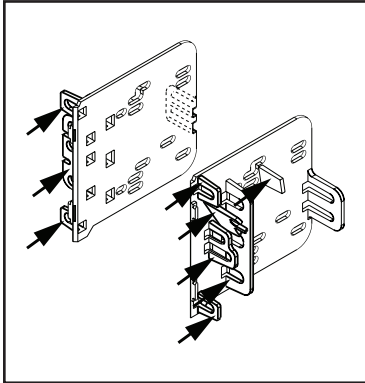

(Figure E)

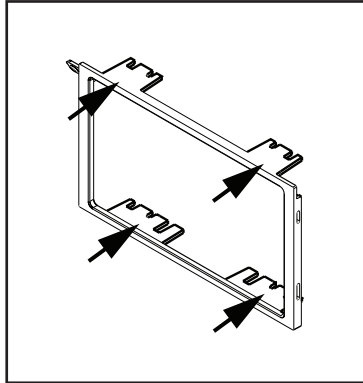

(Figure F)

#### 6. Cadillac Eldorado/Seville

Cut the highlighted tabs on the DDIN brackets. (Figure G)

Cut (1) tab highlighted on top left corner of DDIN trim plate. (Figure H)

*Continue to kit assembly*

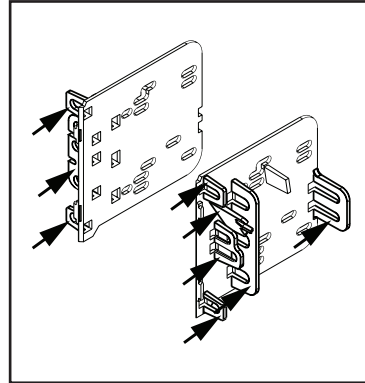

(Figure G)

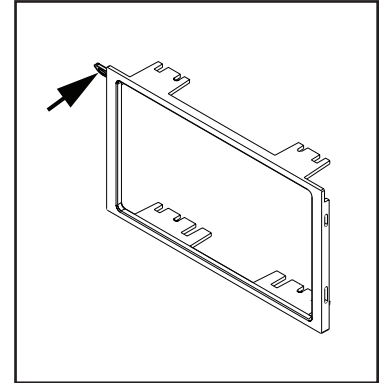

(Figure H)



## Kit Assembly 95-2009

### Cadillac Fleewood/Brougham 1990-1996

*(assembly with factory brackets)*

1. Using carriage bolts and Kep nuts supplied mount the factory brackets to the double DIN trim plate/double DIN bracket assembly (keep in mind which bracket is top and which one is bottom). (Figure A)

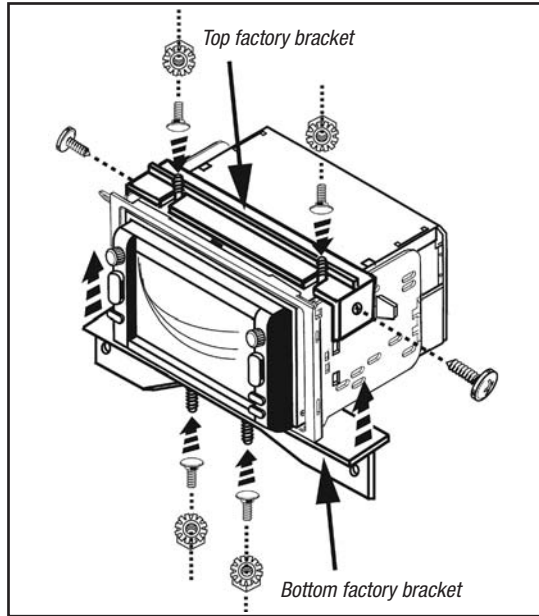

(Figure A)

### Cadillac Eldorado/Seville 1992-1995

1. Align the tabs on the bottom of the double DIN trim plate with notches in sub dash. (Figure A)
2. Secure with the (2) carriage bolts and (2) Kep nuts provided. (Figure A)

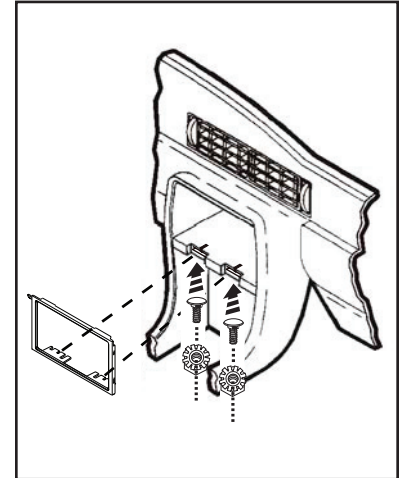

(Figure A)





## Kit Assembly 95-2009

### Double DIN radio/Stacked ISO mount unit provision

1. Snap the Double DIN brackets to the edge of the Double DIN trim plate. (Figure A)
2. Slide the Double DIN head unit or stacked ISO head units into the bracket/radio housing assembly and secure the Double DIN head unit or stacked ISO head units to the assembly using the screws supplied with the radio. (Figure B)
3. Locate the factory wiring harness in the dash. Metra recommends using the proper mating adapter from Metra or AXXESS. Re-connect the negative battery terminal and test the unit for proper operation.
4. Reassemble dash in reverse order of disassembly.

**Note:** For the Buick LeSabre, Oldsmobile Aurora, and the Pontiac Bonneville the (3) speed clips and screws provided with the kit will need to be installed into the sub dash where the screw holes line up on the kit.

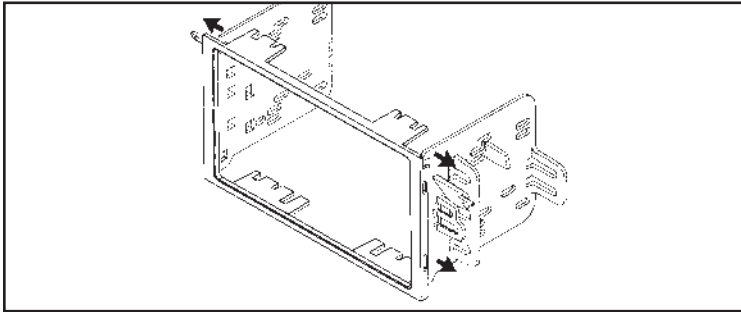

(Figure A)

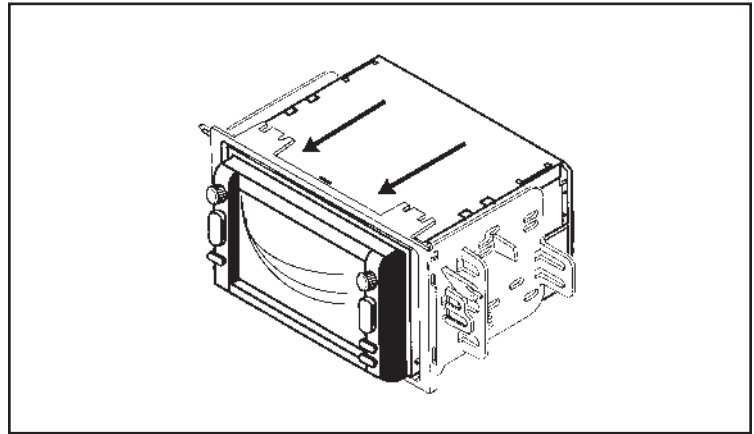

(Figure B)



## Tab Instructions 99-2009

### Tab Instructions

#### 1. GM Vehicles

Cut tabs highlighted on both sides of radio housing. (Figure A)

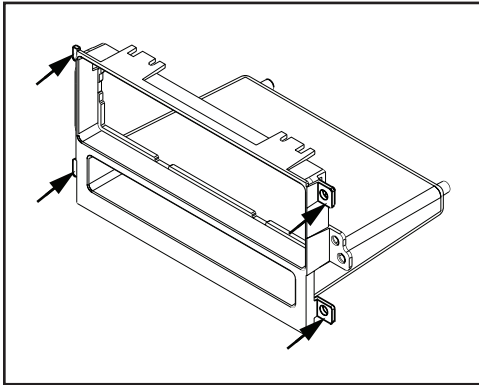

(Figure A)

#### 2. Chevy Tracker/Metro/Suzuki

Cut tabs highlighted on both sides of radio housing. (Figure B)

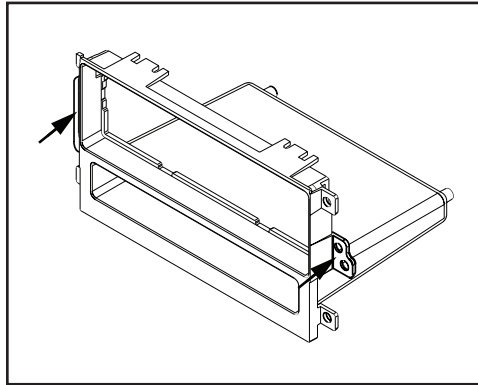

(Figure B)

#### 3. Cadillac Fleetwood/Brougham

Cut all tabs highlighted on both sides of radio housing. (Figure C)

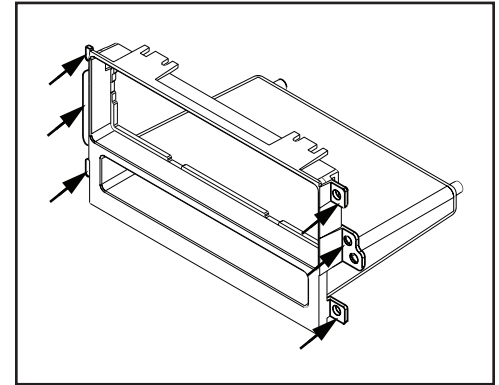

(Figure C)



## Tab Instructions 99-2009

### Tab Instructions

#### 4. Isuzu Amigo/Rodeo/Rodeo Sport

Cut tabs highlighted on both sides of both brackets. (Figure D)

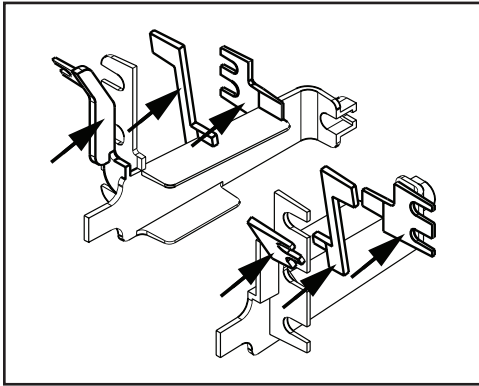

(Figure D)

#### 5. Toyota Matrix/Pontiac Vibe

Cut tabs highlighted on both sides of both brackets.

Cut (4) tabs highlighted on double DIN trim plate. (Figure E)

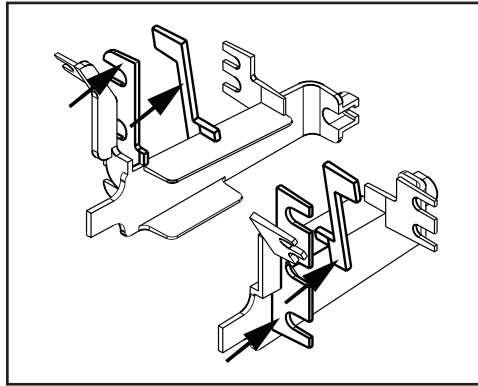

(Figure E)

#### 6. Cadillac Eldorado/Seville

Cut tabs highlighted on both sides of both brackets. (Figure F)

*Continue to kit assembly*

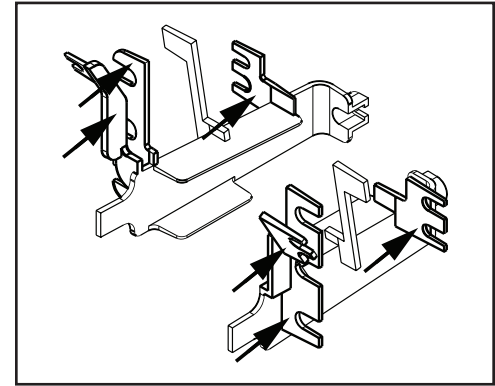

(Figure F)



## Kit Assembly 99-2009

### Cadillac Fleewood/Brougham 1990-1996

*(assembly with factory brackets)*

1. After mounting (2) side radio housing brackets supplied to the radio housing, using (2) #8 3/8" Phillips screws supplied, mount the bottom factory bracket to the radio housing/bracket assembly using (2) carriage bolts and (2) Kep nuts supplied. (Figure A)

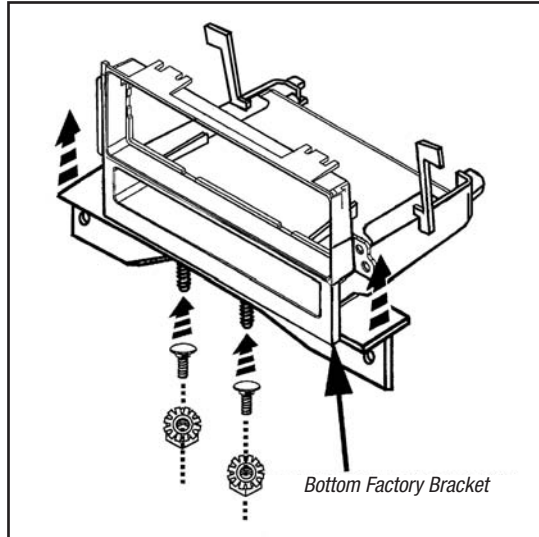

(Figure A)

### Cadillac Eldorado/Seville 1992-1995 *(assembly with factory brackets)*

1. Align the tabs on the bottom of the bottom factory bracket with the notches in sub dash.
2. Secure with the (2) Carriage bolts and (2) Kep nuts provided. (Figure A)

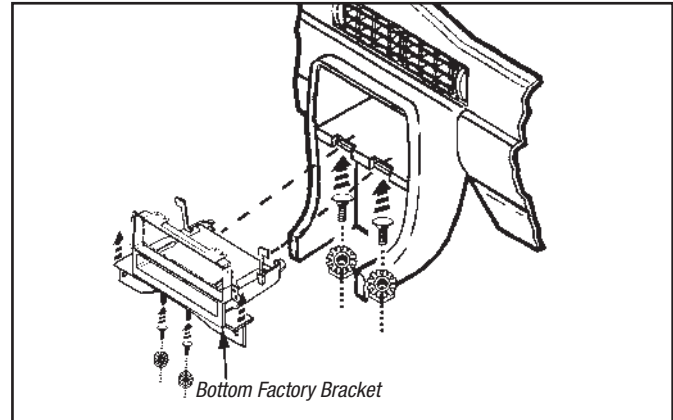

(Figure A)



## Kit Assembly 99-2009

### ISO mount radio provision with pocket

1. Cut radio housing support bars and remove. (Figure A)
2. Slide the radio housing brackets onto the pocket and secure with the supplied (2) #8 3/8" screws. (Figure B)
3. Mount the ISO Brackets to the head unit with the screws supplied with the unit. (Figure C)
4. Slide the head unit into the radio opening until the side clips engage. (Figure D)

5. Snap the trim plate into the single DIN radio housing. (Figure D)

**Note:** For the Buick LeSabre, Oldsmobile Aurora and the Pontiac Bonneville the (3) speed clips and screws provided with the kit will need to be installed into the sub dash where the screw holes line up on the kit.

6. Locate the factory wiring harness in the dash. Metra recommends using the proper mating

adapter from Metra or AXCESS. Re-connect the negative battery terminal and test the unit for proper operation.

7. Reassemble dash in reverse order of disassembly.

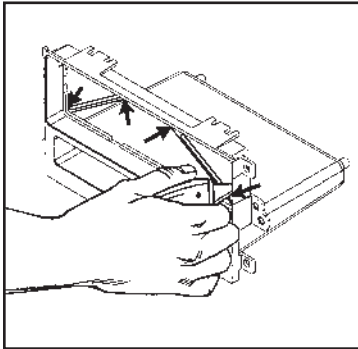

(Figure A)

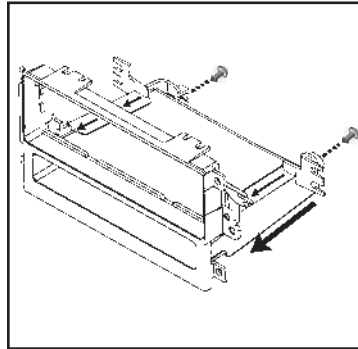

(Figure B)

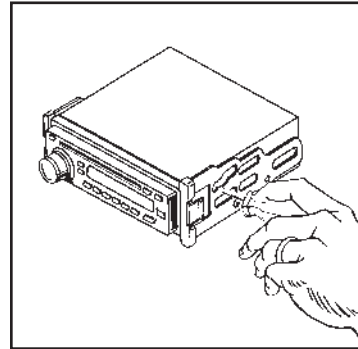

(Figure C)

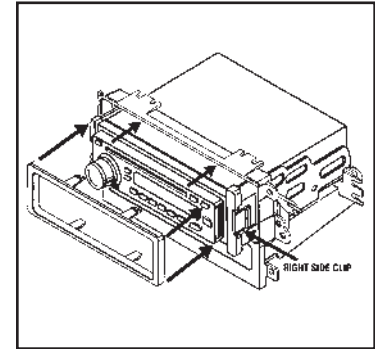

(Figure D)



## Kit Assembly 99-2009

### Double DIN radio provision with pocket

1. Cut radio housing support bars and remove.  
(Figure A)

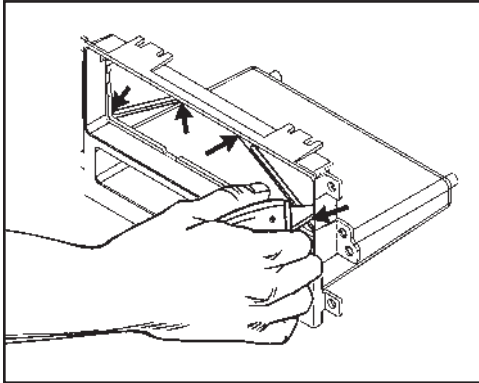

(Figure A)

2. Slide the radio housing brackets onto the pocket and secure with the supplied (2) #8 3/8" screws.  
(Figure B)

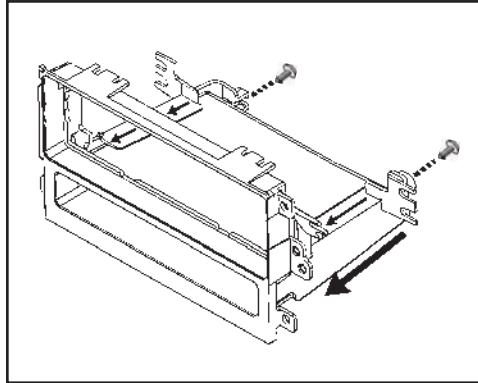

(Figure B)

3. Slide the DIN cage into the radio housing and secure by bending the metal locking tabs down.  
(Figure C)

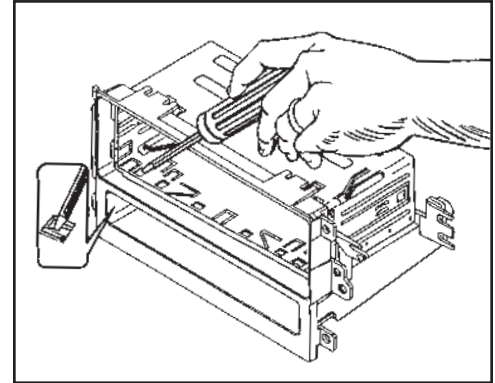

(Figure C)



## Double DIN radio provision with pocket

- Slide the aftermarket head unit into the cage and secure. (Figure D)

**Note: (1)** For the Buick LeSabre, Oldsmobile Aurora and the Pontiac Bonneville the (3) speed clips and screws provided with the kit will need to be installed into the sub dash where the screw holes line up on the kit.

**(2)** A snap-in DIN spacer has been provided for some applications where depth is an issue. Snap the spacer in the housing and slide DIN cage into the assembly and secure by bending metal locking tabs down. (Figure E)

- Locate the factory wiring harness in the dash. Metra recommends using the proper mating adapter from Metra or AXXESS. Re-connect the negative battery terminal and test the unit for proper operation.
- Reassemble dash in reverse order of disassembly.

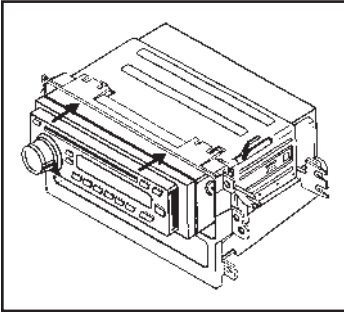

(Figure D)

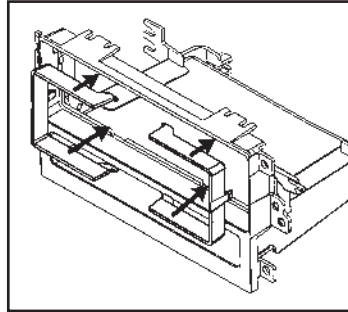

(Figure E)

## Notes

---

---

---

---

---

---

---

---

---

---

---

---

---

---

---

---

---

---

---

---

---

---

---

---

---

---



## INSTALLATION INSTRUCTIONS FOR PART 95-2009 or 99-2009



REV. 9/19/2013 INST-2009



### KNOWLEDGE IS POWER

Enhance your installation and fabrication skills by enrolling in the most recognized and respected mobile electronics school in our industry. Log onto [www.installerinstitute.com](http://www.installerinstitute.com) or call 800-354-6782 for more information and take steps toward a better tomorrow.

**Metra recommends MECP  
certified technicians**

**METRA. The World's best kits.™**

**1-800-221-0932**

**[metraonline.com](http://metraonline.com)**

© COPYRIGHT 2004-2011 METRA ELECTRONICS CORPORATION





## INSTRUCCIONES DE INSTALACIÓN PARA LA PIEZA 95-2009 o 99-2009

### APLICACIONES

Lista de aplicaciones dentro

# GM/Suzuki multi-kit 1999-2011 95-2009 o 99-2009

### CARACTERÍSTICAS DEL KIT

95-2009:

- Provisión de radio doble DIN
- Provisión de unidad de montaje ISO vertical

99-2009:

- Provisión de radio DIN con bolsillo
- Provisión de radio ISO DIN con bolsillo



### COMPONENTES DEL KIT

95-2009: • A1 Soportes doble DIN • B1 Placa de moldura doble DIN • C1 Espaciadores • D1 (4) Pernos cabeza de hongo • E1 (4) Tuercas keps • F1 (3) Tornillos y (3) ganchos de velocidad

99-2009: • A2 Carcasa del radio • B2 Soportes de la carcasa del radio • C2 Placa de moldura • D2 Soportes ISO • E Espaciador DIN • F2 (4) pernos cabeza de hongo • G2 (4) tuercas keps • H2 (3) tornillos y (3) ganchos de velocidad • I2 (2) #8 tornillos Phillips de 3/8"

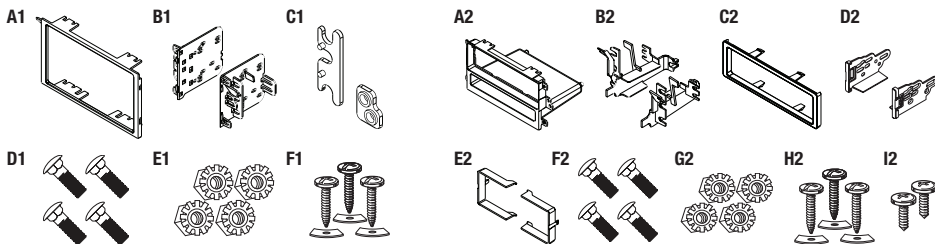

### CABLEADO Y CONEXIONES DE ANTENA

Arnés de cableado: (se venden por separado)

- Visite [www.metraonline.com](http://www.metraonline.com) para ver las aplicaciones específicas de la interfase

Adaptador de antena:

- 40-GM10 - Adaptador de antena GM 1988 y más recientes
- 40-CR10 - Adaptador de antena Chrysler 2002 y más recientes

### HERRAMIENTAS REQUERIDAS

- Herramientas de corte • Destornillador Phillips
- Llave de tubo

**PRECAUCIÓN:** Metra recomienda desconectar el terminal negativo de la batería antes de comenzar cualquier instalación. Todos los accesorios, interruptores y, especialmente, las luces indicadoras de airbag deben estar enchufados antes de volver a conectar la batería o comenzar el ciclo de ignición.

**NOTA:** Remítase a las instrucciones incluidas con el radio de postventa.

REV.9/19/2013 INST-2009



INST-2009

## Aplicaciones

### Buick

Century.....	1997-2005
LeSabre.....	1995-2005
Park Avenue.....	1995-2005
Rainier.....	2004-2007
Regal.....	1995-2004
Rendezvous.....	2002-2007
Riviera.....	1996-1999
Roadmaster.....	1995-1996
Skylark.....	1996-1998

### Cadillac

Escalade ESV/EXT.....	2003-2006
Brougham.....	1990-1996
Eldorado.....	1992-1995
Fleetwood.....	1990-1996
Seville.....	1992-1995

### Chevrolet

Avalanche.....	2003-2006
Blazer (con DDIN).....	2002-2005
Cavalier.....	2000-2005

### Chevrolet (seguido)

Colorado.....	2004-2012
Express Van (completo)....	2001-2007
Impala.....	2000-2005
Kodiak.....	2003-2009
Malibu.....	2001-2003
Malibu Classic.....	2004
Metro/Geo.....	1995-2001
Monte Carlo.....	2000-2005
SSR.....	2003-2006
S-10 Pickup (con DDIN) ...	2002-2004
Silverado.....	2003-2006
Silverado Classic.....	2007
Suburban.....	2003-2006
Tahoe.....	2003-2006
Tracker.....	1992-2004
Trailblazer.....	2002-2009
Venture.....	2000-2005

### GMC

Canyon.....	2004-2012
-------------	-----------

### GMC (seguido)

Envoy.....	2002-2009
Savana.....	2001-2007
Sierra.....	2003-2006
Sierra Classic.....	2007
Sonoma (con DDIN).....	2002-2004
Top Kick.....	2005-2009
Yukon/Denali/XL.....	2003-2006

### Honda

Passport.....	1998-2002
---------------	-----------

### Hummer

H2.....	2003-2007
---------	-----------

### Isuzu

Ascender.....	2003-2009
Amigo.....	1998-2000
i290/i370.....	2007-2008
i280/i350.....	2006
Rodeo.....	1998-2004
Rodeo Sport.....	2001-2003

### Oldsmobile

Achieva.....	1996-1998
Alero.....	1999-2004
Aurora.....	1995-2003
Bravada.....	1998-2001
Bravada.....	2002-2004
Cutlass.....	1997-1999
Cutlass Supreme.....	1995-1997
Eighty-Eight.....	1994-1999
Intrigue.....	1998-2003
LSS.....	1996-1999
Ninety-Eight.....	1994-1996
Regency.....	1997-1998
Silhouette.....	2000-2004

### Pontiac

Aztec.....	2001-2005
Bonneville.....	2000-2005
Grand Am.....	2001-2005
Montana.....	2000-2005
Sunfire.....	2000-2005

### Suzuki

Aerio.....	2002
Esteem.....	1995-2003
Sidekick.....	1992-1998
Swift.....	1995-2001
Vitara.....	1999-2005
Grand Vitara.....	1999-2002
XL-7.....	2001-2002

### Toyota

Matrix.....	2003-2004
-------------	-----------



INST-2009

## Índice

### Dash Disassembly

- Buick Century 1997-2005/ Regal 1995-2004.....	4
- Buick LeSabre/Park Avenue 1995-1999.....	4
- Buick LeSabre/Park Avenue 2000-2005.....	4
- Buick Rendezvous 2002-2007.....	5
- Buick Riviera 1996-1999.....	5
- Buick Roadmaster 1995-1996.....	10
- Buick Skylark 1996-1998.....	6
- Cadillac Eldorado/Seville 1992-1995.....	7
- Cadillac Escalade ESV/EXT/Chevrolet Avalanche/Suburban/Tahoe 2003-2006.....	6
- Cadillac Fleetwood/ Brougham 1990-1996.....	6-7
- Chevrolet Blazer 2002-2005.....	8
- Chevrolet Cavalier 2000-2005.....	8
- Chevrolet Colorado 2004-2012/ GMC Canyon 2004-2012.....	9
- Chevrolet Express Van/ GMC Savana 2001-2002.....	9
- Chevrolet Express Van/ GMC Savana 2003-2007.....	10
- Chevrolet Impala 2000-2005.....	10
- Chevrolet Malibu 2001-2003/ Malibu Classic 2004.....	11

- Chevrolet Metro/ Suzuki Swift 1995-2001.....	11
- Chevrolet Monte Carlo 2000-2005.....	11
- Chevrolet S-10 (con DDIN/ GMC Sonoma (con DDIN) 2002-2004.....	8
- Chevrolet Silverado/GMC Sierra 2003-2006, Chevrolet Silverado Classic/GMC Sierra Classic 2007, Chevrolet Kodiak 2003-2009.....	6
- Chevrolet SSR 2003-2006.....	12
- Chevrolet Tracker 1992-2004/Suzuki Sidekick 1992-1998/Vitara 1999-2005...	12
- Chevrolet Trailblazer 2002-2009.....	13
- Chevrolet Venture/Oldsmobile Silhouette/ Pontiac Montana (excepto SV6) 2000.....	13
- Chevrolet Venture/Pontiac Montana (excepto SV6) 2001-2005.....	13
- GMC Envoy 2002-2009/ Isuzu Ascender 2003-2009.....	14
- GMC Top Kick, Yukon/Denali/XL 2003-2006.....	6
- Honda Passport 1998-2002.....	18
- Hummer H2 2003-2007.....	14-15
- Isuzu i290/i370 2007-2008.....	9
- Isuzu i280/i350 2006.....	9

- Isuzu Amigo 1998-2000/Rodeo 1998-2004/Rodeo Sport 2001-2003.....	18
- Oldsmobile Achieva 1996-1998.....	15
- Oldsmobile Alero 1999-2004.....	16
- Oldsmobile Aurora 1995-2003.....	16
- Oldsmobile Bravada 1998-2004/ Buick Rainier 2004-2007.....	14
- Oldsmobile Bravada 1998-2001.....	8
- Oldsmobile Cutlass 1997-1999/ Cutlass Supreme 1995-1997.....	16
- Oldsmobile Eighty Eight 1994-1999.....	17
- Oldsmobile Ninety Eight 1994-1996.....	17
- Oldsmobile Intrigue 1998-2003.....	17
- Oldsmobile LSS 1996-1999/ Regency 1997-1998.....	18
- Oldsmobile Silhouette 2001-2004.....	13
- Pontiac Aztec 2001-2005.....	19
- Pontiac Bonneville 2000-2005.....	19
- Pontiac Grand Am 2001-2005.....	20
- Pontiac Sunfire 2000-2005.....	20
- Suzuki Aerio 2002.....	21
- Suzuki Esteem 1995-2003.....	21
- Suzuki Grand Vitara 1999-2002/ XL-7 2001-2002.....	12

- Toyota Matrix 2003-2004/ Pontiac Vibe 2003-2008.....	21
---	----

### Tab Instruction

#### 95-2009:

- Cadillac/Chevy/GMC/Isuzu/Metro/ Pontiac/Suzuki/Toyota.....	22-23
---	-------

#### 95-2009:

- Cadillac/Chevy/GMC/Isuzu/Metro/ Pontiac/Suzuki/Toyota.....	26-27
---	-------

### Kit Assembly

#### 95-2009:

- Cadillac Fleetwood/Brougham 1990-1996 (con soportes de montaje).....	24
- Cadillac Eldorado/Seville 1992-1995.....	24
- Double DIN radio/Stacked ISO mount unit provision.....	25

#### 99-2009:

- Cadillac Fleetwood/Brougham 1990-1996 (con soportes de montaje).....	28
- Cadillac Eldorado/Seville 1992-1995.....	28
- ISO mount radio provision con pocket.....	29
- DDIN radio provision con pocket.....	30-31



## Desmontaje del tablero

### Buick Century 1997-2005 Regal 1995-2004

1. Retire la pieza de moldura de plástico a la izquierda de la guantera y (1) tornillo Phillips expuesto.
2. Suelte a presión el borde superior del panel del protector de rodillas.
3. Retire (1) tornillo Phillips del panel.
4. Retire el conjunto del cenicero y los (2) tornillos Phillips de cada lado.
5. Desenganche todo el bisel de la moldura del tablero y retire. (Figura A)
6. Abra las puertas y suelte las tapas de los extremos de cada lado del tablero.
7. Suelte y retire el panel del radio/conjunto de instrumentos.
8. Retire los (3) tornillos para retirar el radio.

*Continúe con las instrucciones para pestañas*

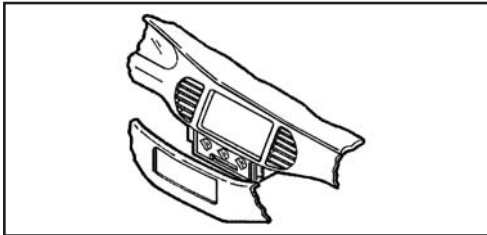

(Figura A)

### Buick LeSabre/Park Avenue 1995-1999

1. Suelte a presión el panel de la moldura del control de clima (de puerta a puerta) y retire los (4) tornillos Phillips expuestos.
2. Saque a presión las rejillas del aire acondicionado y retire (1) tornillo Phillips expuesto en cada cavidad de la rejilla.
3. Desenganche el bisel de la moldura del radio y retire.
4. Retire los tornillos que sujetan la unidad central de fábrica y desconecte el cableado.

*Continúe con las instrucciones para pestañas*

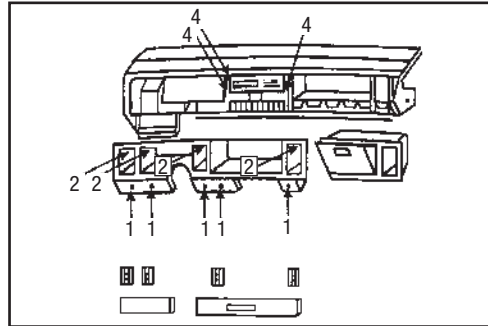

### Buick LeSabre/Park Avenue 2000-2005

1. Abra la puerta del conductor y suelte a presión y retire la tapa del extremo del tablero.
2. Suelte a presión y retire la moldura a lo largo del centro del tablero (una pieza a la derecha y una a la izquierda del volante).
3. Suelte y retire el bisel del radio/instrumentos. (Figura A)
4. Retire los (2) tornillos para retirar el radio.

*Continúe con las instrucciones para pestañas*

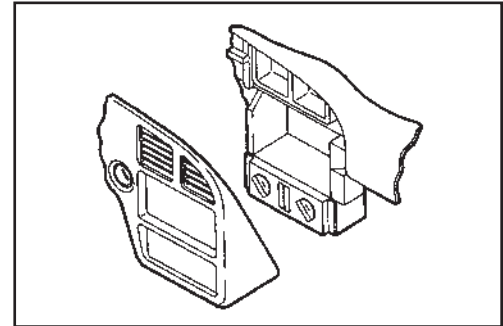

(Figura A)



## Desmontaje del tablero

### Buick Rendezvous 2002-2007

1. Abra la consola central y retire (2) tornillos al frente de la apertura de la consola. (Figura A)
2. Retire los revestimientos de los portavasos y de la cavidad de almacenamiento junto a los portavasos, luego retire los tornillos. Suelte y retire el panel. (Figura B)
3. Retire (2) tornillos de la parte inferior del bisel del radio/control de clima, desenganche y retire. (Figura C)
4. Retire (3) tornillos cabeza hexagonal de 9/32" para retirar el radio. (Figura D)  
*Continúe con las instrucciones para pestañas*

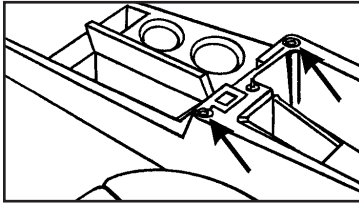

(Figura A)

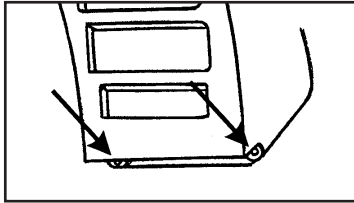

(Figura C)

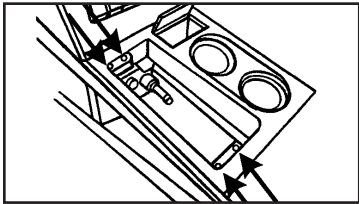

(Figura B)

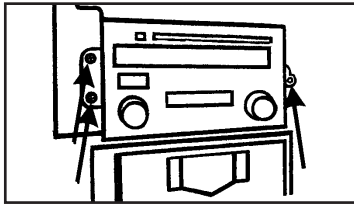

(Figura D)

### Buick Riviera 1996-1999

1. Suelte a presión el panel del lado izquierdo, exponiendo (1) tornillo Phillips debajo del panel y retire. (Figura A)
2. Suelte a presión el panel del lado derecho para exponer (1) tornillo Phillips debajo del panel y retire. (Figura A)
3. Suelte a presión la parte inferior del tablero que sobresale para soltar los (6) remaches de plástico y retire el panel. (Figura A)
4. Retire los (5) tornillos de cabeza hexagonal expuestos debajo de la parte que sobresale. (Figura B)
5. Suelte a presión el borde inferior del bisel de la moldura y luego, mientras sostiene la parte que sobresale, suelte y retire el bisel de la moldura, retirando cualquier arnés necesario.
6. Retire los (3) tornillos Phillips para retirar el control de clima.
7. Retire los (2) tornillos Phillips para retirar el soporte posterior y (3) tornillos de cabeza hexagonal de 9/32" para retirar el radio.

*Continúe con las instrucciones para pestañas*

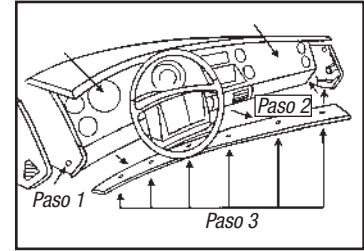

(Figura A)

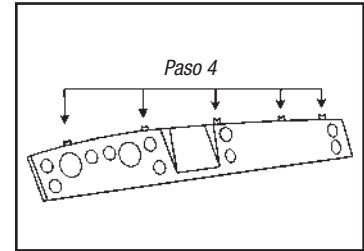

(Figura B)



## Desmontaje del tablero

### Buick Skylark 1996-1998

1. Retire los (6) tornillos de 9/32" del interior de la guantera.
2. Debajo de la guantera y del protector de rodillas del conductor, retire (2) paneles de plástico girando los (2) sujetadores 1/4 de vuelta por lado.
3. Retire los (4) tornillos de 9/32" que se revelan (2 por lado).
4. Suelte a presión el panel desde el lado del conductor hasta el

lado del pasajero.

5. Retire los (3) tornillos de 9/32" para retirar el radio.

*Continúe con las instrucciones para pestañas*

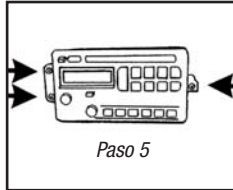

Paso 5

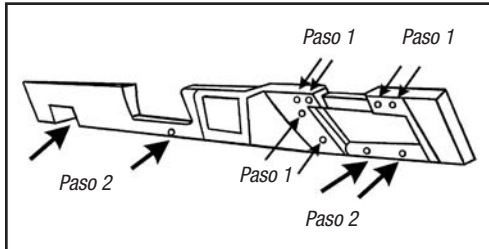

### Cadillac Escalade ESV/EXT/ Chevrolet Avalanche/Suburban/ Tahoe 2003-2006, Chevrolet Kodiak 2003-2009, Chevrolet Silverado/GMC Sierra 2003-2006, Chevrolet Silverado Classic/GMC Sierra Classic 2007, GMC Top Kick 2005-2009, GMC Yukon/ Denali/XL 2003-2006

1. Suelte y retire el bisel del tablero. (Figura A)
2. Retire los (3) tornillos de 9/32" y retire el radio.

*Continúe con las instrucciones para pestañas*

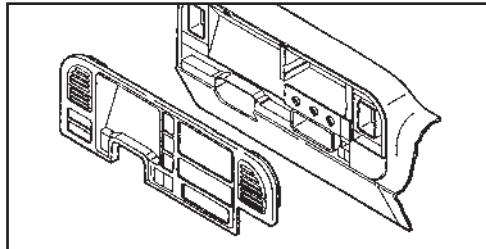

(Figura A)

### Cadillac Fleetwood/ Brougham 1990-1996

1. Suelte a presión cuidadosamente el panel de la moldura arriba de los control del aire acondicionado. (Figura A)
2. Retire los (2) tornillos de 7mm en la parte superior del bisel del radio/aire acondicionado, luego desenganche el panel y retire. (Figura B & C)
3. Retire los (4) tornillos de 7mm que sostienen el radio, deslícelo hacia fuera, desconecte los arneses del radio y retire el radio. (Figura D)

*Siga Radio Soporte Desmontaje (pág. 7)*

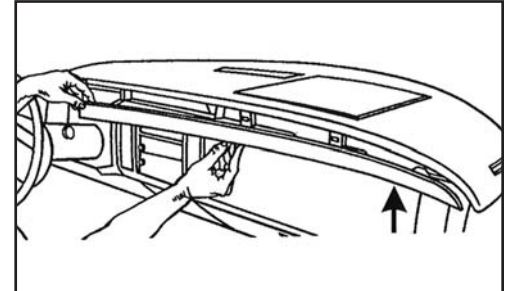

(Figura A)



## Desmontaje del tablero

### Cadillac Fleetwood/ Brougham 1990-1996

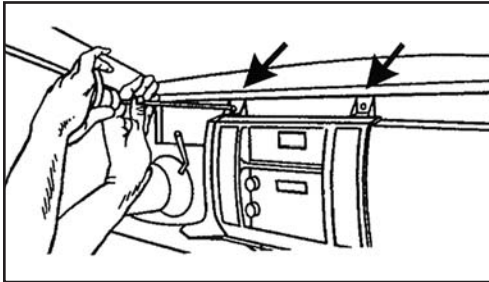

(Figura B)

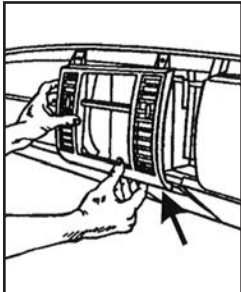

(Figura C)

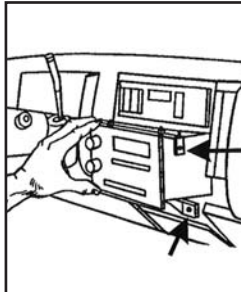

(Figura D)

### Cadillac Fleetwood/ Brougham 1990-1996 Radio Bracket Disassembly

1. Retire las (4) tuercas de 10mm, (2) arriba del radio y (2) abajo del radio que sostienen los soportes de montaje.
2. Reserve los soportes y las tuercas para el ensamble del kit.

*Continúe con las instrucciones para pestañas*

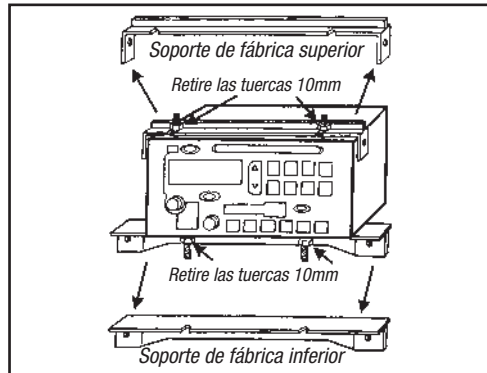

### Cadillac Eldorado/Seville 1992-1995

1. Usando una herramienta de remoción de panel, haga palanca para sacar el aro de la moldura del radio y retire.

**Precaución:** *Tenga mucho cuidado al retirar.*

2. Haga palanca gentilmente sobre el bisel de la moldura del cenicero/la palanca de velocidades y retire. (Figura A)

**Nota:** *Algunos modelos están equipados con bisel de madera real.*

3. Retire las (2) tuercas que sujetan la parte inferior de la unidad central de fábrica y desconecte el cableado.

*Continúe con las instrucciones para pestañas*

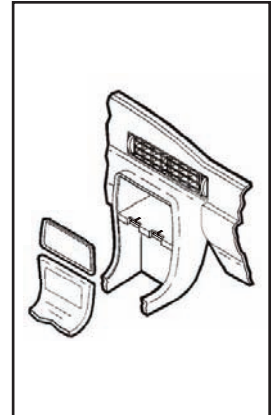

(Figura A)



## Desmontaje del tablero

### **Chevrolet Blazer** (con DDIN) **2002-2005, Chevrolet 5-10** (con DDIN)/**GMC Sonoma** (con DDIN) **2002-2004, Oldsmobile Bravada** 1998-2001

1. Retire los (2) tornillos de cabeza hexagonal de 9/32" del panel del protector de rodillas.
  2. Jale hacia abajo el panel y retire los tornillos de cabeza hexagonal de 9/32" expuestos en la parte inferior del bisel de la moldura del tablero.
  3. Retire (1) tornillo Phillips de arriba del conjunto de instrumentos.
  4. Desenganche el bisel de la moldura del tablero y retire.
  5. Retire los (2) tornillos de cabeza hexagonal de 9/32" que sujetan la unidad central de fábrica y desconecte el cableado.
- Continúe con las instrucciones para pestañas*

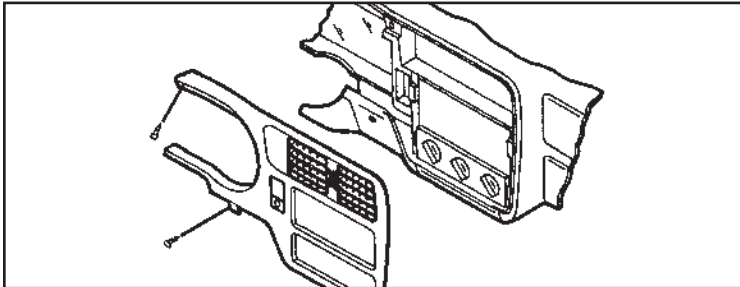

(Figura A)

### **Chevrolet Cavalier** **2000-2005**

1. Abra la puerta del conductor y retire el panel de fusibles en el extremo del tablero.
  2. Abra la puerta del pasajero y retire el panel del extremo del tablero.
  3. Retire (1) tornillo Phillips expuesto de cada lado.
  4. Retire los (3) tornillos de la parte superior del revestimiento de la guantera.
  5. Retire los (2) tornillos de la esquina superior izquierda de la
  6. Retire (1) tornillo Phillips del conducto del desempañador.
  7. Retire el ducto y (1) tornillo Phillips expuesto.
  8. Retire la almohadilla del tablero y (3) tornillos Phillips expuestos en la parte superior del bisel de la moldura del radio.
- Continúe con las instrucciones para pestañas*

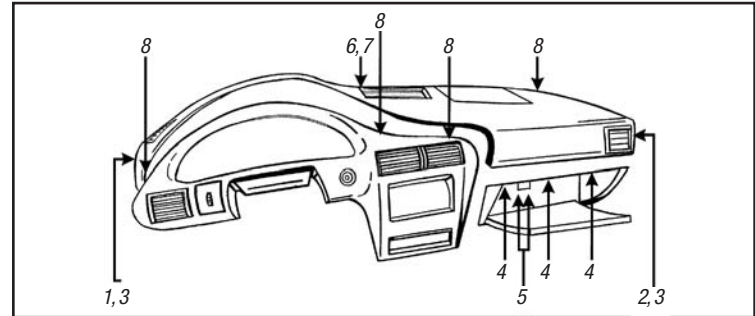





## Desmontaje del tablero

### Chevrolet Colorado 2004-2012, GMC Canyon 2004-2012, Isuzu i290/i370 2007-2008, Isuzu i280/i350 2006

1. Suelte y retire todo el panel que rodea el radio y los controles del aire acondicionado. (Figura A)
2. Retire los (3) tornillos de 9/32" que sujetan el radio para retirarlo. (Figura B)

*Continúe con las instrucciones para pestañas*

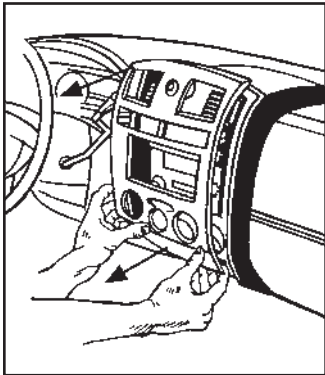

(Figura A)

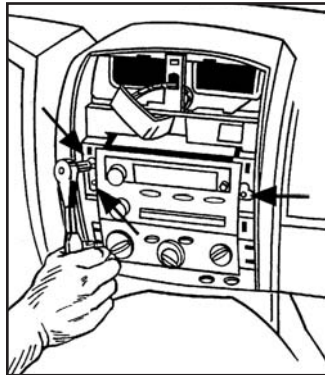

(Figura B)

### Chevrolet Express Van/GMC Savana 2001-2002

1. Suelte a presión y retire el pequeño panel de la moldura debajo de la columna de dirección. (Figura A)
2. Suelte a presión el panel del radio/clima/instrumentos. (Figura B)
3. Mueva la palanca de velocidades a la posición del primer cambio.
4. Gire el panel hacia la izquierda para levantarlo sobre la columna de dirección y retire.
5. Retire (3) tornillos cabeza hexagonal de 9/32" para retirar el radio. (Figura C)

*Continúe con las instrucciones para pestañas*

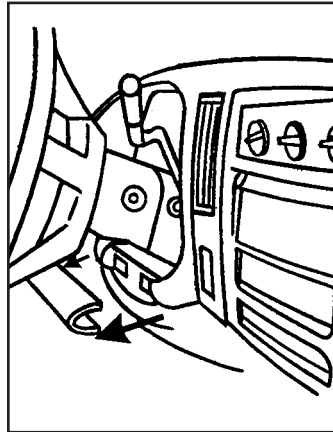

(Figura A)

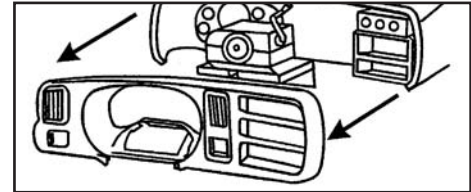

(Figura B)

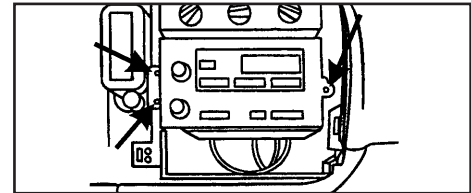

(Figura C)



## Desmontaje del tablero

### Chevrolet Express Van/ GMC Savana 2003-2007

1. Retire los (2) pernos de 10mm de debajo del soporte para rodillas abajo de la columna de dirección y retire el panel.
  2. Retire los (2) pernos de 10mm del panel debajo de la bolsa de aire del tablero del lado del pasajero y retire el panel.
  3. Retire las (2) tuercas de 10mm de la cavidad central interior entre los tomacorrientes.
  4. Suelte a presión y retire el panel del radio/conjunto de instrumentos.
  5. Retire los (3) pernos de 9/32" para retirar el radio.
- Nota: Tenga en cuenta que quizá no sea necesario retirar el radio y el panel del conjunto de instrumentos para obtener acceso al radio.*
- Continúe con las instrucciones para pestañas*

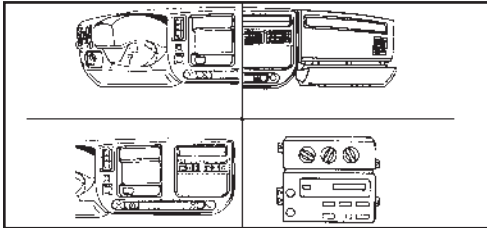

### Buick Roadmaster 1995-1996

1. Desenganche los lados del panel del tablero y retire.
  2. Desenganche el panel debajo de la columna de dirección y retire.
  3. Retire los (2) tornillos de 7mm de arriba del conjunto de instrumentos.
  4. Ponga el freno de mano, gire la llave a la posición de encendido y mueva la palanca de velocidades al cambio más bajo.
  5. Retire los (3) tornillos de 7mm para retirar el radio.
- Continúe con las instrucciones para pestañas*

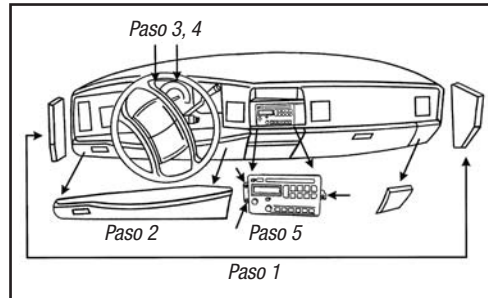

### Chevrolet Impala 2000-2005

1. Desenganche cada lado del bisel de la moldura del tablero (acceso a los fusibles) y retire (1) tornillo Phillips expuesto a cada lado.
  2. Retire (2) tornillos Phillips de abajo del conjunto de instrumentos.
  3. Desenganche el panel de la moldura sobre los pedales. No es necesario retirar el panel, puede dejarse colgando.
  4. Retire los (2) tornillos Phillips del panel para las rodillas.
  5. Desenganche el panel para las rodillas y retire (1) tornillo Phillips expuesto en el lado derecho de la columna de dirección.
  6. Desenganche y retire todo el bisel de la moldura del tablero.
- (Figura A)*
- Continúe con las instrucciones para pestañas*

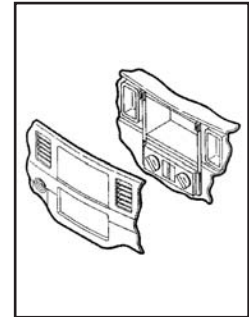

(Figura A)



## Desmontaje del tablero

### Chevrolet Malibu 2001-2003/Malibu Classic 2004

1. Suelte y retire el bisel del radio. (Figura A)
2. Retire los (3) pernos y retire el radio. (Figura A)

*Continúe con las instrucciones para pestañas*

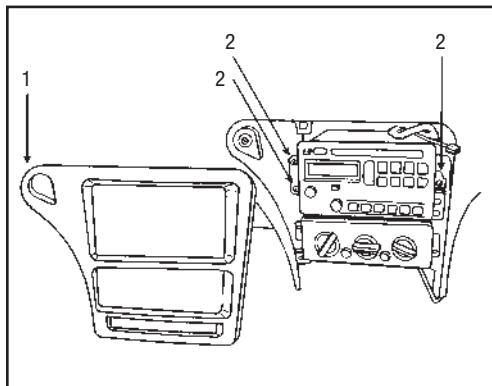

(Figura A)

### Chevrolet Metro/Suzuki Swift 1995-2001

1. Retire el cenicero y los (2) tornillos Phillips expuestos. (Figura A)
2. Retire los (2) tornillos Phillips de arriba de la apertura del radio. (Figura A)
3. Desenganche el bisel de la moldura del radio y desconecte el cableado del encendedor.
4. Retire los (2) tornillos que sujetan cada lado de la unidad central de fábrica y (1) tornillo del soporte trasero.
5. Deslice la unidad hacia afuera y desconecte el cableado.

*Continúe con las instrucciones para pestañas*

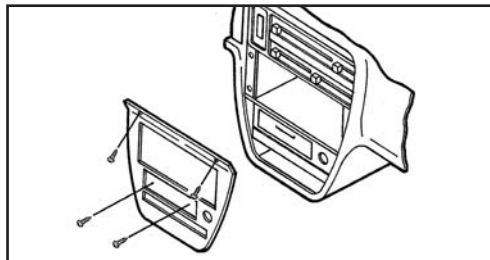

(Figura A)

### Chevrolet Monte Carlo 2000-2005

1. Desenganche el panel de la moldura sobre los pedales. NO es necesario retirar el panel, puede dejarse colgando.
2. Retire los (2) tornillos de 9/32" del panel para las rodillas y desenganche el panel.
3. Suelte a presión la cubierta del panel de fusibles del lado del conductor y retire (1) tornillo de 9/32".
4. Abra la guantera y retire (1) tornillo de 9/32" de la esquina superior izquierda.
5. Retire los (3) tornillos de 9/32" que sujetan la unidad central de fábrica y desconecte el cableado.

*Continúe con las instrucciones para pestañas*

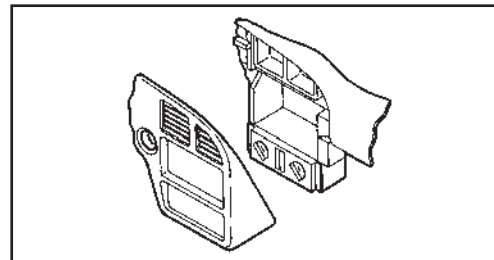



## Desmontaje del tablero

### Chevrolet SSR 2003-2006

1. Suelte y retire las (3) perillas de control del clima. (Figura A)
2. Suelte y retire el panel largo de moldura debajo del radio y de la bolsa de aire del pasajero. (Figura B)
3. Desenganche y retire el panel de moldura pequeño a la izquierda del volante. (Figura C)
4. Retire los (5) tornillos de 9/32" que sujetan el radio/panel de instrumentos y luego desenganche y retire el panel. (Figura D)
5. Retire los tornillos que sujetan la unidad central de fábrica y desconecte el cableado.

*Continúe con las instrucciones para pestañas*

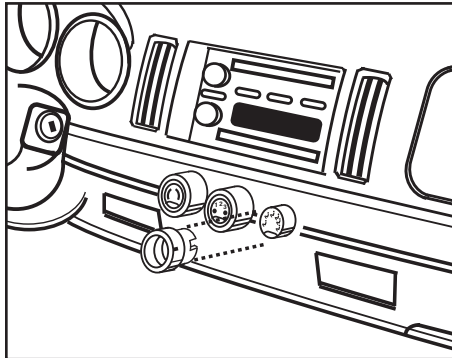

(Figura A)

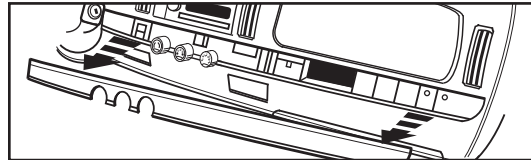

(Figura B)

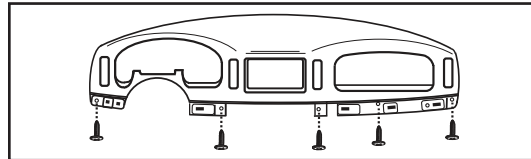

(Figura D)

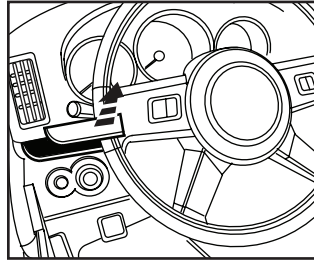

(Figura C)

### Chevrolet Tracker 1992-2004, Suzuki Sidekick 1992-1998, Vitara 1999-2005/Grand Vitara 1999-2002/XL-7 2001-2002

1. Retire el encendedor y las perillas de control del clima.
2. Retire el cenicero y (1) tornillo expuesto. (Figura A)
3. Jale el conjunto de control del clima y retire los (2) tornillos expuestos. (Figura B)
4. Desenganche el bisel de la moldura del radio. (Figura A)
5. Retire los (4) tornillos de la unidad central de fábrica, deslice la

unidad hacia fuera y desconecte el cableado.

*Continúe con las instrucciones para pestañas*

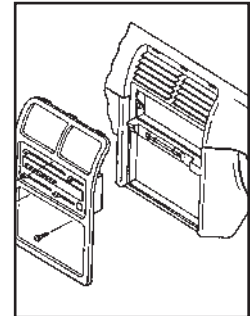

(Figura A)



## Desmontaje del tablero

### Chevrolet Trailblazer 2002-2009

1. Retire los (2) tornillos Phillips del interior del conjunto de instrumentos.
2. Retire (1) tornillo Phillips debajo de los controles del clima a la izquierda del tomacorriente.
3. Retire los (2) tornillos de cabeza hexagonal de 7mm debajo de la columna de dirección y baje el panel.
4. Retire los (3) tornillos Phillips de alrededor del volante.
5. Suelte a presión y retire el bisel (tenga cuidado al jalarlo sobre el interruptor de las luces intermitentes).
6. Retire los (3) tornillos de cabeza hexagonal de 7mm para retirar el radio.

*Continúe con las instrucciones para pestañas*

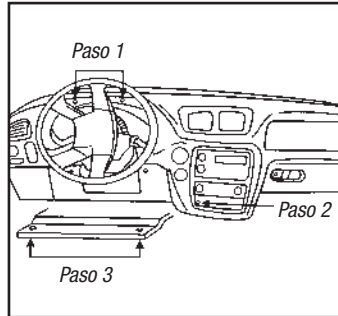
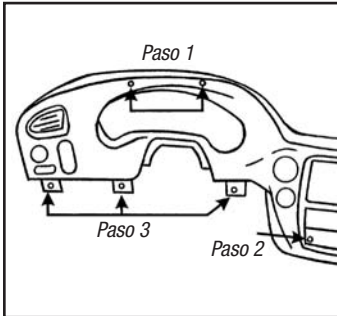

### Chevrolet Venture/ Oldsmobile Silhouette/ Pontiac Montana (excepto SV6) 2000

1. Retire el cenicero y (1) tornillo Phillips expuesto en la cavidad del cenicero.
2. Retire (1) tornillo Phillips del compartimiento del encendedor.
3. Retire los (2) tornillos Phillips que sujetan la unidad central de fábrica y desconecte el cableado.

*Continúe con las instrucciones para pestañas*

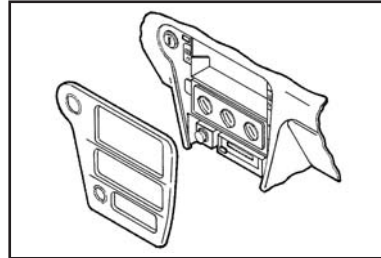

### Chevrolet Venture/ Pontiac Montana (excepto SV6) 2001- 2005/Oldsmobile Silhouette 2001-2004

1. Retire el cenicero y (1) tornillo Phillips expuesto en la cavidad del cenicero.
2. Retire (1) tornillo Phillips del compartimiento del encendedor.
3. Retire los (2) tornillos Phillips que sujetan la unidad central de fábrica y desconecte el cableado.

*Continúe con las instrucciones para pestañas*

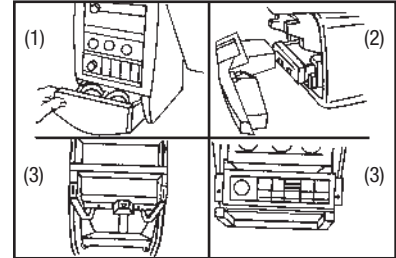



## Desmontaje del tablero

### GMC Envoy 2002-2009, Isuzu Ascender 2003-2009, Oldsmobile Bravada 1998-2004, Buick Rainier 2004-2007

1. Retire los (4) tornillos Phillips, (2) de la izquierda y (2) de la derecha del panel alfombrado. (Figura A)
2. Deslice el panel alfombrado hacia abajo y hacia atrás para revelar los (2) tornillos Phillips y retire. (Figura B)
3. Suelte a presión el bisel del radio y desconecte el encendedor y los accesorios. (Figura C)
4. Retire los (3) tornillos y retire el radio. (Figura C)

*Continúe con las instrucciones para pestañas*

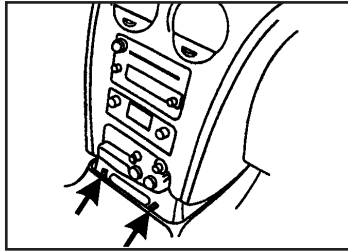

(Figura B)

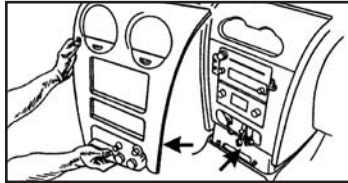

(Figura C)

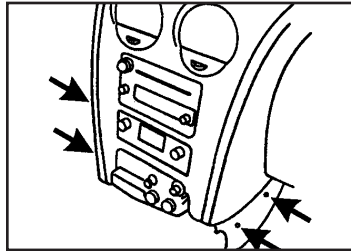

(Figura A)

### Hummer H2 2003-2007

1. Abra la consola central y retire los (4) tornillos de 9/32" de la caja de la consola y retire la caja. (Figura A)
2. Retire los (4) tornillos Phillips de la bisagra sobre la puerta de la consola al interior de la misma y retire la puerta. (Figura B)
3. Afloje (1) tornillo Torx T-15 en el lado orientado hacia el frente de la palanca de velocidades y jale hacia arriba para retirar. (Figura C)
4. Desenganche el ensamble de la moldura del portavasos/palanca de velocidades y retire. (Figura 4)

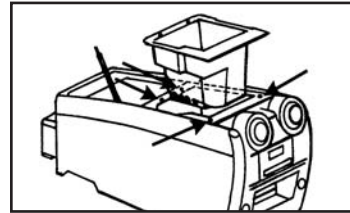

(Figura A)

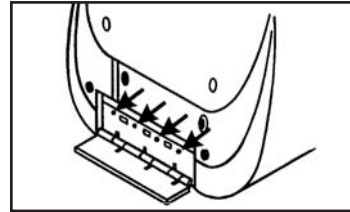

(Figura B)

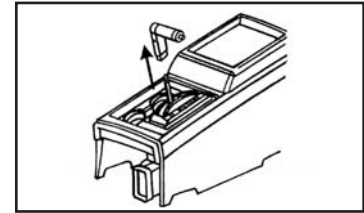

(Figura C)

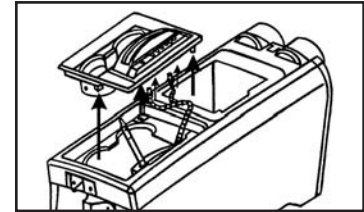

(Figura D)



## Desmontaje del tablero

### Hummer H2 2003-2007

5. Retire los (6) tornillos Phillips de la parte superior de la consola central. (Figura E)
6. Retire los (2) tornillos Phillips de la cavidad interior en la parte posterior de la consola central, luego desenganche y retire. (Figura F)
7. Retire (1) perno de 10mm a la derecha de la palanca de velocidades.
8. Retire los (2) tornillos Phillips debajo de la caja de la consola del lado del conductor y (2) tornillos Phillips debajo de la parte superior de la moldura de la consola en el lado del pasajero.
9. Deslice el ensamble del control hacia atrás.
10. Retire los (2) pernos Torx T-30 de la parte superior de la moldura del radio/control de clima y desenganche y retire. (Figura G)
11. Retire los (3) tornillos de 9/32" que sostienen el radio dentro. (Figura G)

*Continúe con las instrucciones para pestañas*

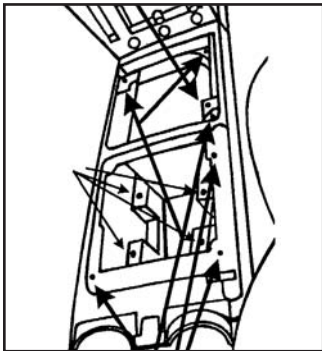

(Figura E)

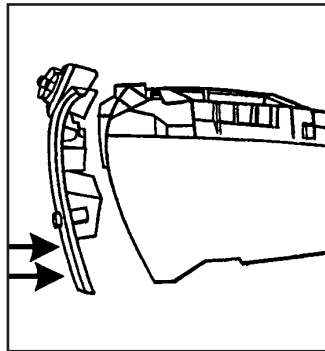

(Figura F)

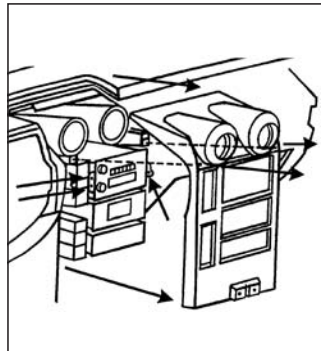

(Figura G)

### Oldsmobile Achieva 1996-1998

1. Abra la guantera, presione hacia dentro las paredes del revestimiento de la guantera y retire el revestimiento.
2. Retire los (10) tornillos de cabeza Torx de la guantera.
3. Retire los (2) tornillos de cabeza hexagonal de 9/32" debajo de la columna de dirección.
4. Desenganche el bisel de la moldura del tablero.
5. Retire los tornillos que sujetan la unidad central de fábrica y desconecte el cableado.

*Continúe con las instrucciones para pestañas*

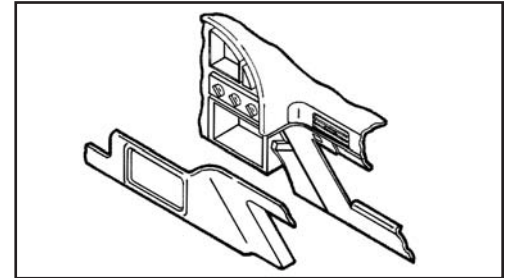

(Figura A)



## Desmontaje del tablero

### Oldsmobile Cutlass 1997-1999, Cutlass Supreme 1995-1997

1. Desenganche el bisel de la moldura del radio y retire. (Figura A)
2. Retire los (2) tornillos de cabeza hexagonal de 9/32" que sujetan la unidad central de fábrica y desconecte el cableado.

*Continúe con las instrucciones para pestañas*

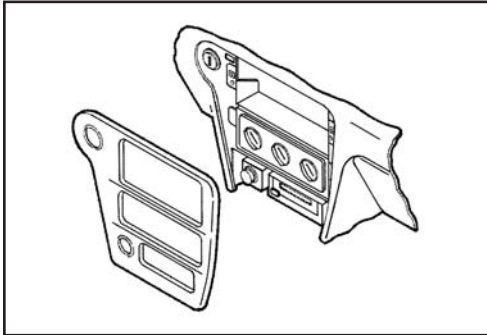

(Figura A)

### Oldsmobile Alero 1999-2004

1. Retire la perilla de la palanca de velocidades con un pequeño destornillador para retirar el gancho en U de la parte frontal de la palanca de velocidades y jale hacia arriba.
2. Suelte y retire el panel de moldura de la palanca de velocidades.
3. Desenganche y retire el panel del radio y el control del clima jalando desde abajo. (Figura A)
4. Retire los (3) tornillos de 9/32" del radio y retire.

*Continúe con las instrucciones para pestañas*

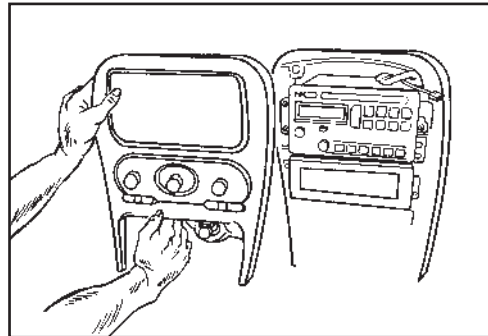

(Figura A)

### Oldsmobile Aurora 1995-2003

1. Desenganche el bisel de la moldura del radio y retire el bisel. (Figura A)
2. Retire los (2) tornillos de 7mm que sujetan la unidad central de fábrica y desconecte el cableado.

*Continúe con las instrucciones para pestañas*

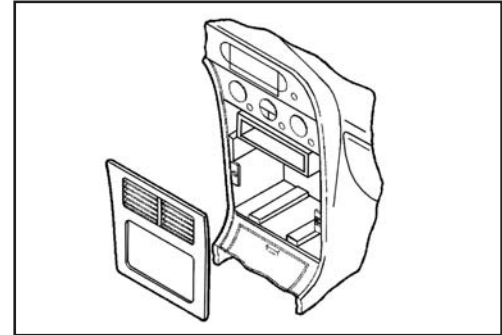

(Figura A)





## Desmontaje del tablero

### Oldsmobile Eighty Eight 1994-1999

1. Desenganche el bisel de la moldura del radio y retire. (Figura A)
2. Retire los (2) tornillos de cabeza hexagonal de 9/32" que sujetan la unidad central de fábrica y desconecte el cableado.

*Continúe con las instrucciones para pestañas*

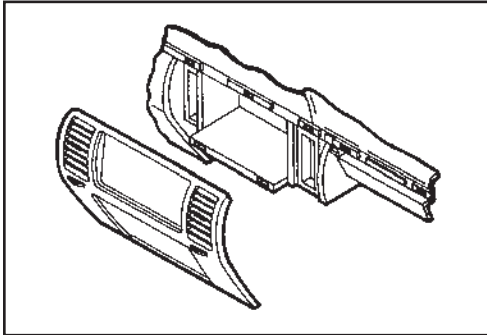

(Figura A)

### Oldsmobile Ninety Eight 1994-1996

1. Abra la guantera y retire los (2) tornillos de cabeza hexagonal que sujetan la moldura de madera.
2. Suelte a presión la moldura de madera y retire.
3. Retire los (2) tornillos de cabeza hexagonal debajo del bisel de la moldura del radio.
4. Levante el bisel y retírelo. (Figura A)
5. Retire los (3) tornillos Phillips de cabeza hexagonal que sujetan la unidad central de fábrica y desconecte el cableado.

*Continúe con las instrucciones para pestañas*

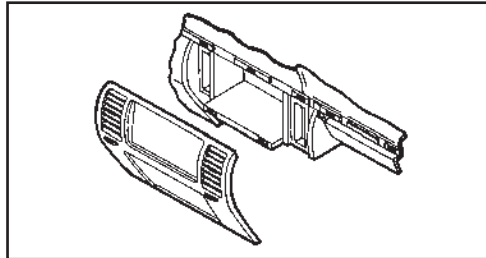

(Figura A)

### Oldsmobile Intrigue 1998-2003

1. Abra el compartimiento de almacenamiento de la consola central y retire los (2) tornillos de cabeza hexagonal de 9/32" expuestos.
2. Retire la consola central.
3. Desenganche el bisel de la moldura del radio y retire. (Figura A)
4. Retire los (2) tornillos de cabeza hexagonal de 9/32" que sujetan la unidad central de fábrica y desconecte el cableado.

*Continúe con las instrucciones para pestañas*

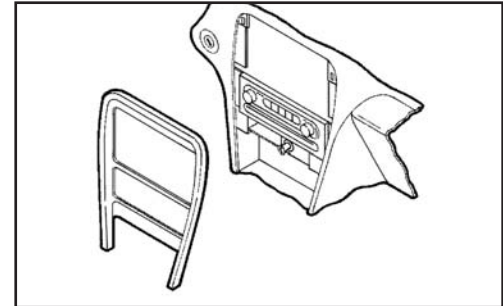

(Figura A)



## Desmontaje del tablero

### **Honda Passport 1998-2002, Isuzu Amigo 1998-2000, Rodeo 1998-2004, Rodeo Sport 2001-2003**

1. Retire el cenicero y (1) tornillo Phillips expuesto en la cavidad del cenicero.
2. Desenganche y retire el panel de moldura que rodea el radio de fábrica. (Figura A)
3. Retire los (4) tornillos Phillips que sujetan el radio de fábrica y desconecte el cableado.

*Continúe con las instrucciones para pestañas*

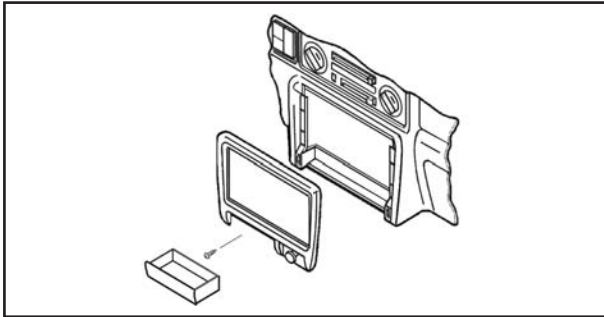

(Figura A)

### **Oldsmobile L55 1996-1999 Regency 1997-1998**

1. Abra la guantera y retire dos biseles de moldura centrales unidos con tornillos. (Figura A)
2. Suelte y retire el bisel de la moldura del radio. (Figura A)
3. Retire los (3) tornillos de cabeza hexagonal de 9/32" y retire el radio. (Figura B)

*Continúe con las instrucciones para pestañas*

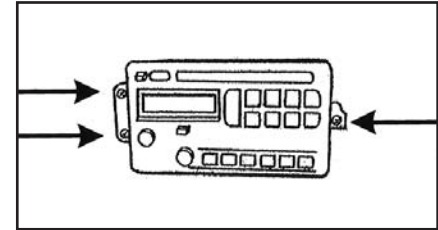

(Figura B)

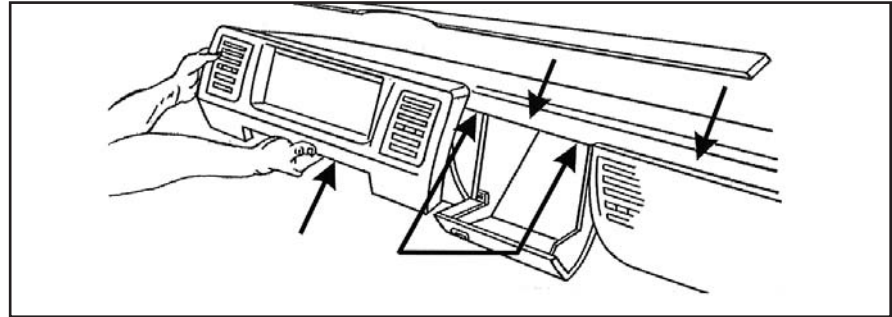

(Figura A)



## Desmontaje del tablero

### Pontiac Aztec 2001-2005

1. Jale y saque los insertos de los portavasos.
2. Retire (1) tornillo Phillips expuesto del interior del portavasos.
3. Suelte a presión y retire la moldura de la palanca de velocidades con los portavasos.
4. Retire los (2) tornillos Torx #15 de la parte inferior del bisel del radio/clima.

*Continúe con las instrucciones para pestañas*

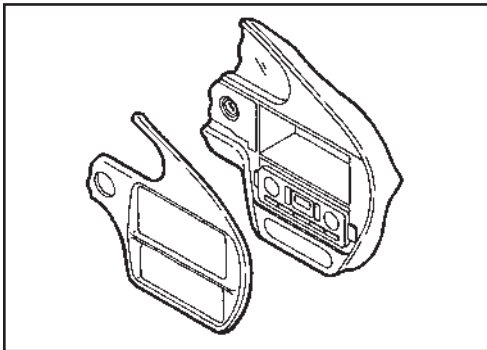

### Pontiac Bonneville 2000-2005

1. Retire los (2) tornillos Phillips del conjunto de instrumentos. (Figura A)
2. Desenganche la moldura de la ignición y retire. (Figura B)
3. Desenganche el bisel del control de clima/moldura del radio y retire.
4. Apriete los ganchos de resorte a cada lado de la unidad central de fábrica y retire. (Figura C)

*Continúe con las instrucciones para pestañas*

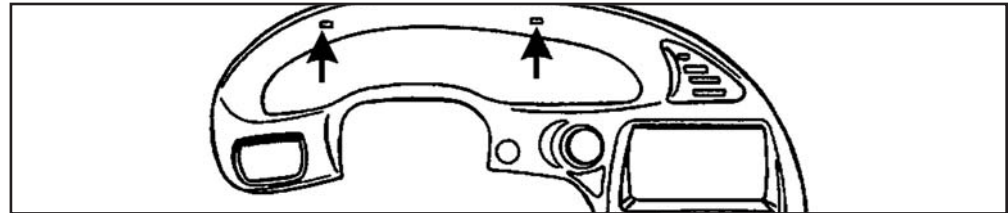

(Figura A)



(Figura B)

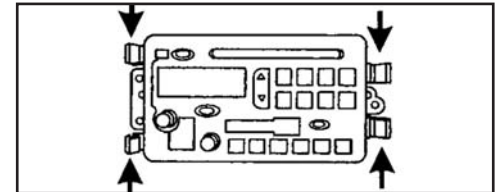

(Figura C)



## Desmontaje del tablero

### Pontiac Grand Am 2001-2005

1. Suelte y retire el bisel de la moldura del radio.
2. Retire los (3) tornillos de 9/32" de los soportes del radio y retire el radio.

*Continúe con las instrucciones para pestañas*

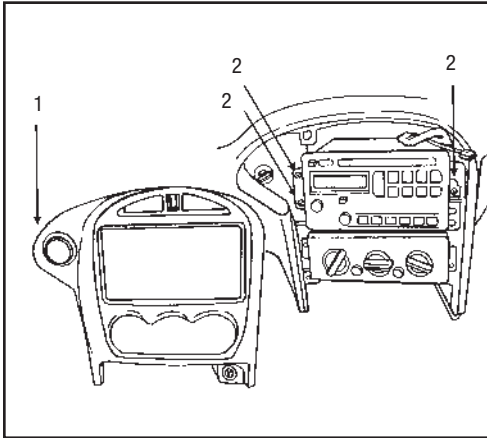

### Pontiac Sunfire 2000-2005

1. Abra la guantera y retire (2) tornillos Phillips expuestos en el borde superior derecho del bisel de la moldura del radio.
2. Desenganche el bisel y retire. (Figura A)
3. Retire los (2) tornillos de cabeza hexagonal de 7mm que sujetan la unidad central de fábrica y desconecte el cableado.

*Continúe con las instrucciones para pestañas*

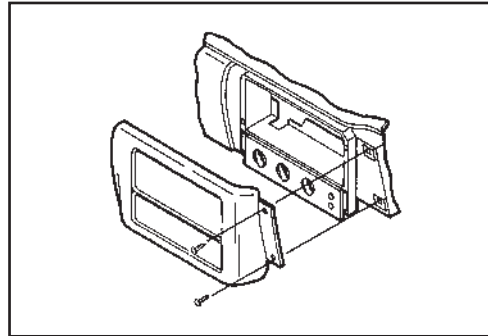

(Figura A)

### Toyota Matrix 2003-2004/Pontiac Vibe 2003-2008

1. Desenganche el borde inferior del panel de la moldura del radio y luego levante y retire. (Figura A)

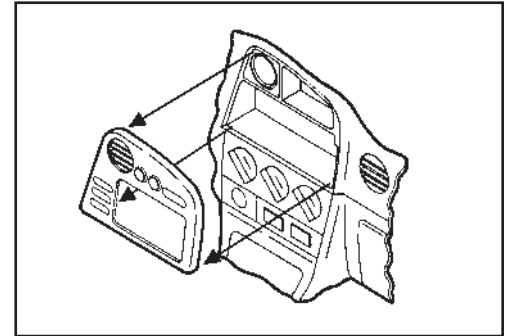

(Figura A)



## Desmontaje del tablero

### Toyota Matrix 2003-2004/Pontiac Vibe 2003-2008

2. Retire los (4) pernos de 10mm que sujetan el radio de fábrica. (Figura B)

*Continúe con las instrucciones para pestañas*

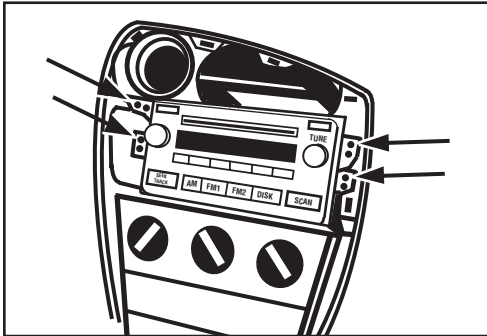

(Figura B)

### Suzuki Aerio 2002

1. Desenganche el bisel de la moldura del tablero y retire. (Figura A)
2. Retire los (4) tornillos Phillips que sujetan la unidad central de fábrica y desconecte el cableado.

*Continúe con las instrucciones para pestañas*

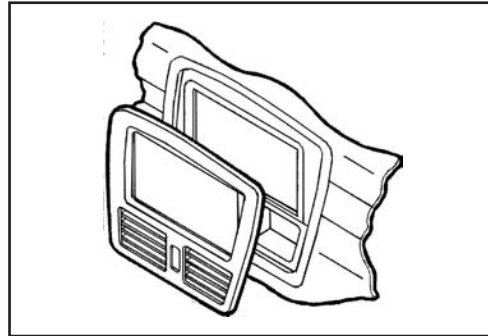

(Figura A)

### Suzuki Esteem 1995-2003

1. Retire las perillas del control de clima.
2. Retire (1) tornillo Phillips localizado arriba de la apertura del radio. (Figura A)
3. Desenganche el bisel de la moldura del radio. (Figura A)
4. Retire los (4) tornillos de la unidad central de fábrica, deslice la unidad hacia fuera y desconecte el cableado.

*Continúe con las instrucciones para pestañas*

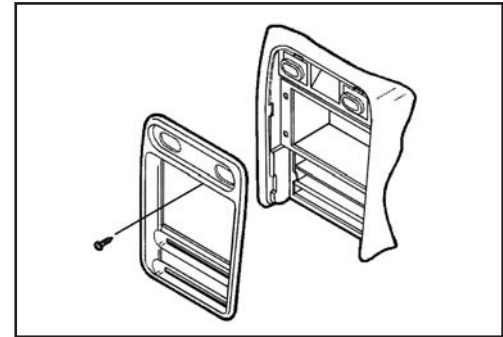

(Figura A)



## Instrucciones las pestañas 95-2009

### Instrucciones las pestañas

#### 1. Vehículos GM

Corte las pestañas marcadas en ambos lados de los soportes. (Figura A)

#### 2. Chevy Tracker/Metro/Suzuki

Corte las pestañas marcadas en ambos lados de los soportes. (Figura B)

#### 3. Cadillac Fleetwood/Brougham

Cut all tabs highlighted on both sides of both brackets. (Figura C)

#### 4. Isuzu Amigo/Rodeo/Rodeo Sport

Corte las pestañas marcadas. (Figura D)

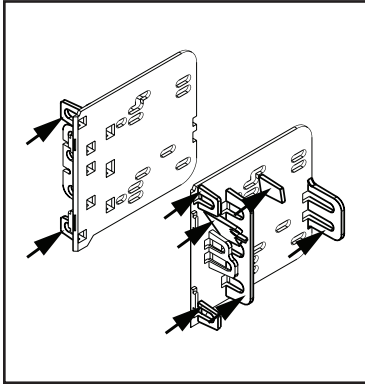

(Figura A)

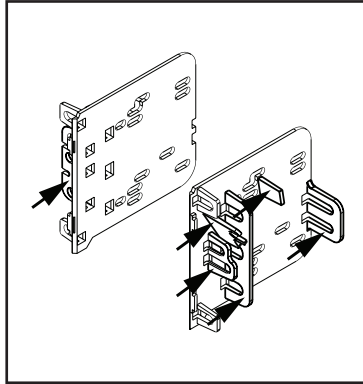

(Figura B)

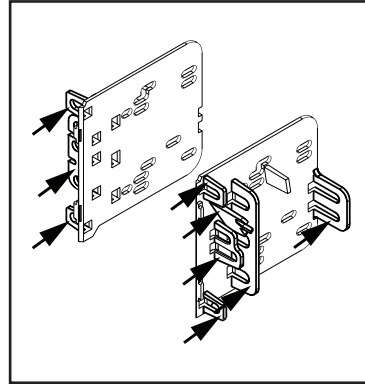

(Figura C)

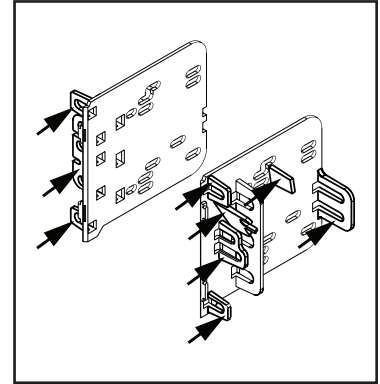

(Figura D)

## Instrucciones las pestañas

### 5. Toyota Matrix/Pontiac Vibe

Corte las pestañas marcadas. (Figura E)

Corte las (4) pestañas marcadas en la placa de moldura doble DIN. (Figura F)

### 6. Cadillac Eldorado/Seville

Corte las pestañas marcadas en los soportes doble DIN. (Figura G)

Corte (1) pestaña marcadas en la esquina superior izquierda de la placa de moldura doble DIN. (Figura H)

*Continuará al ensamble del kit*

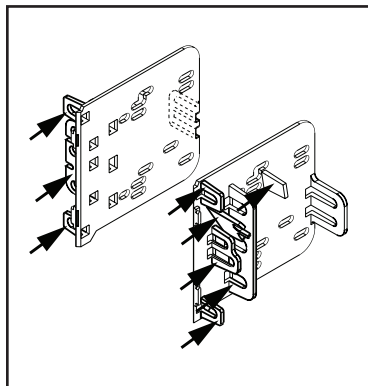

(Figura E)

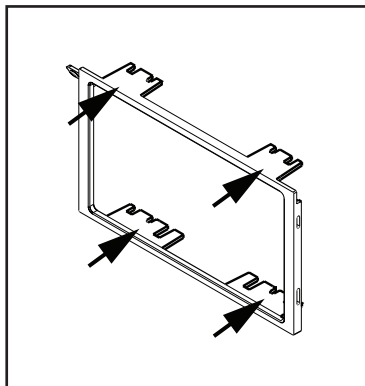

(Figura F)

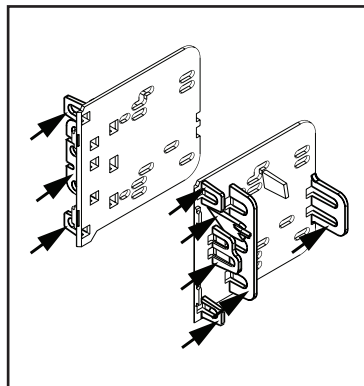

(Figura G)

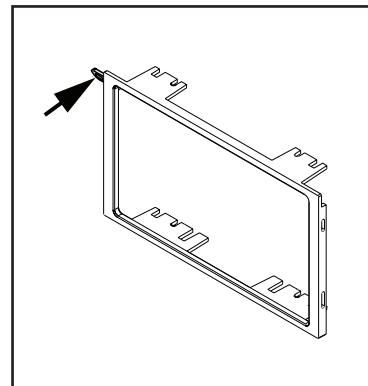

(Figura H)

## Cadillac Fleewood/Brougham 1990-1996

(con soportes de montaje)

1. Con los pernos cabeza de hongo y las tuercas keps suministrados, monte los soportes de fábrica al ensamble de la placa de moldura doble DIN/suporte doble DIN (recuerde cuál soporte va arriba y cuál es el de abajo). (Figura A)

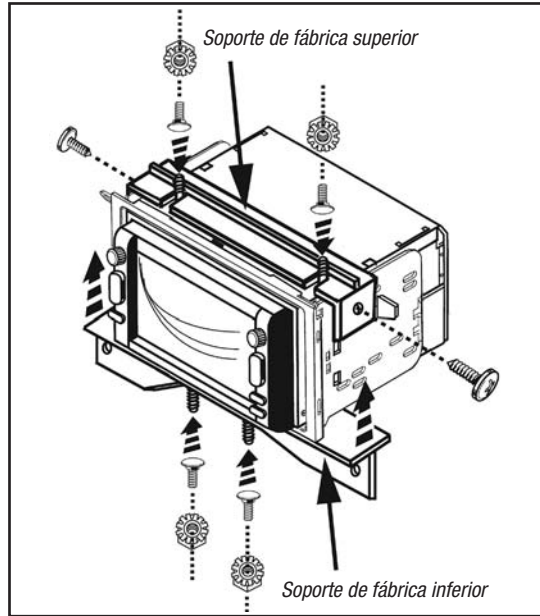

(Figura A)

## Cadillac Eldorado/Seville 1992-1995

1. Alinee las pestañas en la parte inferior de la placa de moldura doble DIN con las muescas del sub tablero. (Figura A)
2. Sujete con los (2) pernos cabeza de hongo y las (2) tuercas keps suministrados. (Figura A)

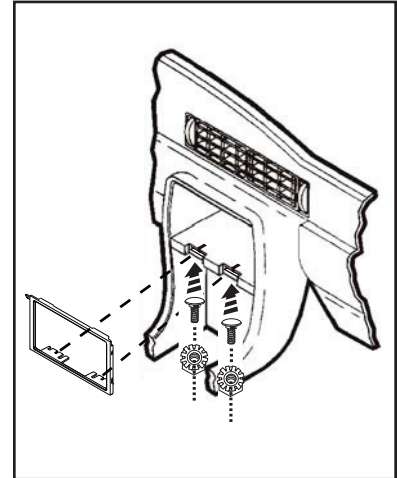

(Figura A)





## Ensamble del kit 95-2009

### Provisión de radio doble DIN/de unidades ISO verticales

1. Coloque a presión los soportes doble DIN en el borde de la placa de la moldura doble DIN.
2. Deslice la unidad central Doble DIN o las unidades centrales ISO verticales en el ensamble del soporte/carcasa del radio y sujete la unidad central Doble DIN o las unidades centrales ISO verticales en el ensamble utilizando los tornillos suministrados con el radio.

**Nota:** Para el Buick LeSabre, Oldsmobile Aurora y el Pontiac Bonneville, los (3) ganchos de velocidad y tornillos suministrados con el kit deberán instalarse en el sub tablero donde los orificios se alinean con el kit.

3. Ubique el arnés del cableado de fábrica en el tablero. Metra recomienda usar el adaptador de acoplamiento adecuado de Metra o AXXESS. Vuelva a conectar el terminal negativo de la batería y pruebe la unidad para verificar que funcione correctamente.
4. Vuelva a montar el tablero en forma inversa al desmontaje.

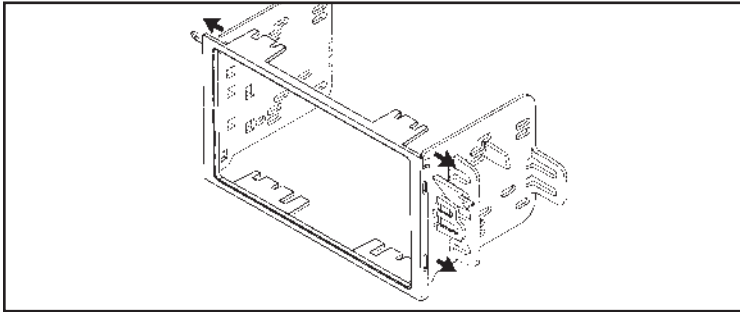

(Figura A)

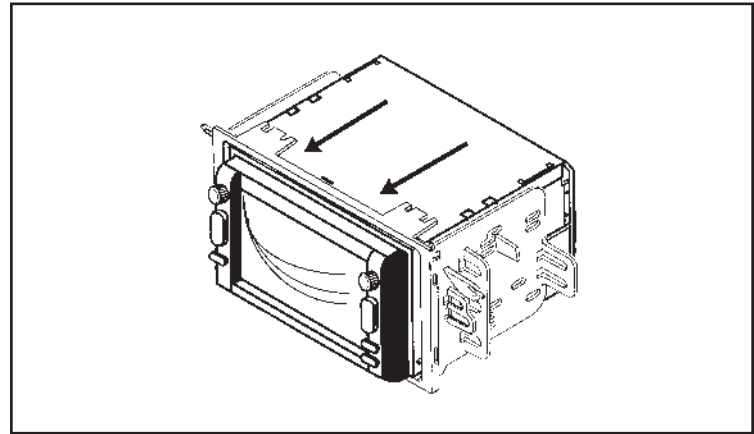

(Figura B)



## Instrucciones las pestañass 99-2009

### Instrucciones las pestañass

#### 1. Vehículos GM

Corte las pestañas marcadas en ambos lados de la carcasa del radio. (Figura A)

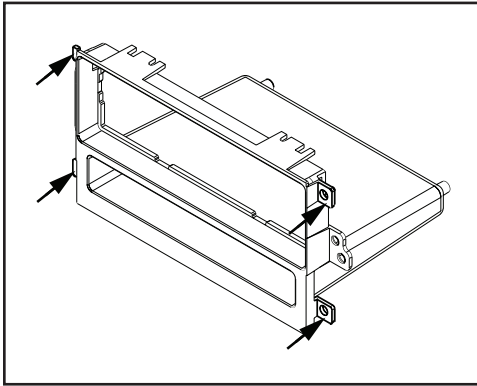

(Figura A)

#### 2. Chevy Tracker/Metro/Suzuki

Corte las pestañas marcadas en ambos lados de la carcasa del radio. (Figura B)

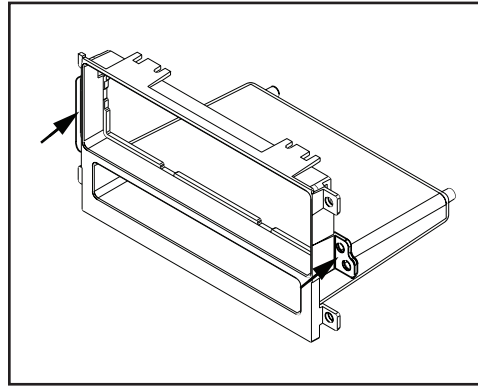

(Figura B)

#### 3. Cadillac Fleetwood/Brougham

Corte todas las pestañas marcadas en ambos lados de la carcasa del radio. (Figura C)

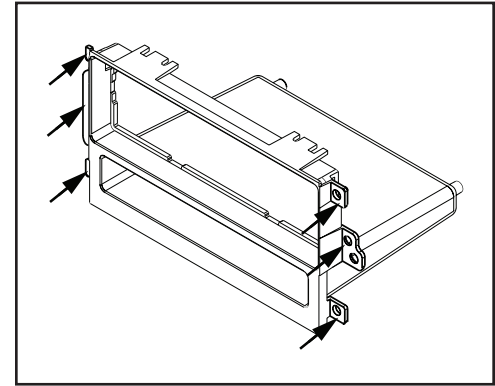

(Figura C)

## Instrucciones las pestañas

### 4. Isuzu Amigo/Rodeo/Rodeo Sport

Corte las pestañas marcadas en ambos lados de los soportes. (Figura D)

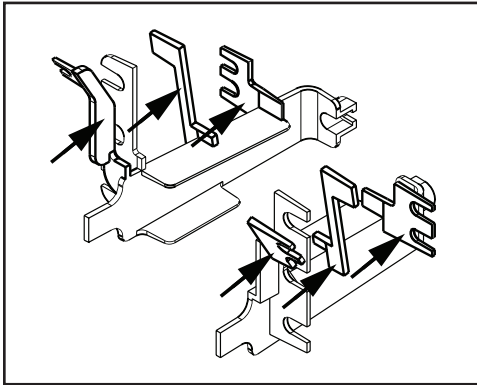

(Figura D)

### 5. Toyota Matrix/Pontiac Vibe

Corte las pestañas marcadas en ambos lados de los soportes.

Corte las (4) pestañas marcadas en la placa de moldura doble DIN. (Figura E)

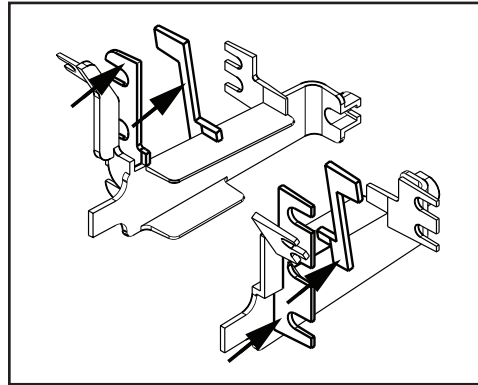

(Figura E)

### 6. Cadillac Eldorado/Seville

Corte las pestañas marcadas en ambos lados de los soportes. (Figura F)

*Continuará al ensamble del kit*

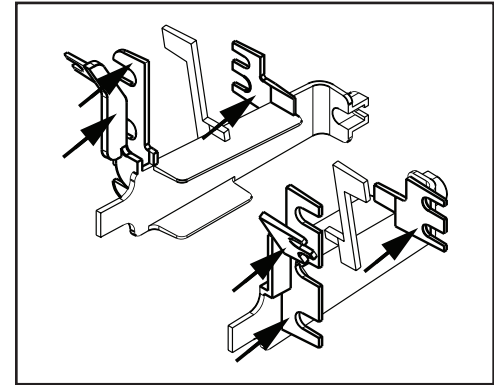

(Figura F)

## Cadillac Fleewood/Brougham 1990-1996

(con soportes de montaje)

1. Después de montar los (2) soportes laterales de la carcasa del radio suministrados a la carcasa del radio, utilizando (2) tornillos Phillips #8 de 3/8", monte el soporte de fábrica inferior en el ensamble de la carcasa del radio/soporte con los (2) pernos cabeza de hongo y las (2) tuercas keps suministradas. (Figura A)

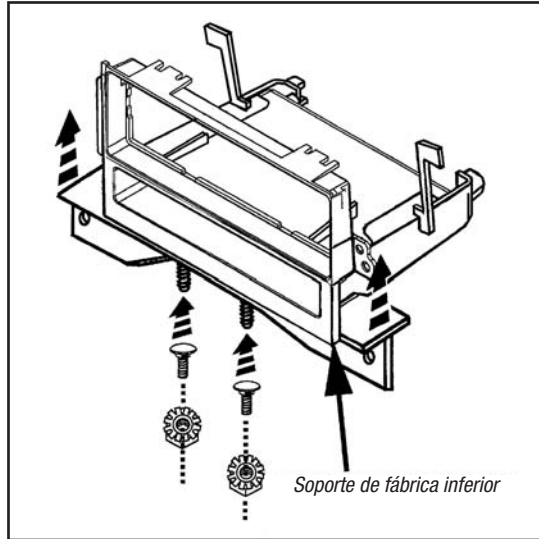

(Figura A)

## Cadillac Eldorado/Seville

1992-1995 (con soportes de montaje)

1. Alinee las pestañas en la parte inferior del soporte de fábrica inferior con las muescas del sub tablero.
2. Sujete con los (2) pernos cabeza de hongo y las (2) tuercas keps suministrados. (Figura A)

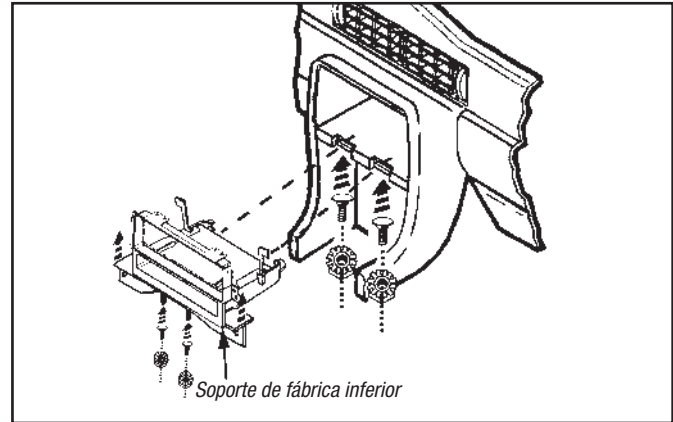

(Figura A)



## Ensamble del kit 99-2009

### Provisión de radio ISO con bolsillo

1. Corte las barras de soporte de la carcasa del radio y retire. (Figura A)
2. Deslice los soportes de la carcasa del radio en el bolsillo y sujete con los (2) tornillos #8 de 3/8" suministrados. (Figura B)
3. Monte los soportes ISO en la unidad central con los tornillos incluidos con la unidad. (Figura C)
4. Deslice la unidad central en la apertura del radio

hasta que los ganchos laterales se enganchen. (Figura D)

5. Coloque a presión la placa de la moldura en la carcasa del radio DIN sencilla. (Figura D)

**Nota:** Para el Buick LeSabre, Oldsmobile Aurora y el Pontiac Bonneville, los (3) ganchos de velocidad y tornillos suministrados con el kit deberán instalarse en el sub tablero donde los orificios se alinean con el kit.

6. Ubique el arnés del cableado de fábrica en el tablero. Metra recomienda usar el adaptador de acoplamiento adecuado de Metra o AXCESS. Vuelva a conectar el terminal negativo de la batería y pruebe la unidad para verificar que funcione correctamente.
7. Vuelva a montar el tablero en forma inversa al desmontaje.

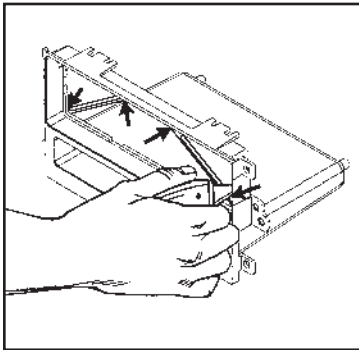

(Figura A)

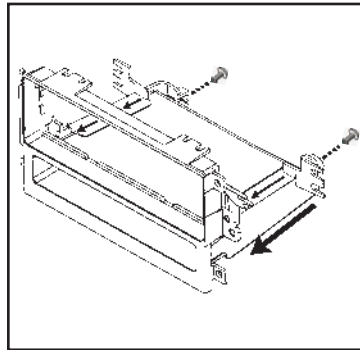

(Figura B)

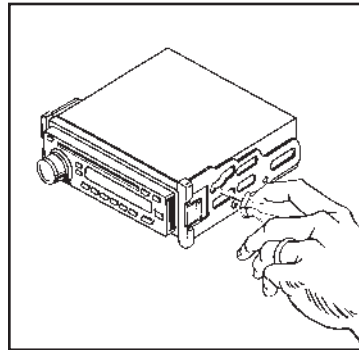

(Figura C)

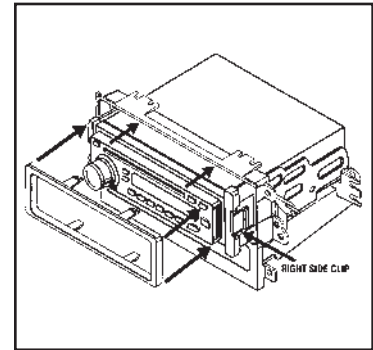

(Figura D)



## Ensamble del kit 99-2009

### Provisión de radio doble DIN con bolsillo

1. Corte las barras de soporte de la carcasa del radio y retire. (Figura A)

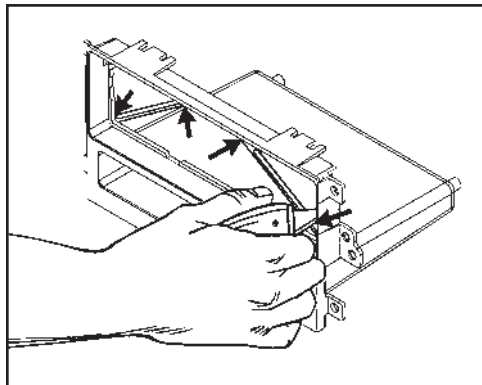

(Figura A)

2. Deslice los soportes de la carcasa del radio en el bolsillo y sujete con los (2) tornillos #8 de 3/8" suministrados. (Figura B)

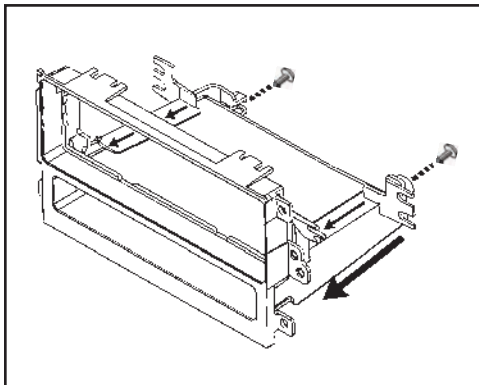

(Figura B)

3. Deslice la reja DIN en la carcasa del radio y sujétela doblando hacia abajo las pestañas de metal. (Figura C)

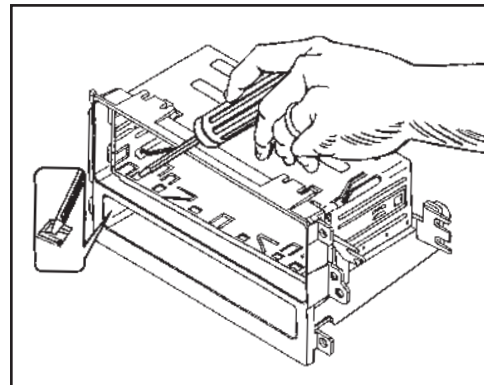

(Figura C)

**Provisión de radio doble DIN con bolsillo****Notas**

4. Deslice la unidad central de mercado secundario en la reja y sujétela. (Figura D)

**Nota:** (1) Para el Buick LeSabre, Oldsmobile Aurora y el Pontiac Bonneville, los (3) ganchos de velocidad y tornillos suministrados con el kit deberán instalarse en el sub tablero donde los orificios se alinean con el kit.

(2) Se ha suministrado un espaciador DIN a presión para algunas aplicaciones en las que la profundidad es un problema. Coloque el espaciador en la carcasa y deslice la jaula DIN en el ensamble y sujétela doblando hacia abajo las pestañas de metal. (Figura E)

5. Ubique el arnés del cableado de fábrica en el tablero. Metra recomienda usar el adaptador de acoplamiento adecuado de Metra o AXXESS. Vuelva a conectar el terminal negativo de la batería y pruebe la unidad para verificar que funcione correctamente.
6. Vuelva a montar el tablero en forma inversa al desmontaje.

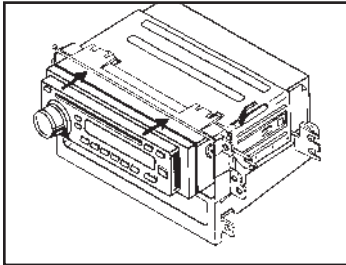

(Figura D)

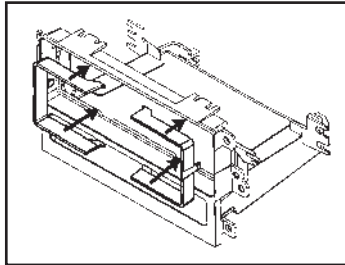

(Figura E)

---

---

---

---

---

---

---

---

---

---

---

---

---

---

---

---

---

---

---

---

---

---

---

---

---

---

---

---

---

---



## INSTRUCCIONES DE INSTALACIÓN PARA LA PIEZA 95-2009 o 99-2009



REV. 9/19/2013 INST-2009



**EL CONOCIMIENTO ES PODER**  
Mejore sus habilidades de instalación y fabricación inscribiéndose en la escuela de dispositivos electrónicos móviles más reconocida y respetada de nuestra industria. Regístrese en [www.installerinstitute.com](http://www.installerinstitute.com) o llame al 800-354-6782 para obtener más información y avance hacia un futuro mejor.



**Metra recomienda técnicos con certificación del Programa de Certificación en Electrónica Móvil (Mobile Electronics Certification Program, MECP).**