

Procédure de montage d'un système de navigation dans une Subaru Forester.

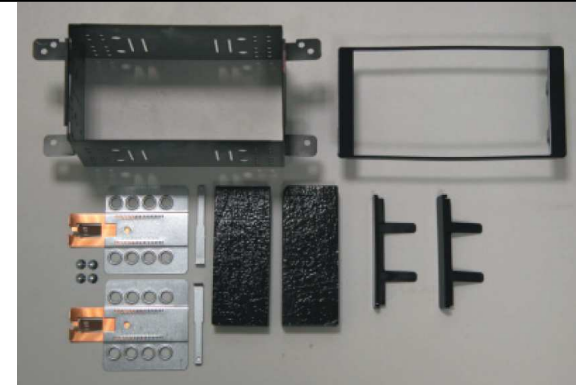

Pièces Pioneer

Kit 2 Din : Noir
réf : 12-301286-04



Interface électrique
réf : CA-R-SU199HA

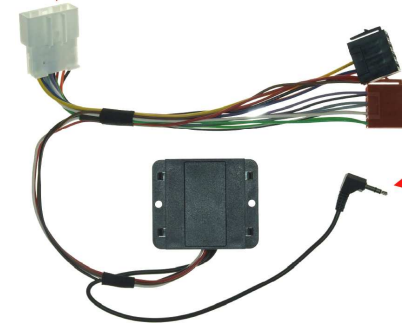

Dépose de l'autoradio d'origine

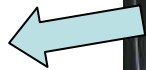

Déclipser l'enjoliveur de la face avant

Sorter l'autoradio en dévissant les 4 vis



Installation de l'antenne GPS



*Coller la plaque
métallique de
l'antenne GPS sur la
bouche d'air derrière
l'autoradio.*



Connexions des fils

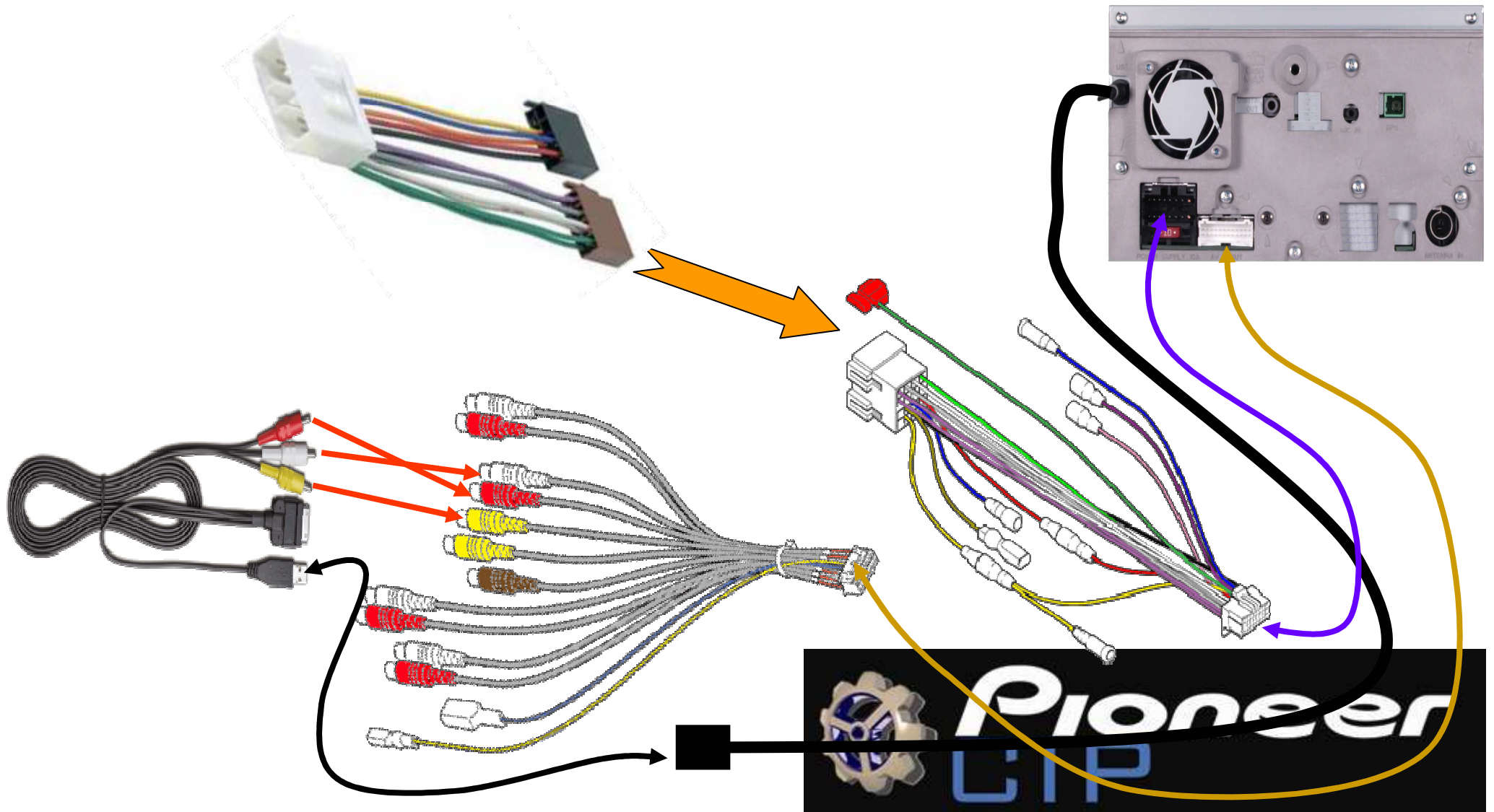

Connexions des

Signal de vitesse epissure, soudure, isolation, du fil **Rose Pioneer** *CAR* **SPEED SIGNAL INPUT** sur le connecteur blanc à 40 broches, cavité 31, fil **Rose / liseré Vert**

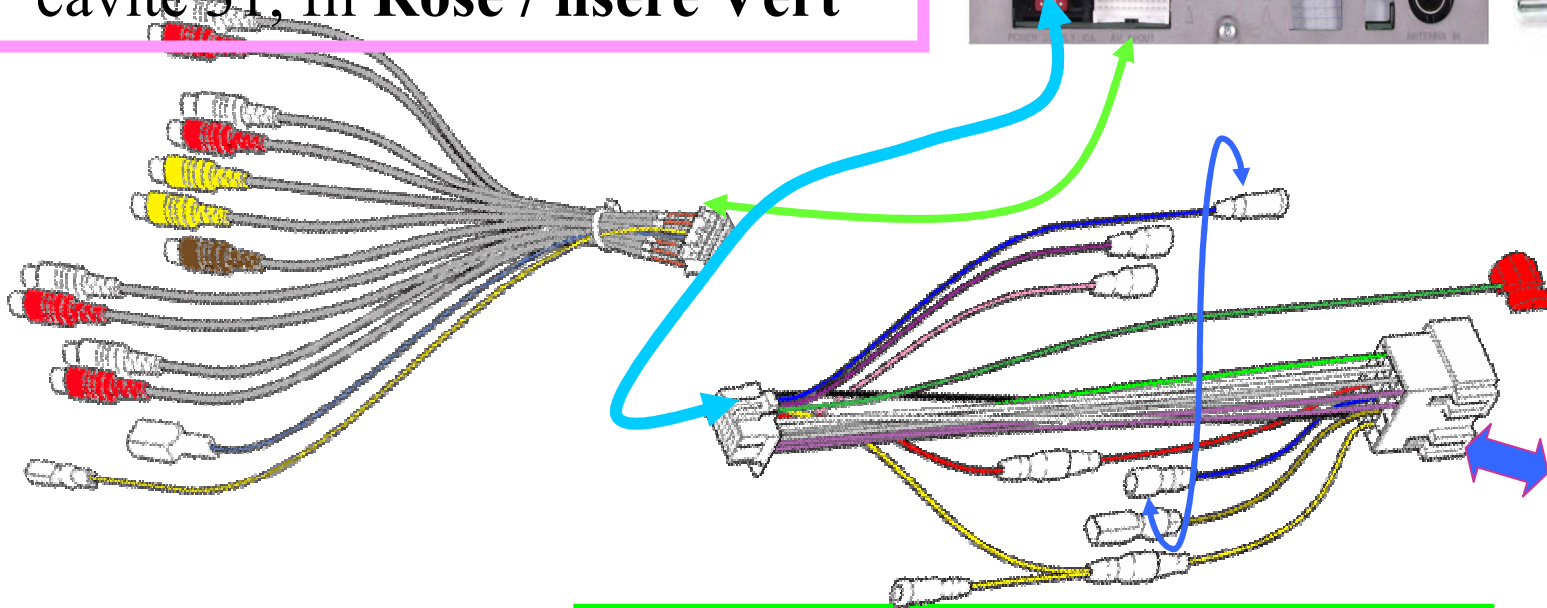
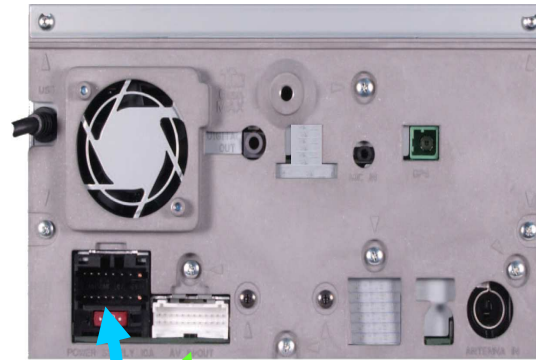

Signal sécurité

Fil Mauve/Rouge du contacteur frein à main avec le fil Vert Pioneer

PARKING BRAKE



Connexion du fil frein à main

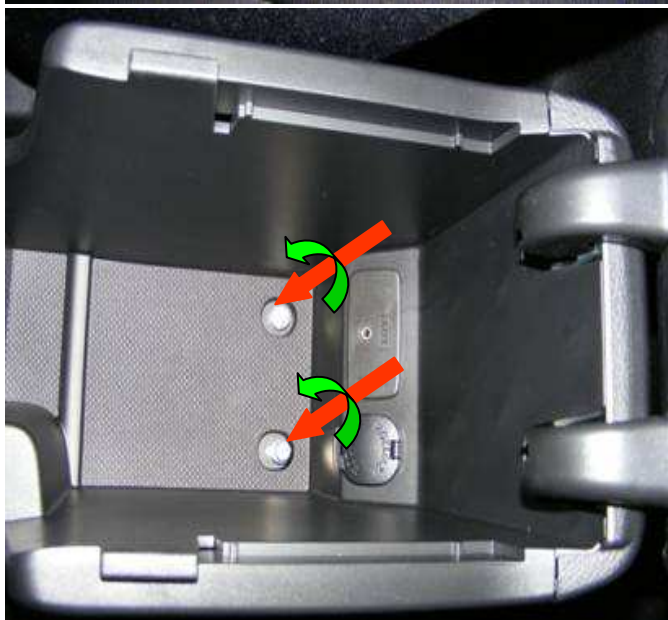
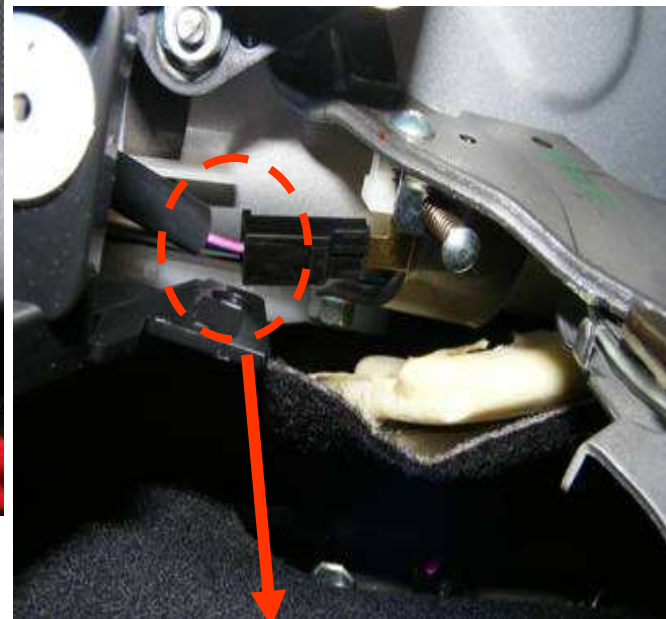

Retirer la console centrale pour pouvoir accéder au contacteur de frein à main.

*Signal sécurité
Fil Mauve/Rouge du contacteur frein à main avec le fil Vert Pioneer
PARKING BRAKE*



Connections du fil d'amplification de l'antenne radio Subaru

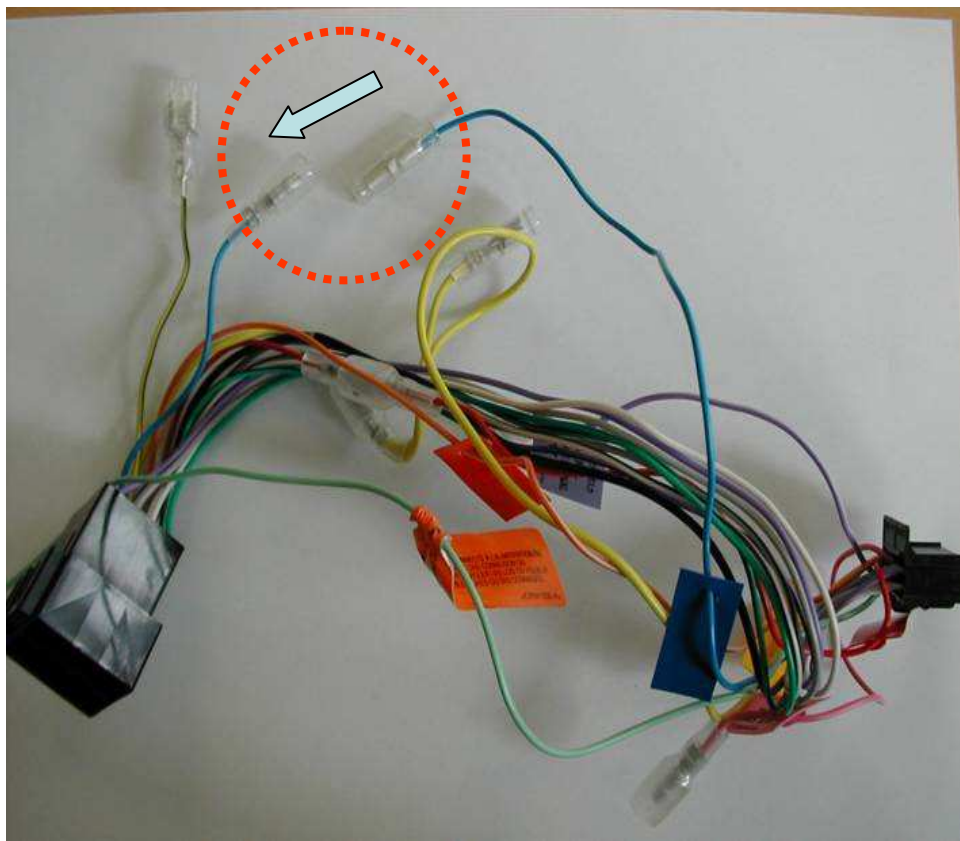

*Connecter les deux fils
bleu ANTENNA
CONTROL Pioneer
ensembles.*



Connections du fil information vitesse



Déposer l'entourage du compteur .

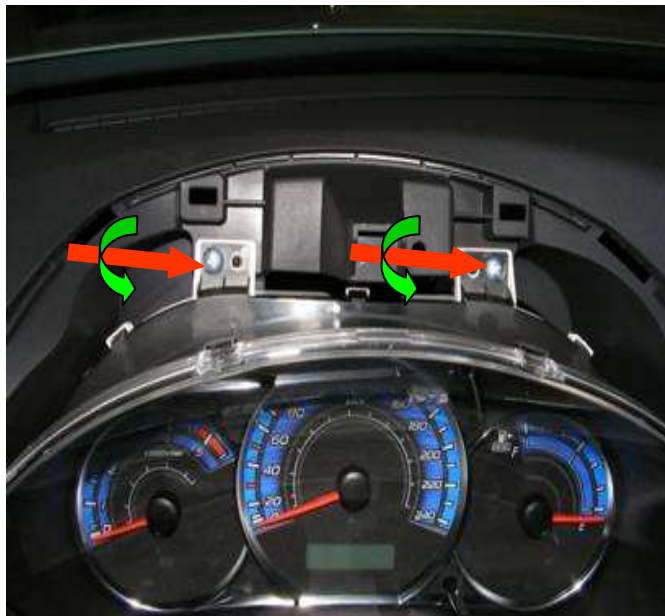

Déposer le compteur en dévissant les deux vis.



Déconnecter le connecteur du compteur

Connections du fil information vitesse



Signal de vitesse epissure, soudure, isolation, du fil Rose Pioneer **CAR SPEED SIGNAL INPUT** sur le connecteur blanc à 40 broches, cavité 31, fil Rose / liseré Vert

Installation du micro kit main libre

Passer le câble du micro dans le compartiment compteur.

Passer le câble du micro sous la garniture du montant avant gauche du par brise.

Fixer le micro à l'aide de sa patte de fixation

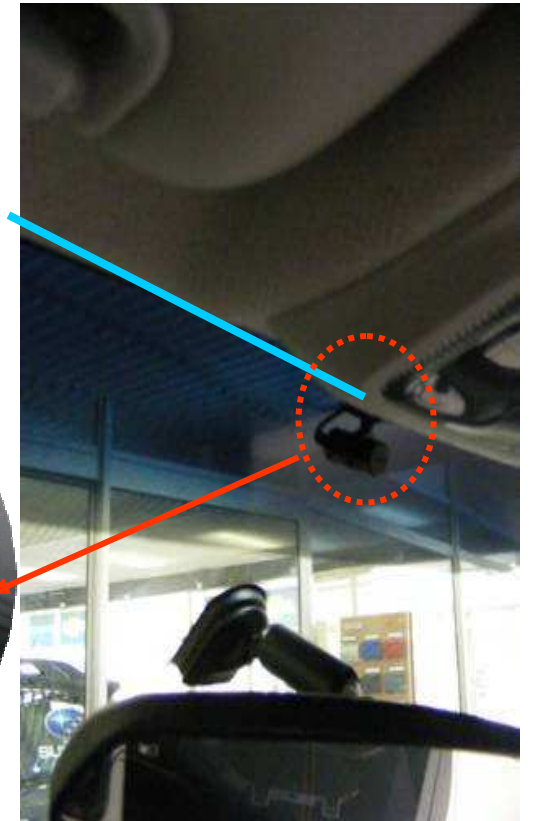

Passage du câble du micro



Pioneer
CIP

Démontage de l'autoradio.

- Retirer le support.

Dévisser les vis (3 mm × 6 mm) pour retirer le support.

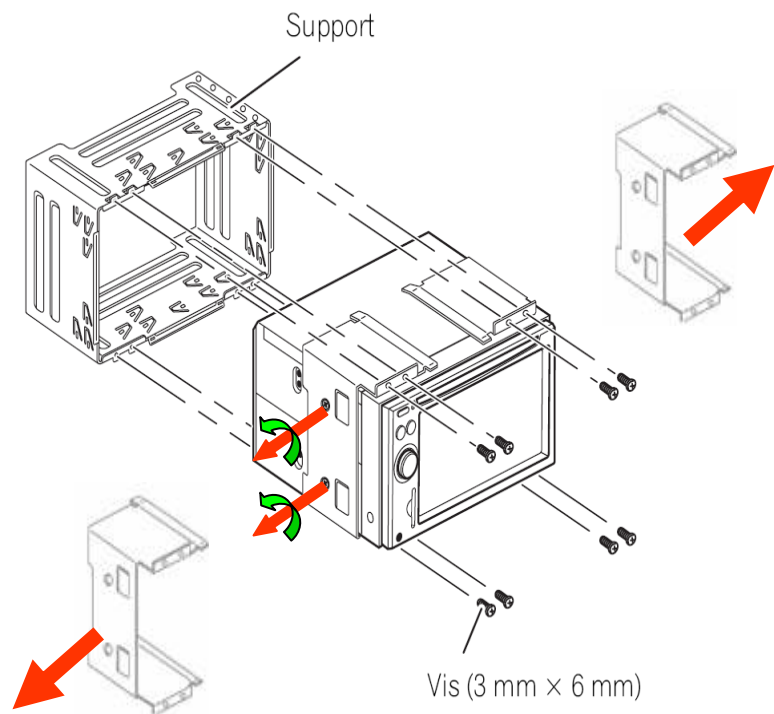

Démontage de l'autoradio.

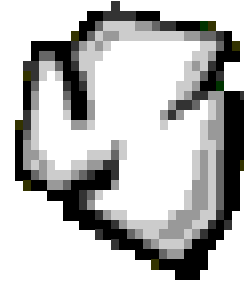
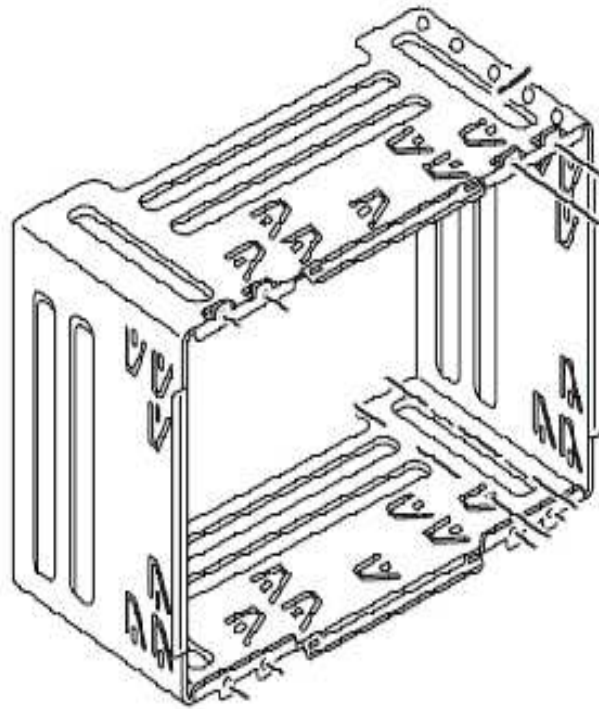
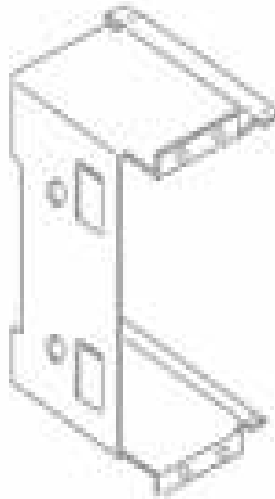
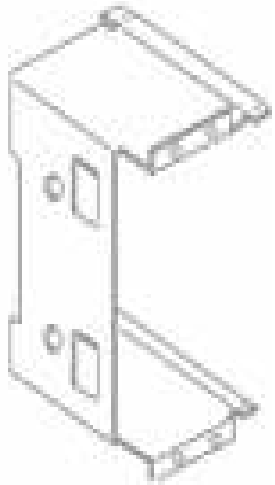

Fixation de l'autoradio

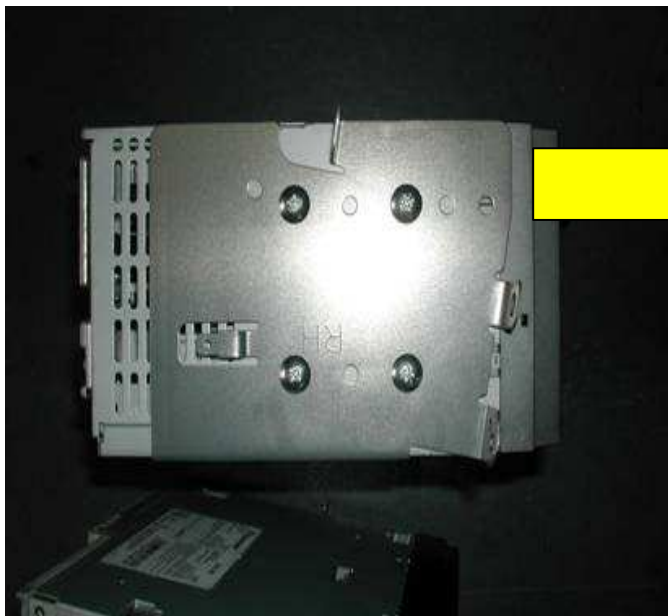

Dépose et récupération des 2 plaques et des 8 vis de l'autoradio d'origine.

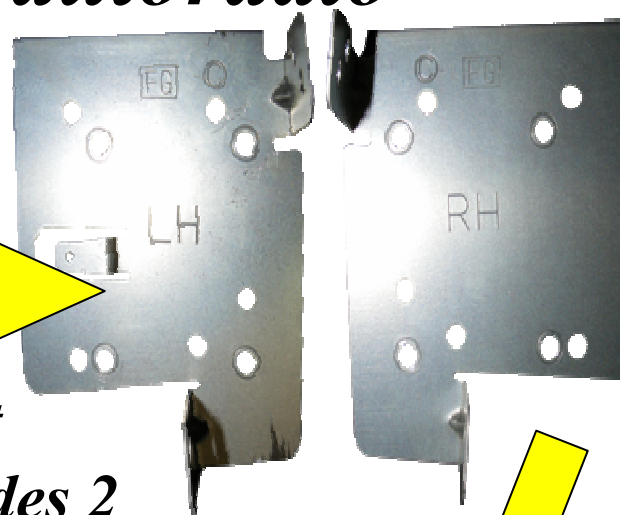

Fixation des 2 plaques droite et gauche sur la navigation Pioneer à l'aide des 8 vis.



Pioneer

Fixation de l'autoradio et remontage des caches

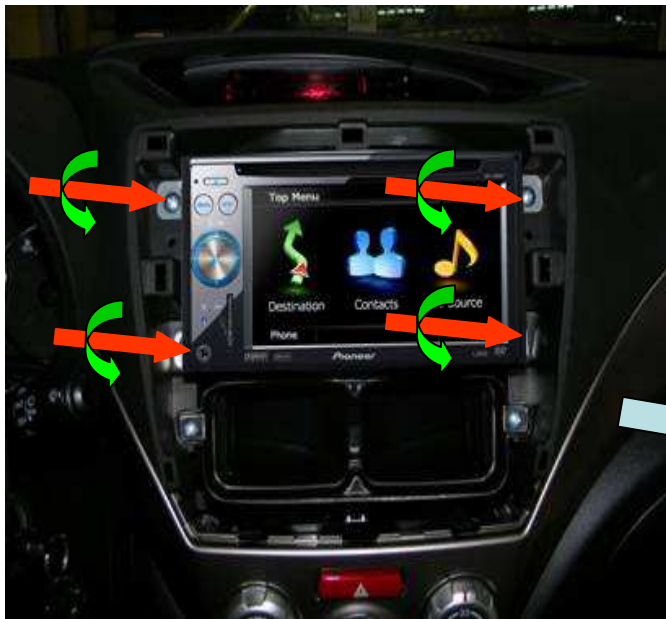

Fixer l'autoradio à l'aide des 4 vis de fixation d'origine.

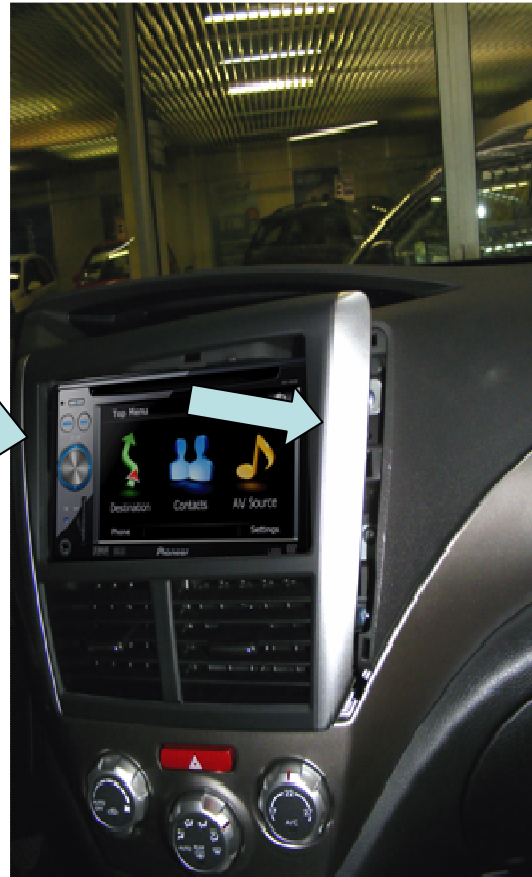

Reposer l'entourage de l'autoradio .



Reclipser l'enjoliveur .

