



...connecting to the aftermarket

CT23FD14

Ford/Mazda Double DIN Fitting Kit



Application:
Ford Ranger 2007 - 2012
Mazda BT-50 2007 - 2012

Not for North American Models

www.connects2.com

Designed and
Engineered
in the UK. 

CT23FD14

Ford/Mazda Double DIN Fitting Kit finished in Silver to match the OEM dashboard.
Not for North American models

Product Contents

1. Double DIN Fascia Panel
2. Fitting Accessories

Prior to installation

Read the manual prior to installation. Technical knowledge is necessary for installation. The place of installation must be free of moisture and away from heat sources. Please ensure you use the correct tools to avoid damage to the vehicle or product.

Connects2 can not be held responsible for the installation of this product.

Technical Support

Connects2 want to provide a fast and suitable resolution should you encounter any technical issues. With this in mind, when contacting Connects2, try to provide as much information as possible. This will speed up the process and help us to help you.

Please use our dedicated online technical support centre: support.connects2.com



Subscribe to our YouTube Channel for installation guides and tips... www.youtube.com/connects2

FITTING GUIDE

1. Disassemble the dash and remove the three (3) climate control knobs and two (2) Phillips screws from behind

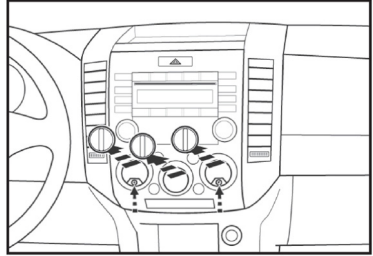

2. Using a panel removal tool, unsnap and remove the radio/climate control panel

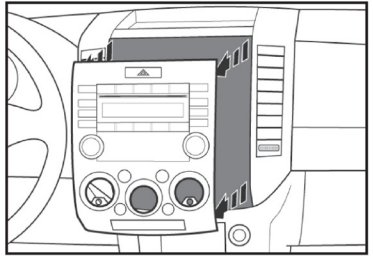

3. Remove the fresh air and circulation stickers from the factory panel and place them in the appropriate locations in the kit

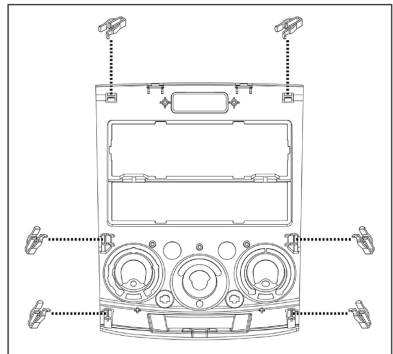

4. Remove the hazard button and AC/defrost buttons from the factory panel, and install them onto the kit

FITTING GUIDE

5. Snap the Double DIN brackets to the inside edge of the Double DIN trim plate

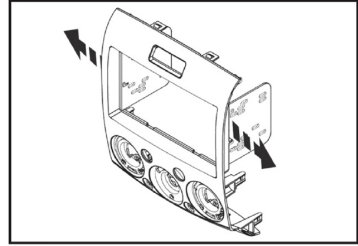

6. Slide the Double DIN head unit into the bracket/radio housing assembly (from behind) and secure the head unit to the assembly using the screws supplied with the radio

7. Snap the Double DIN trim plate into the radio housing

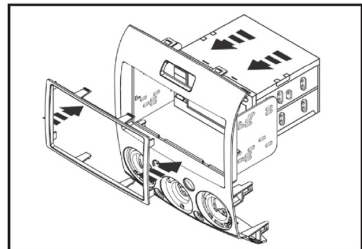

8. Make all connections to the radio and reassemble dashboard in reverse order of disassembly to complete your installation