

SCHÉMA N°8

SCHÉMA STANDARD :
TEMPS 6 SECONDES.

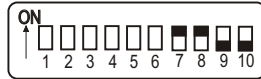

7-8 ON pour centrale 1190

NOTA : Pour 1190 Dip-switch position (Comfort Négatif).

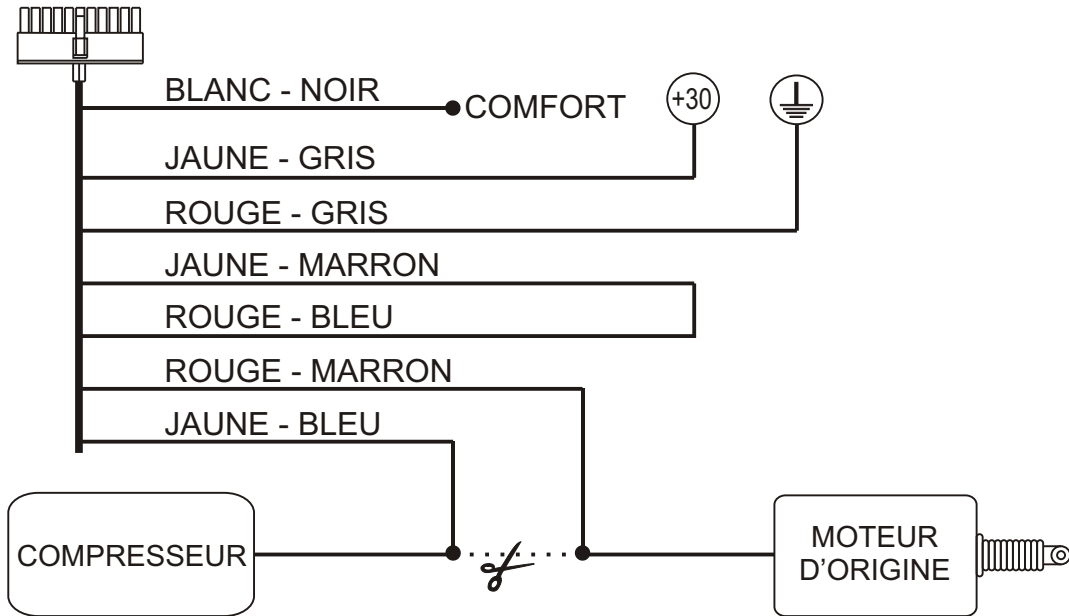

SCHÉMA A 3 FILS :
TEMPS 6 SECONDES.

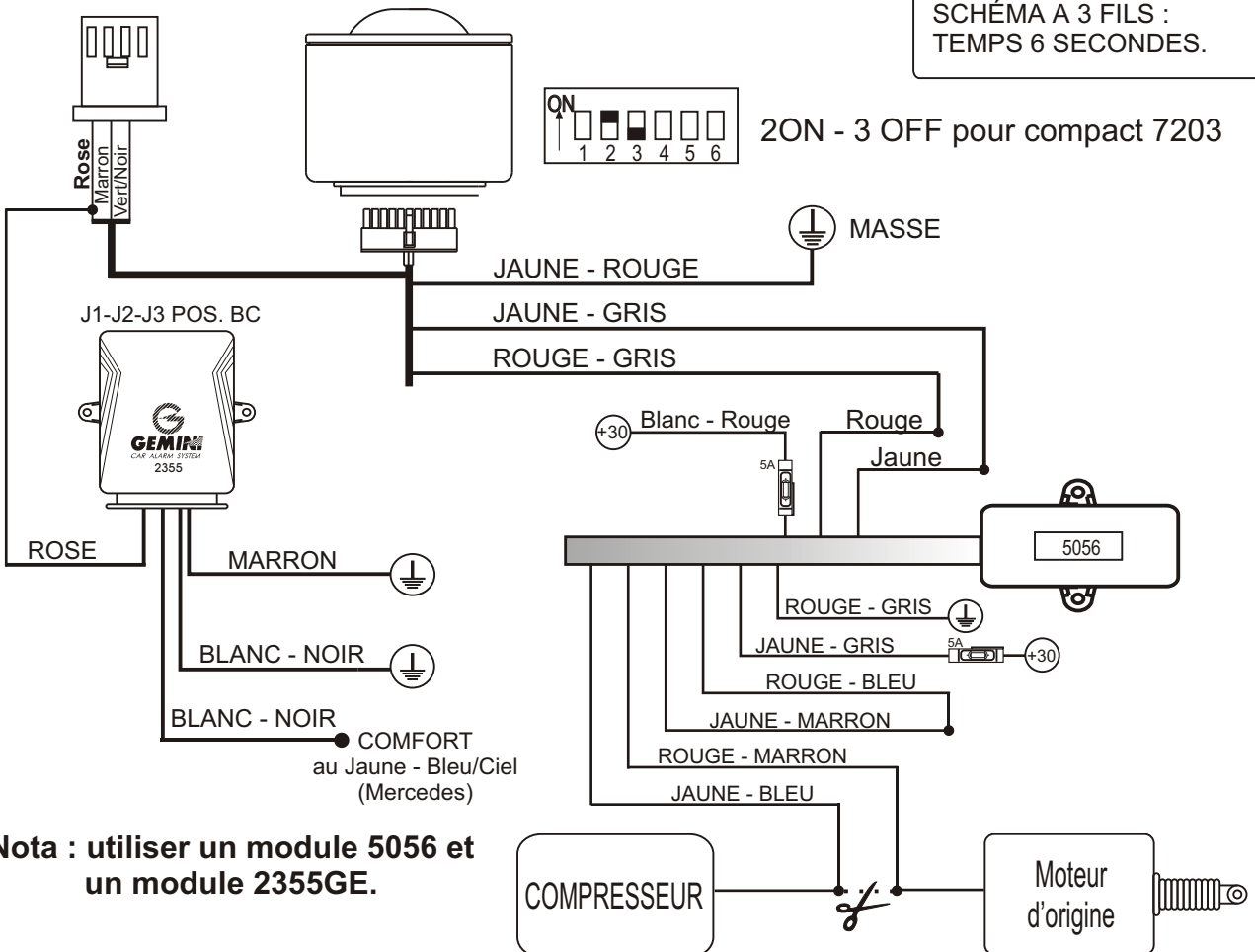

Nota : utiliser un module 5056 et un module 2355GE.